

MICROWAVE OVEN

System Manual & Operation Guide

1. SYSTEM CONFIGURATION

1.1 Description of Controller

The GMS81C2012 and GMS81C2020 are advanced CMOS 8-bit microcontroller with 12K/20K bytes of ROM. These are a powerful microcontroller which provides a highly flexible and cost effective solution to many VFD applications. These provide the following standard features: 12K/20K bytes of ROM, 448 bytes of RAM, 8-bit timer/counter, 8-bit A/D converter, 10-bit High Speed PWM Output, Programmable Buzzer Driving Port, 8-bit Basic Interval Timer, 7-bit Watch dog Timer, Serial Peripheral Interface, on-chip oscillator and clock circuitry. They also come with high voltage I/O pins that can directly drive a VFD (Vacuum Fluorescent Display). In addition, the GMS81C2012 and GMS81C2020 support power saving modes to reduce power consumption.

Device name	ROM Size	RAM Size	OTP	Package
GMS81C2012	12K bytes	448 bytes	-	64SDIP, 64MQFP, 64LQFP
GMS81C2020	20K bytes		GMS87C2020	

1.2 Features of Controller

- 20K/12K bytes ROM(EPROM)
- 448 Bytes of On-Chip Data RAM (Including STACK Area)
- Minimum Instruction Execution time:
 - 1uS at 4MHz (2cycle NOP Instruction)
- One 8-bit Basic Interval Timer
- One 7-bit Watch Dog Timer
- Two 8-bit Timer/Counters
- 10-bit High Speed PWM Output
- One 8-bit Serial Peripheral Interface
- Two External Interrupt Ports
- One Programmable 6-bit Buzzer Driving Port
- 60 I/O Lines
 - 56 Programmable I/O pins (Included 30 high-voltage pins Max. 40V)
 - Three Input Only pins: 1 high-voltage pin
 - One Output Only pin
- Eight Interrupt Sources
 - Two External Sources (INT0, INT1)
 - Two Timer/Counter Sources (Timer0, Timer1)
 - Four Functional Sources (SPI,ADC,WDT,BIT)
- 12-Channel 8-bit On-Chip Analog to Digital Converter
- Oscillator:
 - Crystal
 - Ceramic Resonator
 - External R Oscillator
- Low Power Dissipation Modes
 - STOP mode
 - Wake-up Timer Mode
 - Stand-by Mode
 - Watch Mode
 - Sub-active Mode
- Operating Voltage: 2.7V ~ 5.5V (at 4.5MHz)
- Operating Frequency: 1MHz ~ 4.5MHz
- Sub-clock: 32.768KHz Crystal Oscillator
- Enhanced EMS Improvement Power Fail Processor (Noise Immunity Circuit)

1.3 How The Microwave Oven Works

Microwaves are a form of energy similar to radio and television waves and ordinary daylight. Normally, microwaves spread outwards as they travel through the atmosphere and disappear without effect. Microwave ovens, however, have a magnetron which is designed to make use of the energy in microwaves. Electricity, supplied to the magnetron tube, is used to create microwave energy.

These microwaves enter the cooking area through openings inside the oven. A turntable or tray is located at the bottom of the oven. Microwaves cannot pass through metal walls of the oven, but they can penetrate such materials as glass, porcelain and paper, the materials out of which microwave-safe cooking dishes are constructed.

Microwaves do not heat cookware, though cooking vessels will eventually get hot from the heat generated by the food.

1.4 Features of System

- **Display : 7-Digit, 14-segment Scroll Display**
- **LSI : GMS81C2020**
- **Custom Set:**
 - Sound On/Off, Clock On/Off, Scroll Speed,
 - Lbs/Kg, Demo On/Off
- **Kitchen Timer Function**
 - Concurrent Timer
 - Timer Data Recall Display
- **Auto Weight Defrost : Meat, Poultry, Fish**
 - Lbs Max Weight : 6.0 Lbs
 - Kg Max Weight : 4.0 Kg
- **Time Defrost**
- **EZ ON / Plus 1 Minute Function**
- **More/less Function(+ -10 Sec.)**
- **Turntable On/Off key(12-3/4")**
- **Custom Cook:**
 - Personal Programmable,
 - Auto Touch Keypad
- **Help Function**
- **Fan Control: High/Medium/Low/Off**
- **Cooktop Light Level Control:**
 - High/Low/Off (30 Wattsx2)
- **Cooktop Light Timer**
- **Time-Of-Day Clock**
- **Variable Cook Power: 10 levels**
- **Hold warm**
- **6 Sensor Touch Keypads**
 - Popcorn, Potato, Pizza
 - Sensor Vegetable (3 Category) :
 - Fresh Vegetable
 - Frozen Vegetable
 - Canned Vegetable
 - Sensor Cook (3 Category) :
 - Frozen Entree
 - Casserole
 - Rice
 - Sensor Reheat (3 Category) :
 - Casserole
 - Dinner Plate
 - Soup/Sauce
- **Auto Touch Keypads**
 - Popcorn : 1.75 Oz, 3.0Oz, 3.5Oz
 - Potato : 1, 2, 3, 4EA
 - Beverage : 1,2 Cups
 - Auto Cook (4 Category) :
 - Fresh Vegetable : 1, 2, 3, 4 Cups
 - Frozen vegetable : 1, 2, 3, 4 Cups
 - Rice : 1, 2 Cups
 - Casserole : 1, 2, 3, 4 Cups
 - Auto Reheat (4 Category) :
 - Dinner Plate : 1, 2 Servings
 - Soup/Sauce : 1, 2, 3, 4 Cups
 - Casserole : 1, 2, 3, 4 Cups
 - Roll/Muffin : 1, 2, 3, 4 Servings

2. SYSTEM DIAGRAM

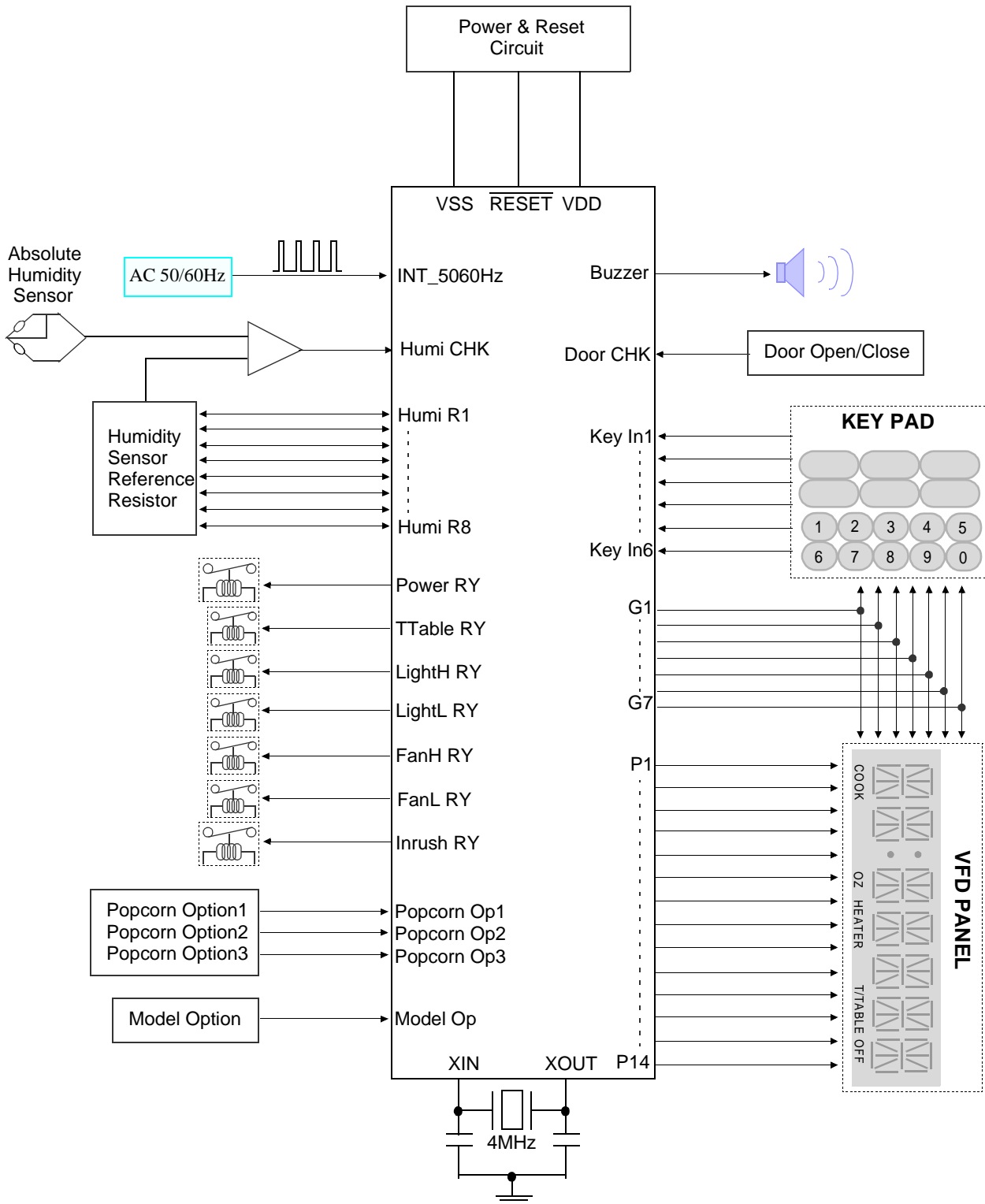

3. KEY MATRIX & OPTION LIST

3.1 Key Matrix

	1	2	3	4	5	6	7
8	Fan Hi/Low/Off	Help	Auto Cook	Popcorn	Time	5	0
9	Light Hi/Low/Off	Custom Select	Auto Reheat	Potato	Auto Defrost	6	1
10	Less	Clock AM/PM	E.Z On	Beverage	Kitchen Timer	7	2
11	Memory	Light Timer	Time Defrost	Pizza	Power Level	8	3
12	T/Table On/Off	Stop Clear	Start	Timer Off	Hold Warm	9	4
13	More	Sensor Pizza	Sensor Potato	Sensor Popcorn	Sensor Vegetable	Sensor Reheat	Sensor Cook

3.2 Model Option

Model NUM.	1	2	3	4	5	6	7	8	9	10
Model Name	Sensor W/Pool 3 Step	DDS Amana 3 Step	T/T Only Amana 3 Step	-	-	-	T/T Only Amana 3 Step	T/T Only W/Pool 3 Step	Sensor Amana 3 Step	-
R106 (High)	-	47K	33K	22K	12K	10K	12K	12K	10K	47K
R107 (Low)	47K	10K	12K	12K	10K	12K	22K	33K	47K	-

3.3 Popcorn Option

Model NUM.	1.75Oz R	3.00Oz R	3.50Oz R	+0	+3	+6	+9	+12	-3	-6	-9	-12	-
High	R100	R102	R104	-	47K	33K	22K	12K	10K	12K	12K	10K	47K
Low	R101	R103	R105	47K	10K	12K	12K	10K	12K	22K	33K	47K	-

4. PIN ASSIGNMENT

Pin Name	In/Out	Signal Name	Function
VDD	I	VDD	Supply voltage
VSS	I	VSS	Circuit ground
RA (V_{disp})	I	V_{disp}	High-voltage input power supply pin
\overline{RESET}	I	RESET	Reset signal input
XIN	I	XIN	4MHz Oscillation input
XOUT	O	XOUT	4Mhz Oscillation output
SXIN(R74)	I	Not Used	Not Used
SXOUT(R75)	O		
R00 (INT0)	I/O (I)	INT 50/60Hz	External interrupt 50/60 Hz
R01 (INT1)	I/O (O)	Main RY	Main Relay Control
R02 (EC0)	I/O (O)	T/Table RY	Turn Table Relay Control
R03 (BUZO)	I/O (O)	Buzzer	Buzzer driving output
R04	I/O (O)	FanH RY	Fan High Relay Control
R05	I/O (O)	FanL RY	Fan Low Relay Control
R06	I/O (O)	LightH RY	Light High Relay Control
R07	I/O (O)	LightL RY	Light Low Relay Control
R10	I/O (O)	InRush RY	Inrush Relay Control
R11 ~ R26	I/O (O)	P1~P14	14 Segments Control
R27 ~ R35	I/O (O)	G1~G7	7 Grid Control
R40 ~ R43	I/O (I)	Key In1 ~ Key In4	Key Inputs
R50 ~ R51	I/O (I)	Key In5 ~ Key In6	
R52	I/O (I)	Door CHK	Door Open/Close Check
R53 ~ R56	I/O (I/O)	Humi R5 ~ Humi R8	Humidity Sensor Reference Resistor
R57	I/O (O)	Not Used	Not Used
R60 ~ R62 (AN0 ~ AN2)	I/O (I)	Popcorn Op1 ~ Op3	Popcorn Option Inputs
R63	I/O (O)	Power RY	Power Relay Control
R64 ~ R67	I/O (I)	Humi R1 ~ Humi R4	Humidity Sensor Reference Resistor
R70 (AN8)	I/O (I)	Model Op	Model Option Input
R71 ~ R72	I/O (O)	Not Used	Not Used
R73(AN11)	I/O (I)	Humi CHK	Humidity Sensor Input
AVDD	I	AVDD	Supply voltage input pin for ADC
AVSS	I	AVSS	Ground level input pin for ADC

5. SYSTEM CONTROL PANEL

5.1 Sensor Model

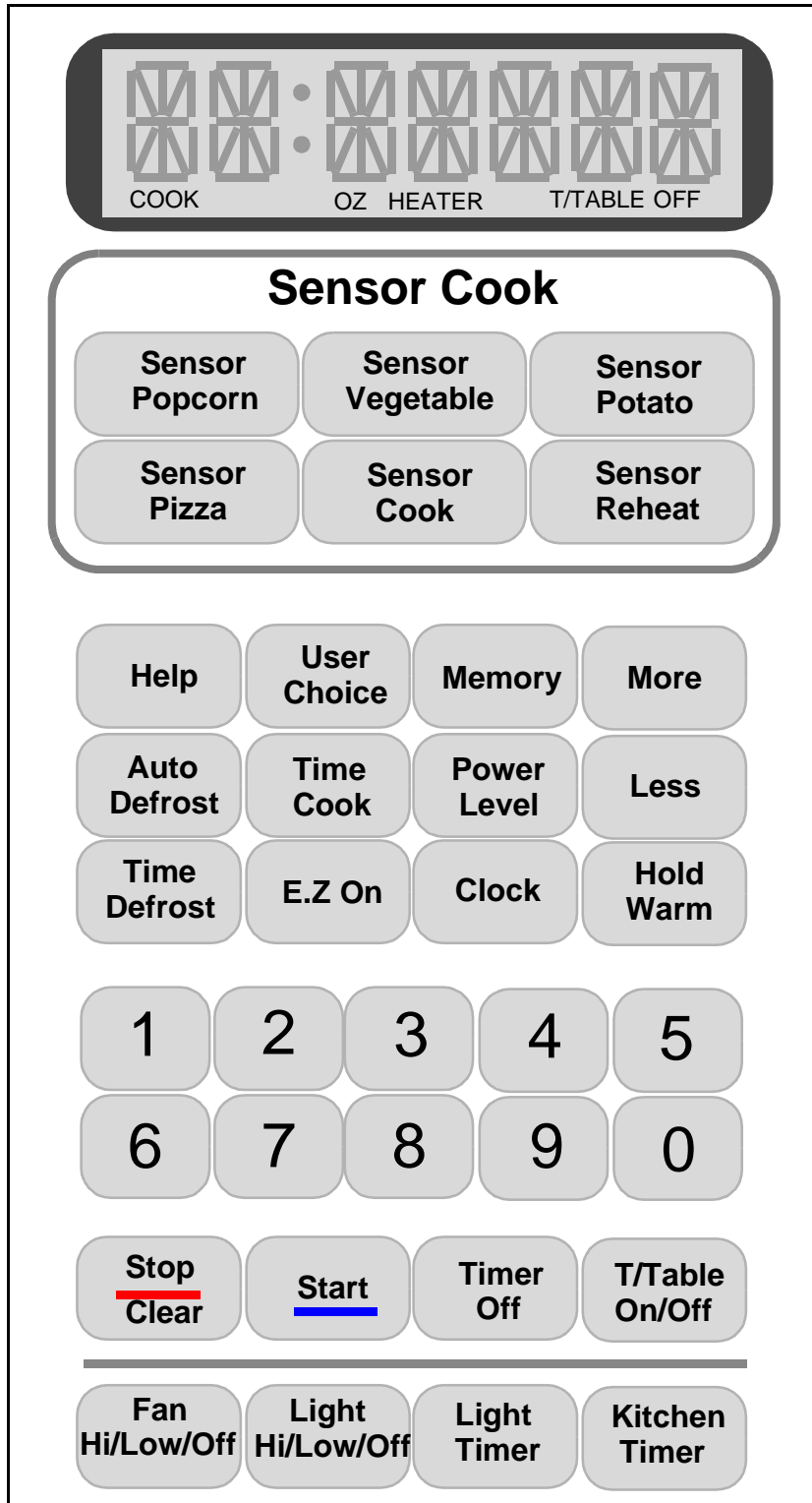

5.2 Non-Sensor Model

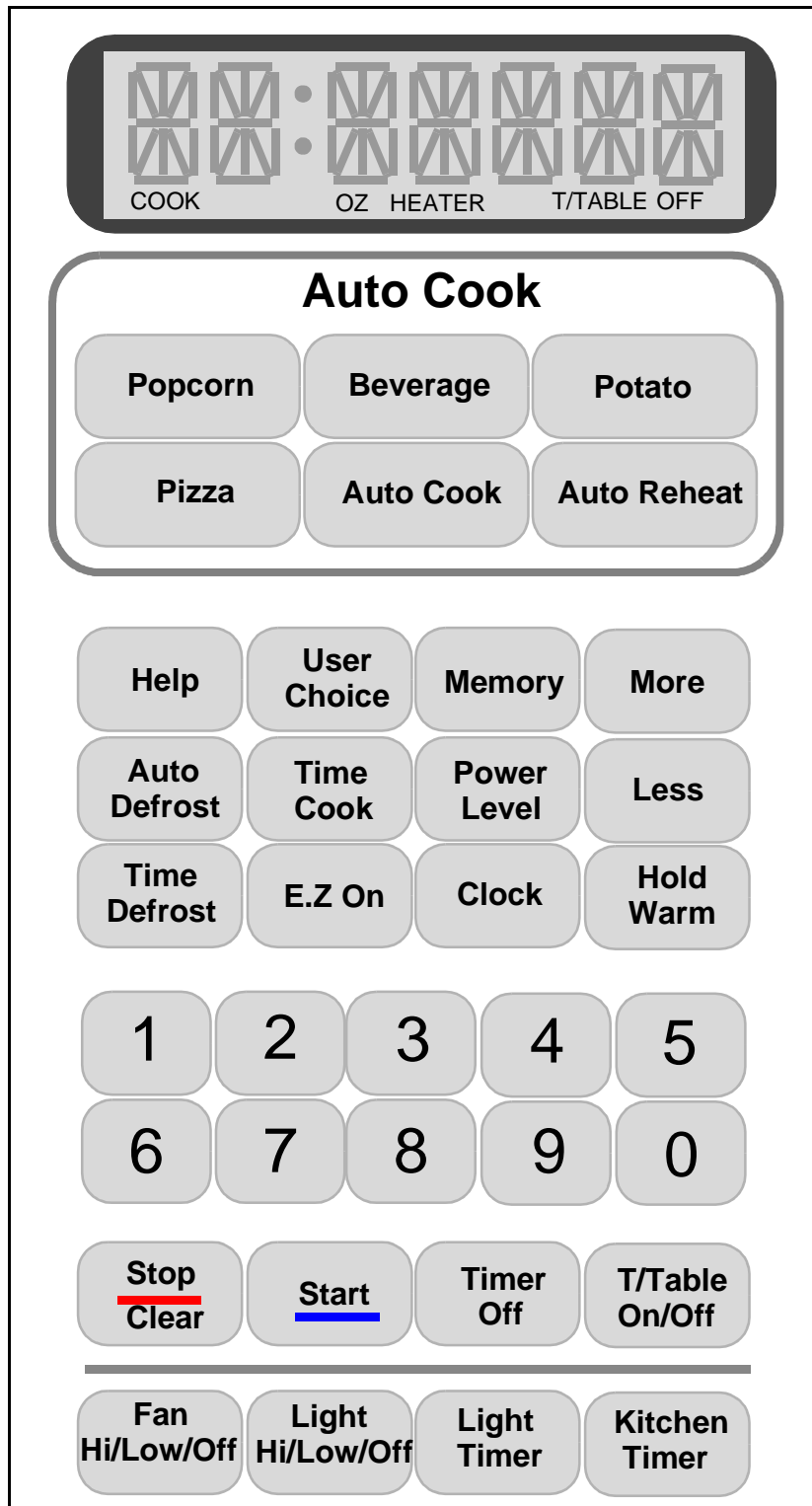

6. CONTROL PANEL INFORMATION

6.1 Display Part

The display includes a clock and indicators to tell you time of day, cooking time settings, and cooking functions selected.

6.2 Sensor Cook

Touch these keys let you cook foods easily.

6.3 Auto Cook

Touch these keys let you cook foods easily.

6.4 Auto Defrost

Ground Meat, Poultry, Fish. Touch on pad to select food type and defrost food by weight.

6.5 More(+)

Touch this pad to add ten seconds of cooking time each time you press it.

6.6 Less(-)

Touch this pad to subtract ten seconds of cooking time each time you press it.

6.7 Ez On

Touch this pad to cook for one minute at 100% power level.

6.8 Number pads

Touch number pads to enter cooking time, power level, quantities, or weights.

6.9 Power Level

Touch this pad to select a cooking power level.

6.10 Hold Warm

Touch this pad to keep hot, cooked foods safely warm in your microwave oven for up to 99 minutes 99 seconds.

6.11 Stop/Clear

Touch this pad to stop the oven or to clear all entries.

6.12 Start

Touch this pad to start a function. If you open the door after oven begins to cook, **Start** again.

6.13 Memory(Custom Cook)

Touch this pad to cook to recall one cooking instruction previously programmed into memory.

6.14 User Choise(Custom Set)

Touch this pad to change the oven's default settings for sound, clock, display, speed, defrost weight, and demo mode operations.

6.15 Help

Touch this pad to learn how to use each oven function.

6.16 Clock(Time Of Day)

Touch this pad to enter the time of day.

6.17 Light Timer

Touch this pad to set the light timer.

6.18 Kitchen Timer

Touch this pad to set the kitchen timer.

6.19 Fan Hi/Low/Off

Touch this pad to turn the fan on or off.

6.20 Light Hi/Lot/Off

Touch this pad to turn on the cooktop/countertop light.

7. SYSTEM OPERATION

This section discusses the concepts behind microwave cooking and introduces you to the basics you need to know to operate this system.

7.1 Clock(Time Of Day)

This oven includes a 24-hour clock.

Example : To set 8:00 AM

1. Touch **Stop/Clear**.
2. Touch **Clock**.
(Press once for AM, twice for PM.)
3. Enter the time by using the number key pad.
4. Touch **Start**.

7.2 Kitchen Timer

You can use this system as a timer. Use the **Timer** for timing up 99 minutes, 99 seconds.

Example : To count 3 minutes

1. Touch **Stop/Clear**.
2. Touch **Kitchen Timer**.
3. Enter the time by using the number key pad.
4. Touch **Start**.
When the time is over, you will hear on long beep and **END** will display.

7.3 Light Timer

You can set the Light to turn on and off automatically at any time you want. The light comes on at the same time every day until reset.

Example : Turn on 2:00 AM, turn off 7:00 AM

1. Touch **Stop/Clear**.
2. Touch **Light Timer**.
(Press once for AM, twice for PM.)
3. Enter the time you want the Light to turn on.
4. Touch **Light Timer** again.
(Press once for AM, twice for PM.)
5. Enter the time you want the Light to turn off.
6. Touch **Start**.

Example : To Cancel the Light Timer

1. Touch **Light Timer**.
2. Touch **Stop/Clear**.

7.4 Fan Hi/Low/Off

The **FAN** moves steam and other vapors from the surface cooking. Touch **FAN** once for High fan speed, twice for Low fan speed, or three times to turn the fan off.

7.5 Child Lock

You may lock the control panel to prevent the microwave from being accidentally started or used by children.

Example : To set the Child Lock

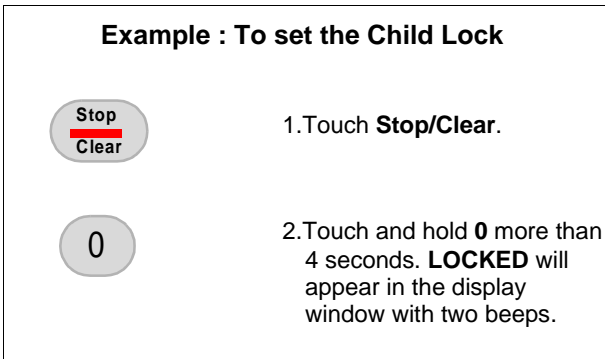

1. Touch **Stop/Clear**.

2. Touch and hold **0** more than 4 seconds. **LOCKED** will appear in the display window with two beeps.

Example : To cancel the Child Lock

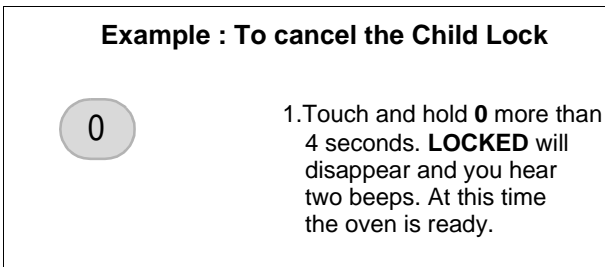

1. Touch and hold **0** more than 4 seconds. **LOCKED** will disappear and you hear two beeps. At this time the oven is ready.

7.6 Light Hi/Low/Off

Touch **Light** once for bright light, twice for night light, or three times to turn the light off.

7.7 User Choice(Custom Set)

You can change the default values for beep sound, clock, display speed, defrost weight, and demo mode operation. See following chart for more information.

NUM	Function	NUM	Result
1	Beep On/Off Control	1	Sound On
		2	Sound Off
2	Clock Display Control	1	Clock On
		2	Clock Off
3	Display	1	Slow Speed
		2	Normal Speed
		3	Fast Speed

NUM	Function	NUM	Result
4	Defrost Weight Mode Select	1	Lbs
		2	Kg
5	Demo Mode Select	1	Demo On
		2	Demo Off

Example : To change defrost weight mode

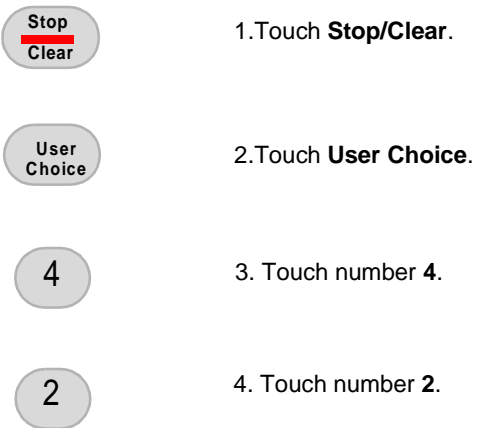

1. Touch **Stop/Clear**.

2. Touch **User Choice**.

3. Touch number **4**.

4. Touch number **2**.

7.8 Help

This **Help** pad display feature information and helpful hints. Press **Help**, then select a key pad.

Example : To learn about Popcorn

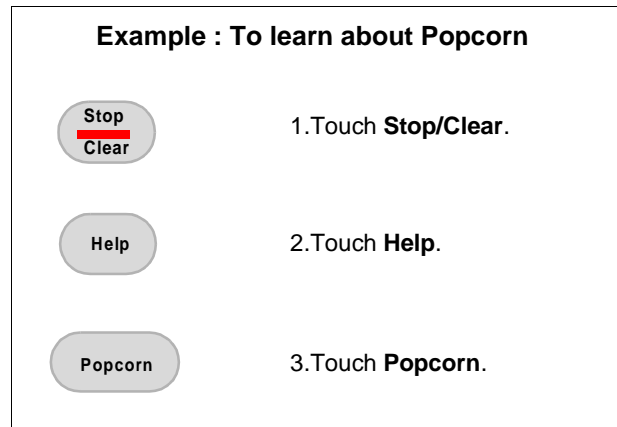

1. Touch **Stop/Clear**.





2. Touch **Help**.

3. Touch **Popcorn**.



7.9 Memory(Custom Cook)

Memory lets you recall one cooking instruction previously placed in memory and begin cooking quickly.

Example : To Memorize for 2 minutes

	1.Touch Stop/Clear .
	2.Touch Memory .
	3. Enter the cook time.
	4. Touch Start .



Example : To recall the Memory

	1.Touch Stop/Clear .
	2.Touch Memory .
	3.Touch Start . When the cook time is over, you will hear three beeps and END will display.

7.10 Ez On

Ez On lets you cook or reheat food for one minute at 100% Power. You can also use it to extend cooking time in multiples of one minute, up to 99 minutes 59 seconds.



Example : To cook for 2 minute

	1.Touch Stop/Clear .
	2.Touch Ez On twice. (Press once for AM, twice for PM.)

7.11 Hold Warm

You can safely keep hot, cooked food warm in your microwave oven for up to 99 minutes 99 seconds. You can use **Hold Warm** by itself or to follow a cooking cycle automatically.



Example : To use the hold warm

	1.Touch Stop/Clear .
	2.Touch Hold Warm . (Press once for AM, twice for PM.)
	3. Touch Start .

7.12 More(+) / Less(-)

By using the **More(+)** or **Less(-)** keys, all of the **Auto Touch**, **Time Cook** program and etc. can be adjusted to cook food for a longer or shorter time. Pressing **More(+)** will add 10 seconds of the cooking time each time you press it. Pressing **Less(-)** will subtract 10 seconds of cooking time each time you press it.

Example : To adjust the 1.75 oz. Popcorn cooking time for a longer time

	1.Touch Stop/Clear .
	2.Touch Popcorn one time. (Press once for AM, twice for PM.)
	3. Touch More .

7.13 Cooking At Lower Power Levels

High Power cooking does not always give you the best results with foods that need slower cooking, such as roasts or custards. Your oven has 9 power settings in addition to High.

Example : To cook food for 7 minutes 30 seconds at 70% power.

1. Touch **Stop/Clear**.
2. Enter the cook time.
3. Touch **Power Level**.
4. Enter the power level.
5. Touch **Start**.
When the cook time is over, you will hear three beeps and **END** will display.

7.14 Cooking At High Cook Power

Example : To cook food for 8 minutes 30 seconds.

1. Touch **Stop/Clear**.
2. Enter the cook time.
3. Touch **Start**.
When the cook time is over, you will hear three beeps and **END** will display.

7.15 Auto Defrost

This microwave oven is preset with three defrost sequences. Using **Auto Defrost** is the best way to defrost frozen foods. The Defrost Sequence Table below provides some basic guidelines for using the three defrost sequences.

Example : To defrost 1.2Lbs. of beef

1. Touch **Stop/Clear**.
2. Touch **Auto Defrost**.
3. Choose food category.

Category	Num Pad
Meat	1
Poultry	2
Fish	3
4. Enter the weight.
5. Touch **Start**.
6. After 1/3 of defrost time is over, the display will prompt you to turn food over. Open door, turn food over, and shield and warm portions.
7. Close the door and restart.
8. After 2/3 of the defrost time is over, the display will prompt you to turn food over. Repeat steps 6 and 7. When the defrost time is over, you will hear three beeps and **END** will display.

7.16 Auto Cook

This system's menu has been preprogrammed to cook food automatically. Tell the this system what you want. Then let you microwave oven cook your selections.

**Example : To cook Popcorn,
simply follow the step below**



1. Touch **Stop/Clear**.



2. Touch **Popcorn**.
one time for 1.75 oz.
two times for 3.0 oz.
three times for 3.5 oz.

The oven begins the cooking you selected without the need to touch **Start**. Be sure to close the door before selecting categories.

8. COOK CHART

8.1 Auto Cook Chart

Key	NUM Key	Category	NUM Key	Q'nty
Popcorn	-	-	1	1.75 Oz.
	-	-	2	3.0 Oz.
	-	-	3	3.5 Oz.
Potato	-	-	1	1 Potato
	-	-	2	2 Potatoes
	-	-	3	3 Potatoes
	-	-	4	4 Potatoes
Beverage	-	-	1	1 Cup
	-	-	2	2 Cups
Pizza	-	-	1	1 Slice
	-	-	2	2 Slices
	-	-	3	3 Slices
Frozen Entree	-	-	1	10 Oz.
	-	-	2	20 Oz.
Auto Cook	1	Fresh Vegetable	1	1 Cup
			2	2 Cups
			3	3 Cups
			4	4 Cups
	2	Frozen Vegetable	1	1 Cup
			2	2 Cups
			3	3 Cups
			4	4 Cups
	3	Rice	1	1 Cup
			2	2 Cups
	4	Casserole	1	1 Cup
			2	2 Cups
			3	3 Cups
			4	4 Cups

Key	NUM Key	Category	NUM Key	Q'nty
Auto Reheat	1	Dinner Plate	1	1 Serving
			2	2 Servings
	2	Soup/ Sauce	1	1 Cup
			2	2 Cups
			3	3 Cups
			4	4 Cups
	3	Casserole	1	1 Cup
			2	2 Cups
Auto Reheat	3	Casserole	3	3 Cups
			4	4 Cups
	4	Roll/Muffin	1	1 Piece
			2	2 Pieces
			3	3 Pieces
			4	4 Pieces

8.2 Sensor Cook Chart

Key	NUM Key	Category
Sensor Popcorn	-	-
Sensor Potato	-	-
Sensor Pizza	-	-
Sensor Vegetable	1	Fresh Vegetable
	2	Frozen Vegetable
	3	Canned Vegetable
Sensor Cook	1	Frozen Entree
	2	Casserole
	3	Rice
Sensor Reheat	1	Dinner Plate
	2	Soup/Sauce
	3	Casserole

8.3 Cooking Guide For Lower Power Levels

The nine power levels in addition to High Allow you to choose the best power level for the food you are cooking. Below are listed all the power levels, examples of foods best cooked at each level, and the amount of microwave power you are using.

Power Level	Microwave Output	Duty (Sec)
10 (High)	100%	22/22
9	90%	20/22
8	80%	18/20
7	70%	16/22
6	60%	14/22
5	50%	12/20
4	40%	10/22
3	30%	8/22
2	20%	6/22
1	10%	4/22
0	-	-

8.4 Beeps Chart.

Status	Beep	Remarks
Key Touch	Short Beep 1 Time	Short Beep : 100mS On / 900mS Off Long Beep : 500mS On / 500mS Off Shorter Beep : 100mS On / 100mS Off
End Cook	Long Beep 4 Times	
End Timer	Long Beep 7 Times	
Child Lock	Shorter Beep 2 Times	
End Reminder	Long Beep 3 Times	
Defrost Turn Over	Short Beep 3 Time	
Stage Change	Short Beep 2 Time	

9. Software Algorithm

9.1 “Auto Cook” Cook Time

Model		DDS Model				T/T Only Model				Serving Unit	Power Level
Cat'y NUM	Category	Serving				Serving					
		Cook Time				Cook Time					
1	Fresh Vegetable	1	2	3	4	1	2	3	4	Cup	100%
		2:30	3:40	5:00	6:00	2:30	3:50	4:50	6:00		
2	Frozen Vegetable	1	2	3	4	1	2	3	4	Cup	100%
		2:30	4:20	6:00	8:00	2:40	4:30	6:10	8:30		
3	Rice	1		2		1		2		Cup	S1=100% S2=50%
		6:00(S1)+16:00		9:00(S1)+18:00		4:50(S1)+16:00		8:30(S1)+18:00			
4	Casserole	1	2	3	4	1	2	3	4	Cup	70%
		3:00	5:50	7:40	10:00	3:10	5:50	7:50	10:10		

9.2 “Auto Reheat” Cook Time

Model		DDS Model				T/T Only Model				Serving Unit	Power Level
Cat'y NUM	Category	Serving				Serving					
		Cook Time				Cook Time					
1	Dinner Plate	1	2	P/L : 100%		1	2	P/L : 70%		Slice	
		4:00	5:40			2:30	3:50				
2	Soup/ Sauce	1	2	3	4	1	2	3	4	Cup	100%
		1:50	3:20	4:50	6:20	2:00	3:40	5:00	6:40		
3	Casserole	1	2	3	4	1	2	3	4	Cup	70%
		2:30	5:00	6:40	9:00	3:00	5:40	7:10	9:20		
4	Roll/ Muffin	1	2	3	4	1	2	3	4	Piece	100%
		:12	:18	:24	:30	:14	:20	:30	:40		

9.3 Inrush Relay Control

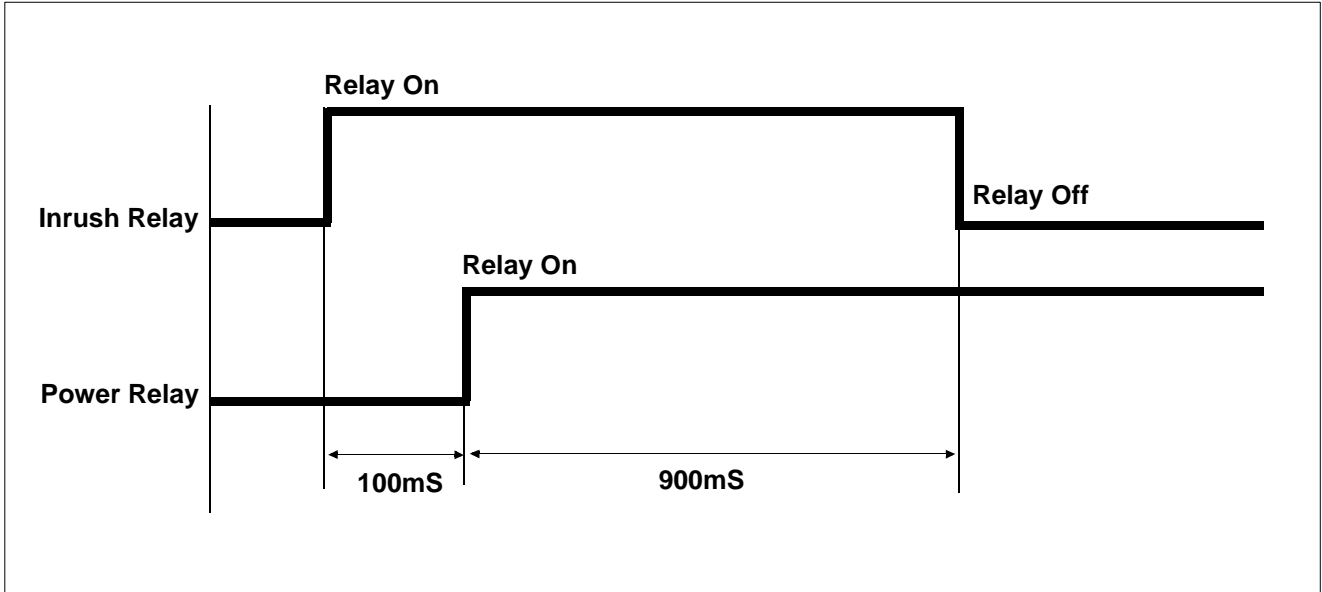

9.4 Sensor Algorithm

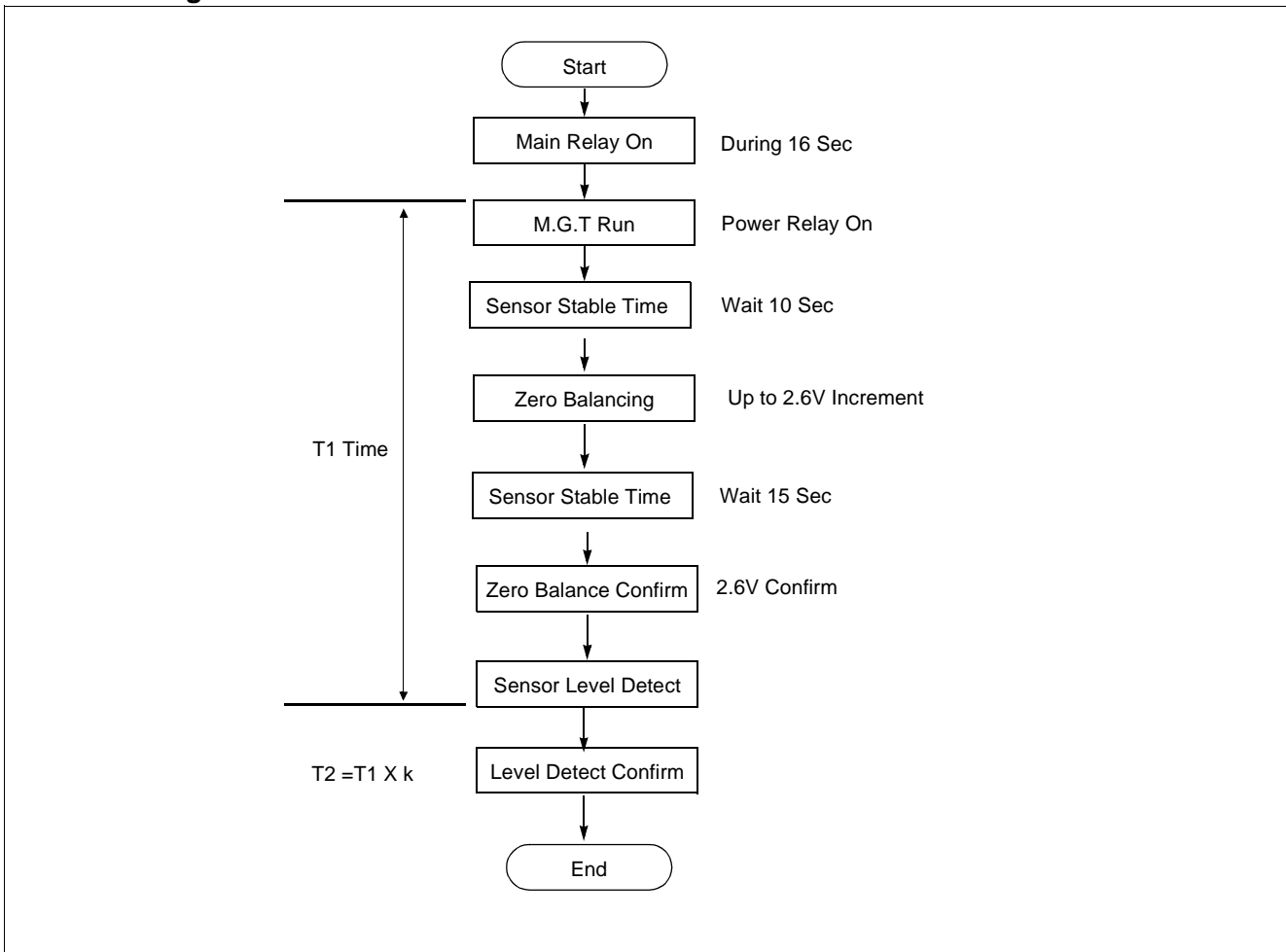

9.5 “Sensor Cook” Cook Data

Category NUM	Category	H (Target Value)	K-Value	T1 Max Time	T1 P/L	T2 P/L
1	Frozen Entree	2.3V	2.0	300"	100%	80%
2	Casserole	2.2V	0.5	400"	100%	100%
3	Rice	2.1V	1020"	780"	100%	40%

9.6 “Sensor Reheat” Cook Data

Category NUM	Category	H (Target Value)	K-Value	T1 Max Time	T1 P/L	T2 P/L
1	Casserole	2.3V	1.0	300"	100%	50%
2	Dinner Plate	2.2V	0.7	247"	100%	100%
3	Soup/Sauce	2.3V	2.0	300"	100%	50%

9.7 “Sensor Vegetable” Cook Data

Category NUM	Category	H (Target Value)	K-Value	T1 Max Time	T1 P/L	T2 P/L
1	Fresh Vegetable	2.2V	0.4	643"	100%	50%
2	Frozen Vegetable	2.4V	0.0	900"	100%	-
3	Canned Vegetable	2.3V	0.0	480"	100%	-

9.8 “Sensor Popcorn, Potato, Pizza” Cook Data

Category NUM	Category	H (Target Value)	K-Value	T1 Max Time	T1 P/L	T2 P/L
1	Popcorn	2.3V	T1<100, 20" T1>100, 30"	150"	100%	100%
2	Potato	2.1V	2.0	450"	100%	100%
3	Pizza	2.2V	1.0	150"	100%	100%

10. VFD INFORMATION

10.1 VFD Characteristics

Vacuum Fluorescent Display(VFD) is a specialized variation of triode. Electrons emitted from the cathode (filament) are accelerated by a grid and collide against the phosphor- coating on the surface of an anode, producing luminescence.

VFDs have the following advantages in comparison with other display devices.

1. Self-luminous device.
2. Excellent visual recognition by means of a clear display with high brightness.
3. Operation at low voltage with low power consumption.
4. High reliability and long service life.
5. Color variety ranging from red to blue; additional colors achieved by using filters.
6. Wide viewing angle.
7. Quick response time.

10.2 Outer Dimension.

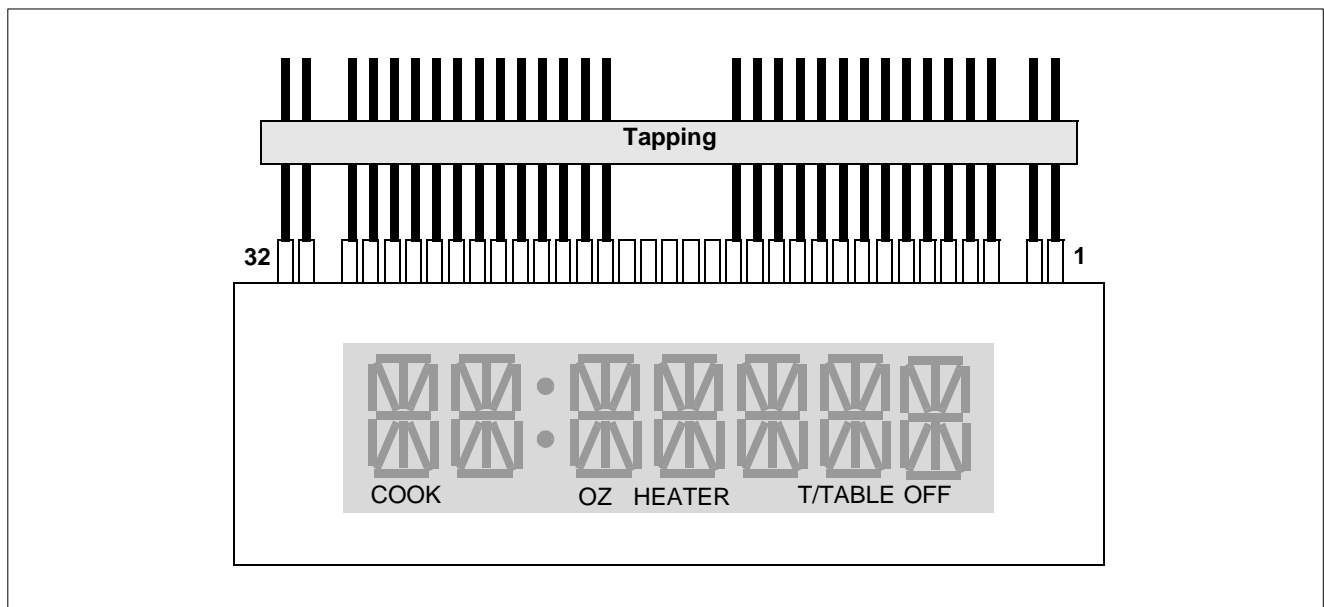

10.3 Pin Assignment

Pin Num.	1	2	3	4	5	6	7	8
Pin Connection	F	F	NP	1G	2G	3G	4G	5G
Pin Num.	9	10	11	12	13	14	15	16
Pin Connection	6G	7G	P14	P13	P12	P11	NX	NX
Pin Num.	17	18	19	20	21	22	23	24
Pin Connection	NX	NX	NX	P10	P9	P8	P7	P6
Pin Num.	25	26	27	28	29	30	31	32
Pin Connection	P5	P4	P3	P2	P1	NP	F	F

10.4 Grid Assignment

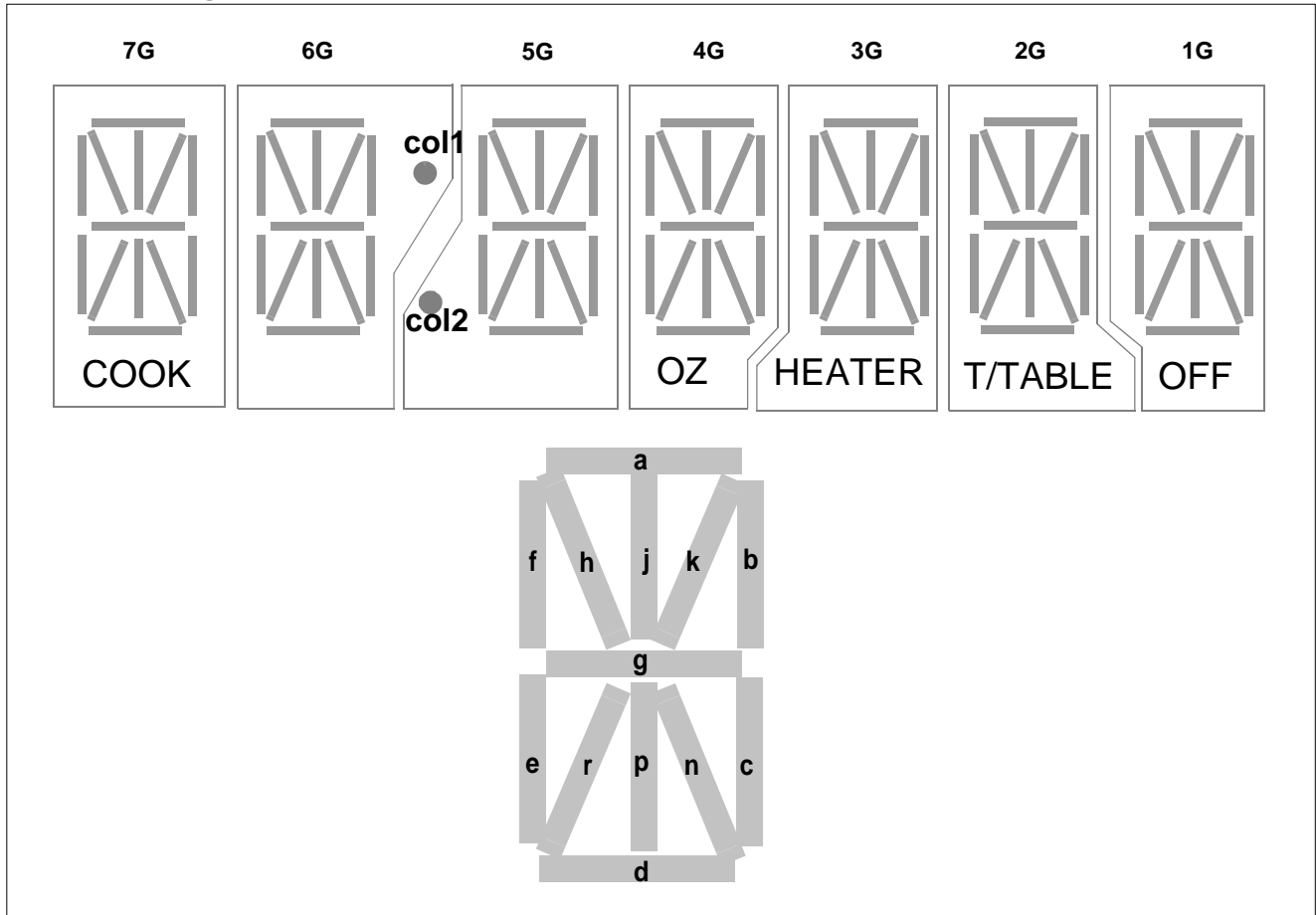

10.5 Anode Connection

	7G	6G	5G	4G	3G	2G	1G
P1	a	a	a	a	a	a	a
P2	b	b	b	b	b	b	b
P3	c	c	c	c	c	c	c
P4	d	d	d	d	d	d	d
P5	e	e	e	e	e	e	e
P6	f	f	f	f	f	f	f
P7	g	g	g	g	g	g	g
P8	h	h	h	h	h	h	h
P9	j	j	j	j	j	j	j
P10	k	k	k	k	k	k	k
P11	n	n	n	n	n	n	n
P12	p	p	p	p	p	p	p
P13	r	r	r	r	r	r	r
P14	COOK	col1	col2	OZ	HEATER	T/TABLE	OFF

10.6 VFD Basic Structure

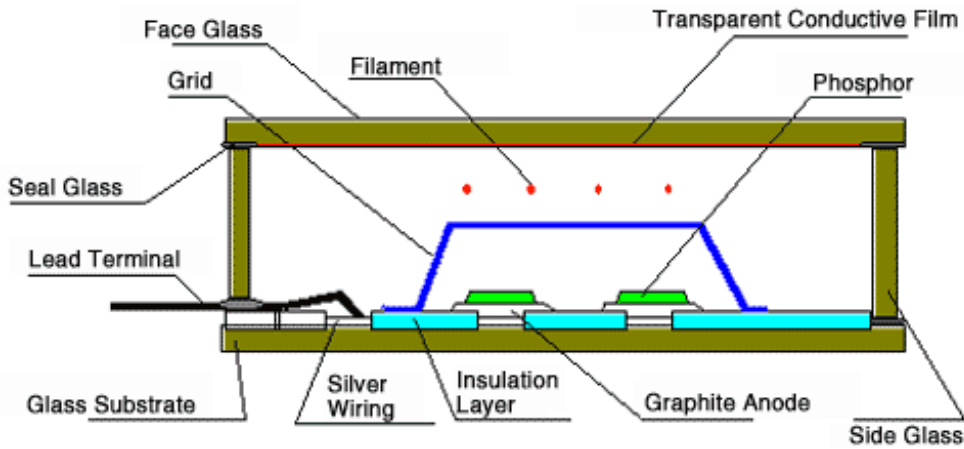

• Glass substrate

The glass substrate is one of the most integral components of a VFD. The electrodes and other key components are formed onto it. The wiring, insulating layer and anode are built up on the glass plate by means of a repeated thick-film printing and baking.

• Filament (Cathode)

The filament is a fine tungsten wire coated with barium oxide. During operation, the cathode emits thermal electrons after heating up the filament.

• Grid

The grid is made of a thin film of stainless steel with a formed tortoise shell or lattice shape.

• Phosphor (Anode)

Phosphor for VFD provides a useful level of practical luminance by means of emitted electrons from the cathode.

• Face glass

It may be produced either by forming a glass plate by hot-working or by assembling a combination of short glass plates, face glass. Face glass maintains the vacuum and a cathode potential to act as a shield to external electrical fields.

• Lead terminals

Lead terminals apply filament voltage, anode and grid voltages. Alternative display types contain lead terminals which lead directly from within the tube.

10.7 VFD Operation Principle

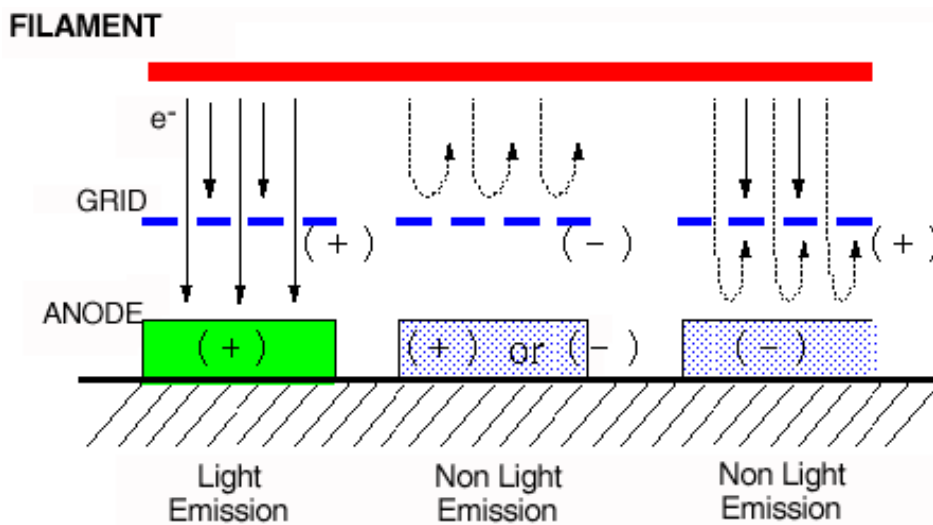

10.8 Filament Driving

- Negative AC

Ebc:23Vpp
 Ef:4.4Vac
 EK:5.0

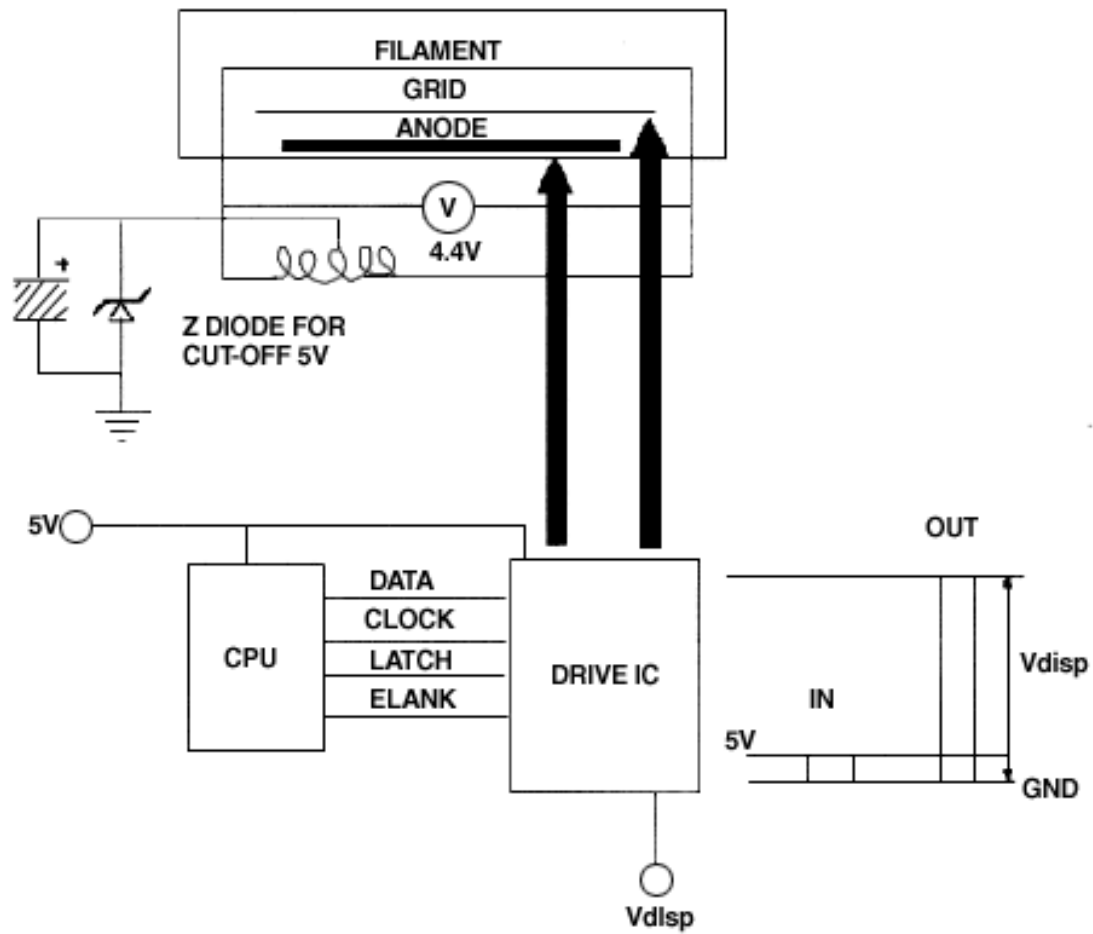
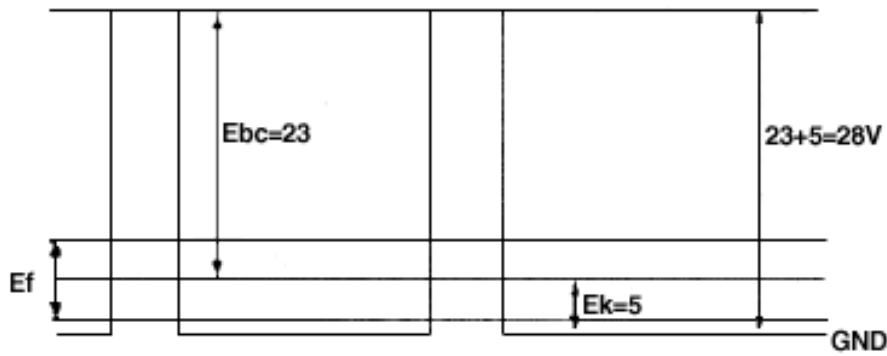

• Positive AC

Ebs : 23Vpp
 Ef : 4.4Vdc
 Ek : 2.0

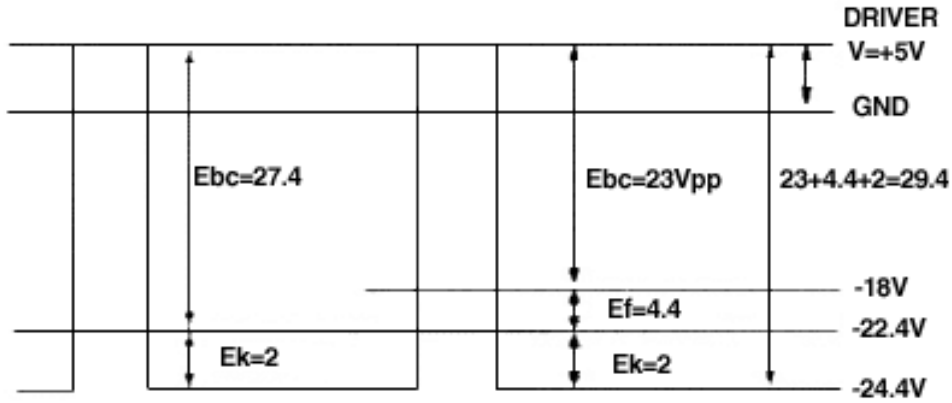

F(-) SIDE

F(+) SIDE

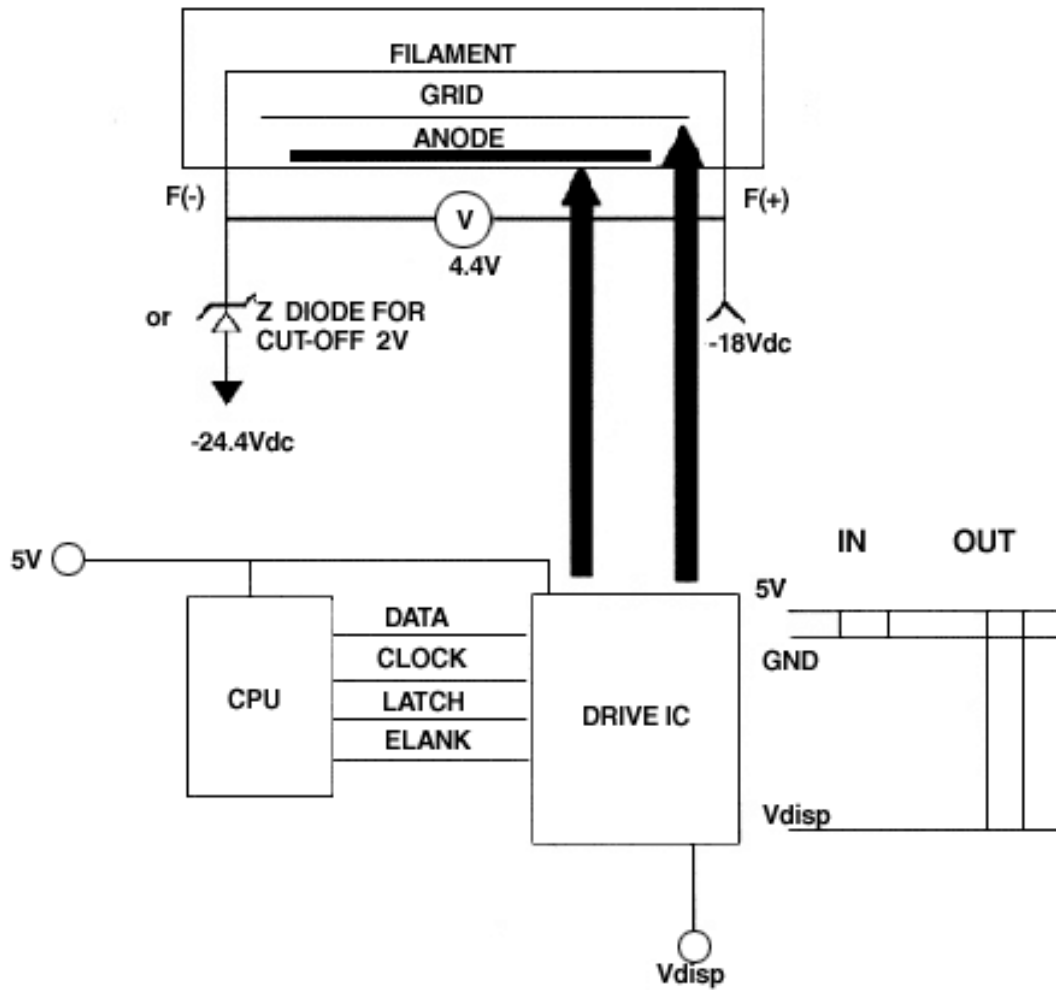

• Negative DC

Ebc:23Vpp
 Ef:4.4Vdc
 Ek:2.0

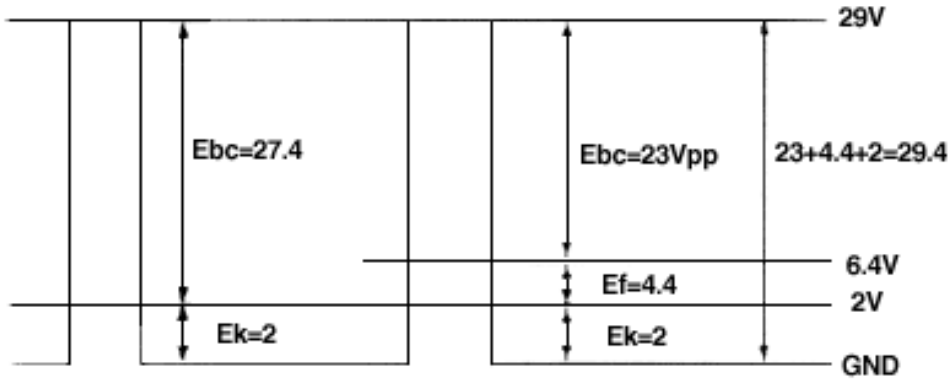

F(-) SIDE

F(+) SIDE

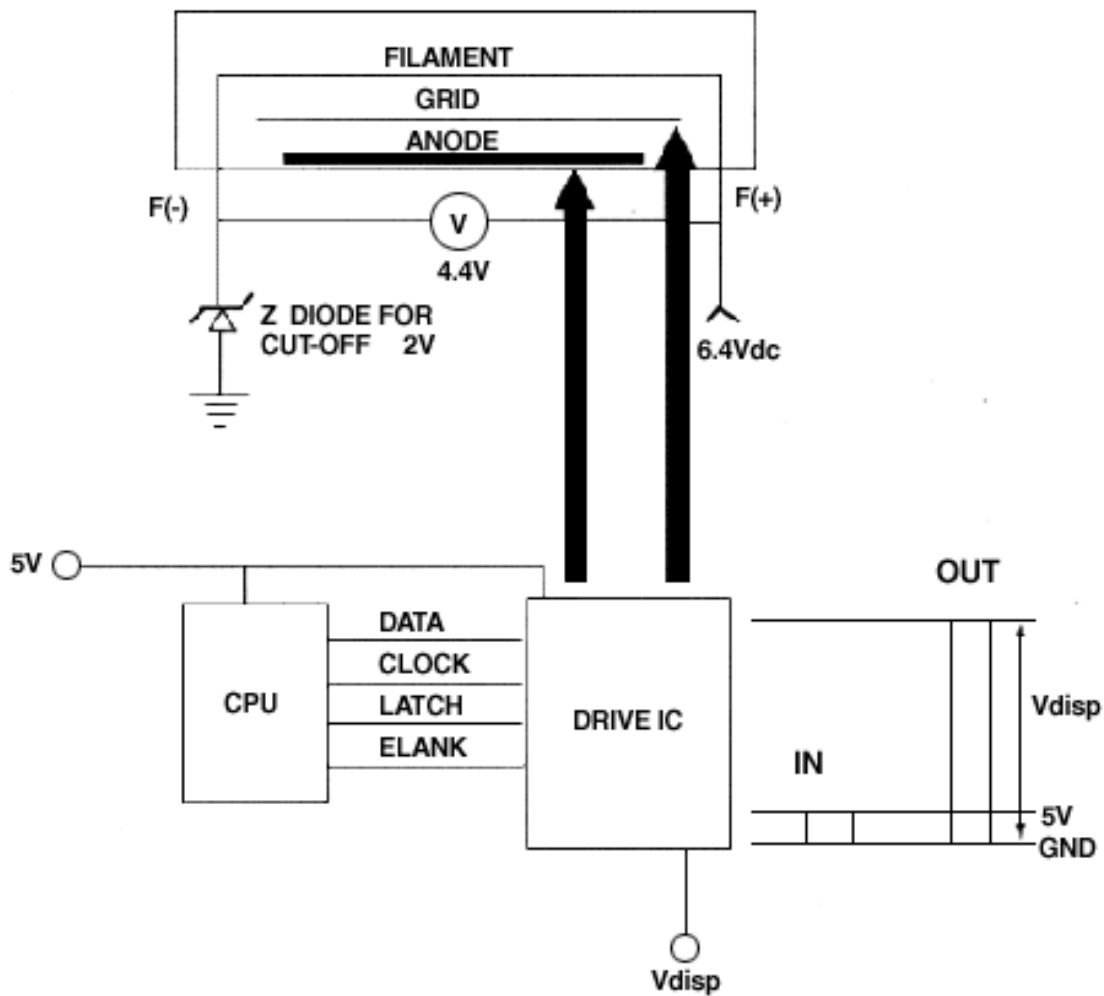

• Positive DC

Ebc:23Vpp
 Ef:4.4Vdc
 Ek:2.0

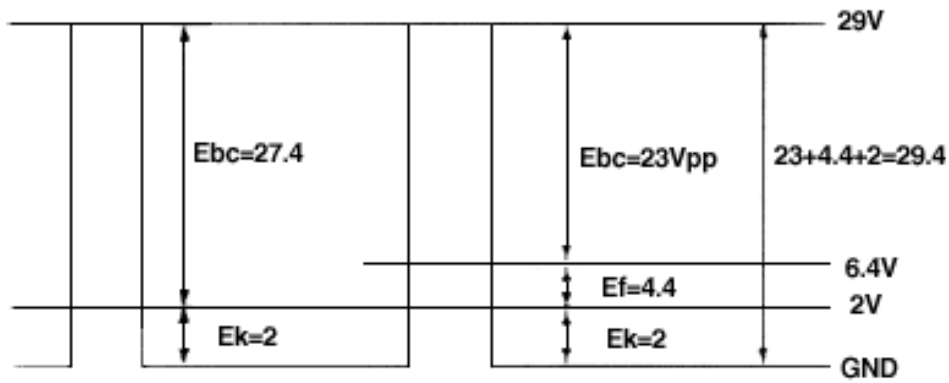

F(-) SIDE

F(+) SIDE

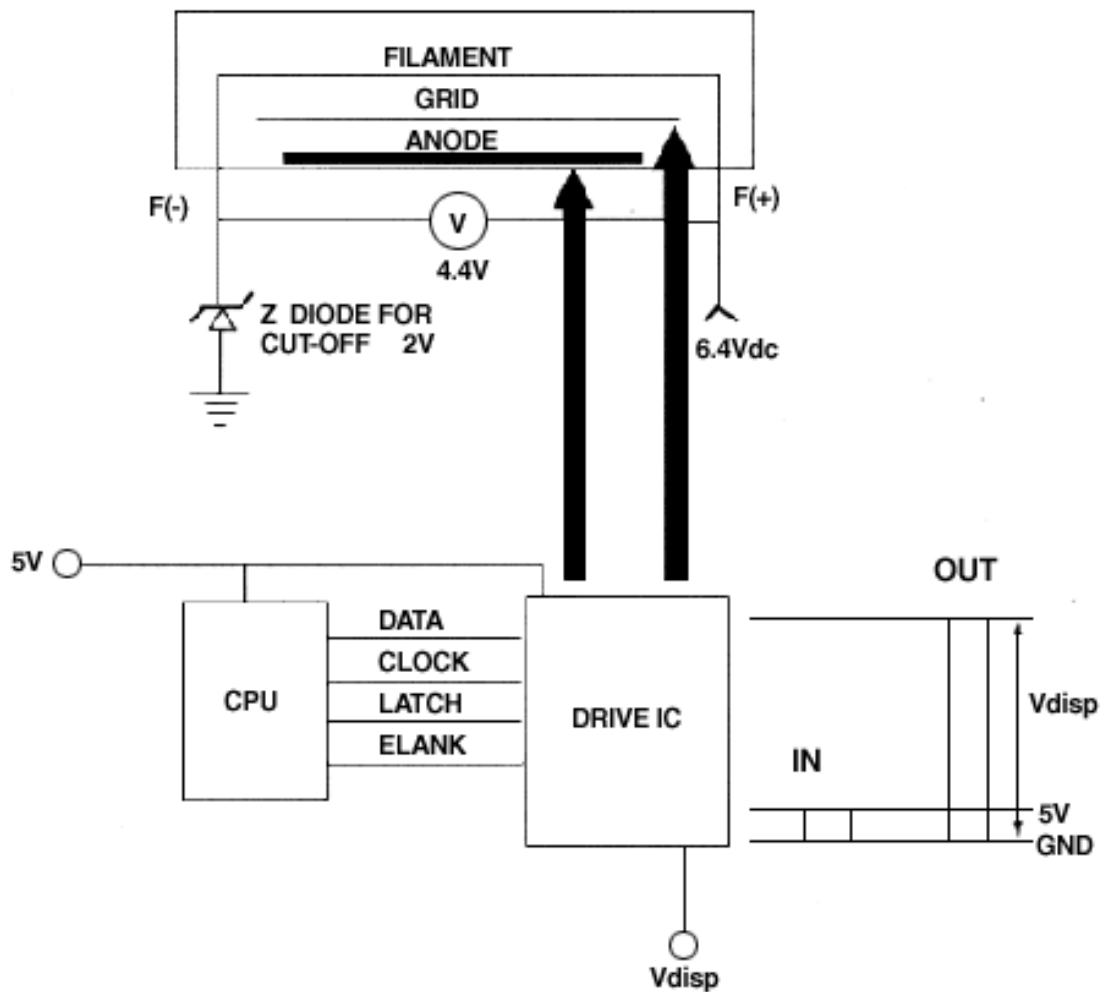

10.9 Driving Circuit

• VFD Basic Driving Circuit (DYNAMIC)

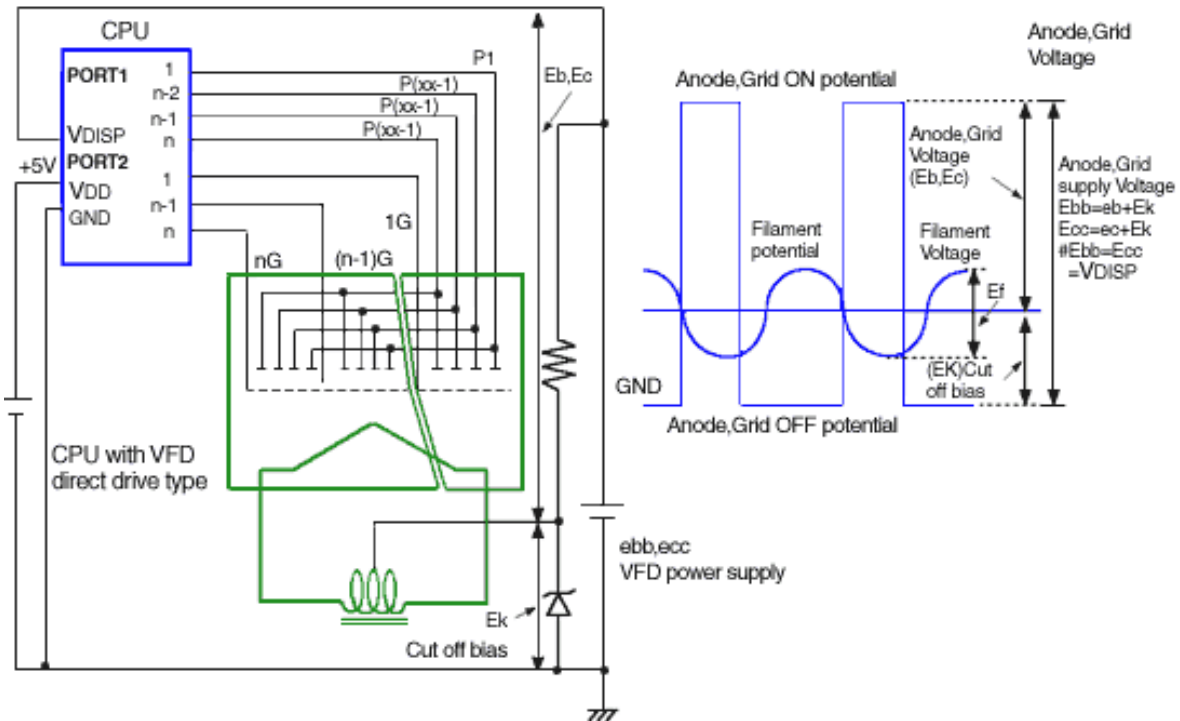

• VFD Basic Driving Circuit (STATIC)

