ML610407/ML610408/ML610409

8-bit Microcontroller with a Built-in LCD driver

GENERAL DESCRIPTION

ML610407/ML610408/ML610409 is a high performance CMOS 8-bit microcontroller into which peripheral circuits, such as the synchronous serial port, UART, melody driver, RC oscillation type A/D converter, and LCD driver, are incorporated around OKI Semiconductor-original 8-bit CPU nX-U8/100. ML610407/ML610408/ML610409 operates in both high/low-speed mode and power-saving mode, it is most suitable for battery operated products.

For industrial use, ML610407P/ML610408P/ML610409P with the extended operating ambient temperature ranging from -40°C to 85°C are available.

FEATURES

- CPU
 - 8-bit RISC CPU (CPU name: nX-U8/100)
 - Instruction system: 16-bit length instruction
 - Instruction set: Transfer, arithmetic operations, comparison, logic operations, multiplication/division, bit manipulations, bit logic operations, jump, conditional jump, call return stack manipulations, arithmetic shift, and so on
 - On-Chip debug function
 - Minimum instruction execution time
 - 30.5 μ s (@ 32.768 kHz system clock)
 - 2 μ s (@ 500 kHz system clock)
 - 0.5 μ s (@ 2 MHz system clock)
- Internal memory
 - Internal 16KByte maskROM (8K x 16 bits) (including unusable 1KByte TEST area)
 - Internal 1KByte RAM (1024 x 8 bits)
- Interrupt controller
 - 1 non-maskable interrupt source:
 - Internal source: 1 (Watchdog Timer)
 - 27 maskable interrupt sources:
 - Internal source: 14 (Synchronous serial port 0, Synchronous serial port 1, Timer 0, Timer 1, Timer 2, Timer 3, UART0, Melody 0, RC Oscillation type A/D converter, PWM0, TBC128Hz, TBC32Hz, TBC16Hz, TBC2Hz)
 - External source: 13 (P00, P01, P02, P03, P04, P50, P51, P52, P53, P54, P55, P56, P57) *

*: For P50 to P57, the interrupt sources are ORed into a single interrupt request.
- Time base counter
 - Low-speed time base counter x 1 channel
 - Frequency compensation (Compensation range: Approx. -488ppm to +488ppm. Compensation accuracy: Approx. 0.48ppm)
 - High-speed time base counter x 1 channel
- Watchdog timer
 - Non-maskable interrupt and reset
 - Free running
 - Overflow period: 4 types selectable (125ms, 500ms, 2s, 8s)
- Timers
 - 8 bits x 4 channels [also available is 16-bit configuration (using Timers 0 and 1, or Timers 2 and 3) x 2 channels]
 - Clock frequency measurement function mode (16-bit configuration using Timers 2 and 3 x 1 channel only)

- Capture
 - Time base capture x 2 channels (4096 Hz to 32 Hz)
- PWM
 - Resolution 16 bits x 1 channel
- Synchronous serial port
 - Master/slave selectable x 2 channels
 - LSB first/MSB first selectable
 - 8-bit length/16-bit length selectable
- UART
 - TXD/RXD × 1 channel
 - Bit length, parity/no parity, odd parity/even parity, 1 stop bit/2 stop bits
 - Positive logic/negative logic selectable
 - Built-in baud rate generator
- Melody driver
 - Scale: 29 types (Melody sound frequency: 508 Hz to 32.768 kHz)
 - Tone length: 63 types
 - Tempo: 15 types
 - Buzzer output mode (4 output modes, 8 frequencies, 16 duty levels)
- RC oscillation type A/D converter
 - 16-bit counter
 - Time division x 2 channels
- General-purpose ports
 - Input-only port: 5 channels (including secondary functions)
 - Output-only port
 - ML610407: 12 channels (including secondary functions)
 - ML610408: 8 channels (including secondary functions)
 - ML610409: 4 channels (including secondary functions)
 - Input/output port: 22 channels (including secondary functions)
- LCD driver
 - Number of segments
 - ML610407: Up to 145 dots (select among 29 segments x 5 commons, 30 segments x 4 commons, 31 segments x 3 commons, and 32 segments x 2 commons)
 - ML610408: Up to 165 dots (select among 33 segments x 5 commons, 34 segments x 4 commons, 35 segments x 3 commons, and 36 segments x 2 commons)
 - ML610409: Up to 185 dots (select among 37 segments x 5 commons, 38 segments x 4 commons, 39 segments x 3 commons, and 40 segments x 2 commons)
 - 1/1 to 1/5 duty
 - 1/2 or 1/3 bias (built-in bias generation circuit)
 - Frame frequency selectable (approx. 64 Hz, 73 Hz, 85 Hz, and 102 Hz)
 - Bias voltage multiplying clock selectable (8 types)
 - LCD drive stop mode, LCD display mode, all LCDs on mode, and all LCDs off mode selectable
 - Programmable display allocation function
- Reset
 - Reset through the RESET_N pin
 - Power-on reset generation when powered on
 - Reset when oscillation stop of the low-speed clock is detected (Cancellation by a mask option is possible)
 - Reset by the watchdog timer (WDT) overflow

- Clock
 - Low-speed clock (Operation of this LSI is not guaranteed under a condition with no supply of low-speed crystal oscillation clock)
Crystal oscillation (32.768 kHz)
 - High-speed clock
Built-in RC oscillation (500 kHz/2 MHz selectable by software)
 - Power management
 - HALT mode: Suspends the instruction execution by CPU (peripheral circuits are in operating states)
 - STOP mode: Stops the low-speed oscillation and high-speed oscillation (Operations of CPU and peripheral circuits are stopped.)
 - High-speed clock gear: The frequency of high-speed system clock can be changed by software (1/1, 1/2, 1/4, or 1/8 of the oscillation clock)
 - Block control function: Completely stops the operation of any function block circuit that is not used (resets registers and stops clock)
 - Shipment
 - Chip (Die)
ML610407-xxxWA
ML610408-xxxWA
ML610409-xxxWA
ML610407P-xxxWA
ML610408P-xxxWA
ML610409P-xxxWA
 - 100-pin plastic TQFP
ML610407-xxxTBZ03A
ML610408-xxxTBZ03A
ML610409-xxxTBZ03A
ML610407P-xxxTBZ03A
ML610408P-xxxTBZ03A
ML610409P-xxxTBZ03A
- xxx: ROM code number (xxx of the blank product is NNN)
P: Wide range temperature version (P version)
WA: Chip (Die)
TBZ03A: TQFP
- Guaranteed Operation Range
 - Operating temperature: -20°C to +70°C (P version: -40°C to +85°C)
 - Operating voltage: $V_{DD} = 1.25V$ to 3.6V

BLOCK DIAGRAM

ML610407/ML610408/ML610409 Block Diagram

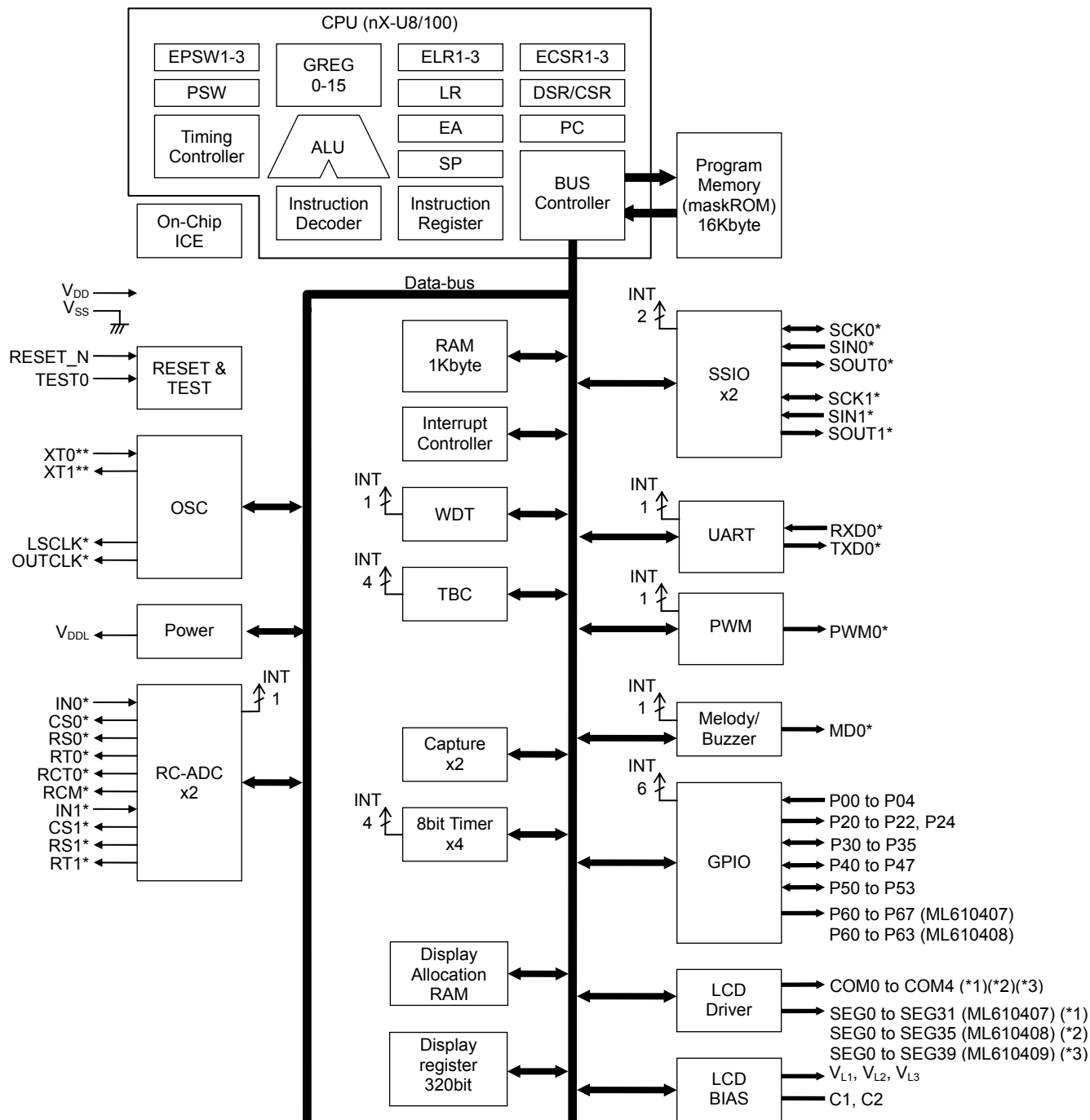

* Secondary function or Tertiary function
 “*1”: Select among 29 segments x 5 commons, 30 segments x 4 commons, 31 segments x 3 commons, and 32 segments x 2 commons with the register
 “*2”: Select among 33 segments x 5 commons, 34 segments x 4 commons, 35 segments x 3 commons, and 36 segments x 2 commons with the register
 “*3”: Select among 37 segments x 5 commons, 38 segments x 4 commons, 39 segments x 3 commons, and 40 segments x 2 commons with the register

Figure 1 ML610413P Block Diagram

PACKAGE PIN/CHIP PAD LAYOUT

ML610407 TQFP Package Pin Layout

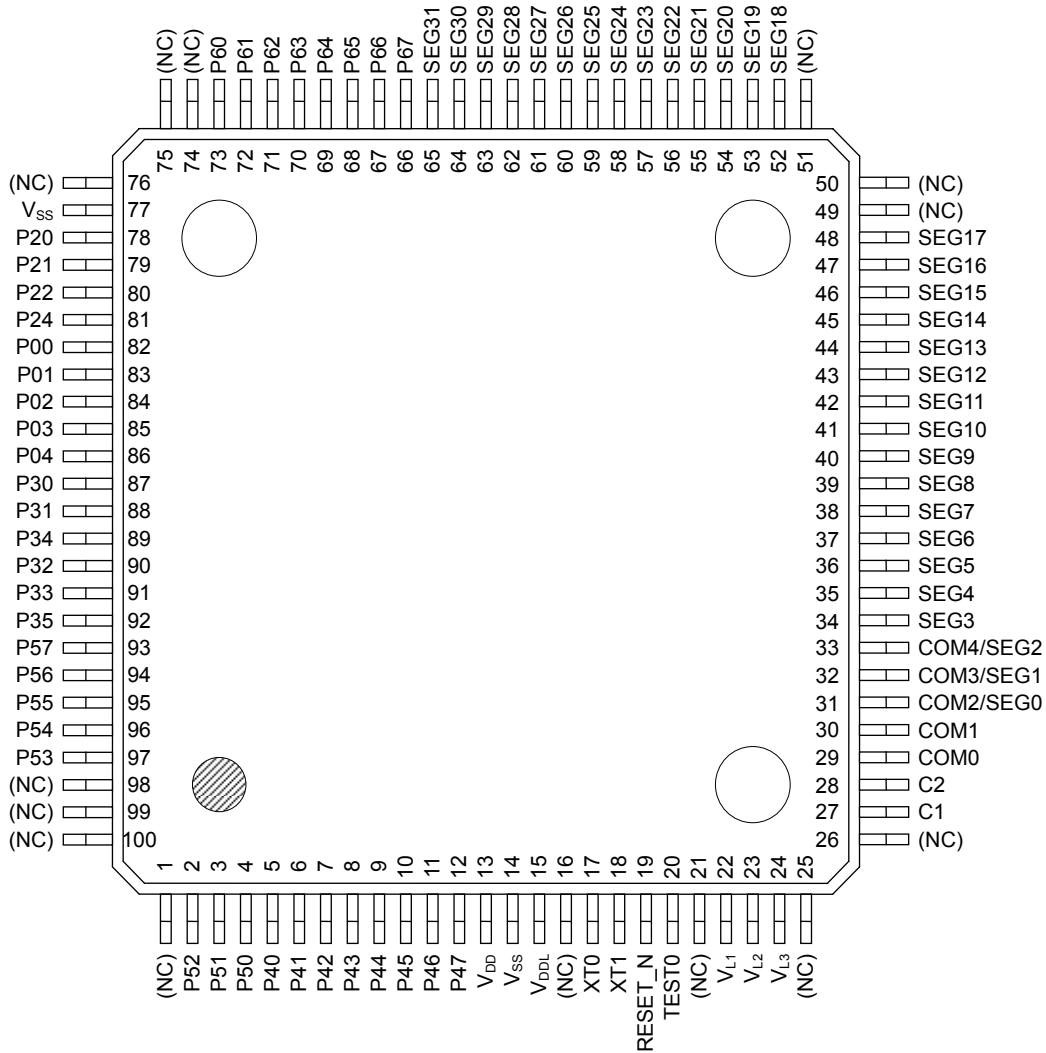

(NC): No Connection

Note:

The assignment of the pads P30 to P35 are not in order.

Figure 2 ML610407 TQFP Package Pin Layout

ML610408 TQFP Package Pin Layout

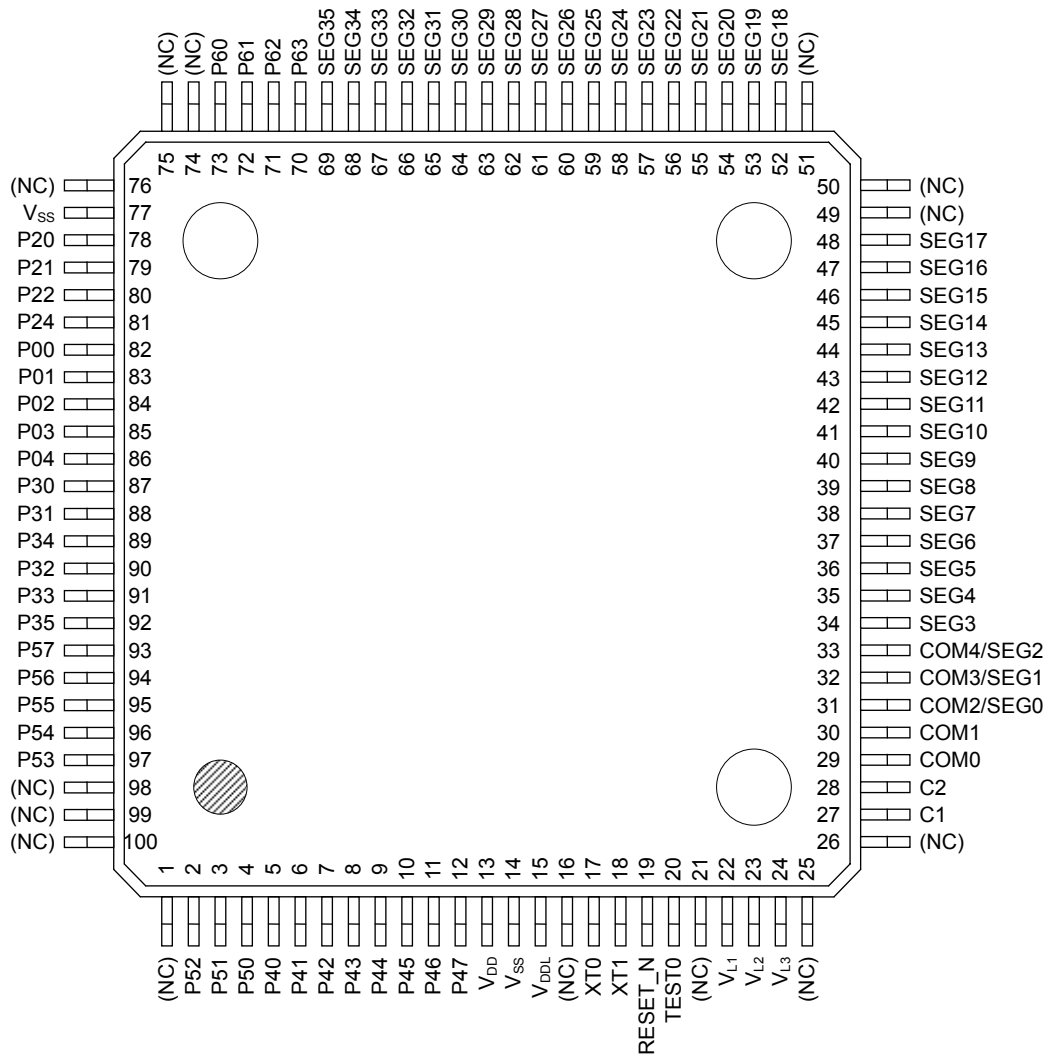

(NC): No Connection

Note:
The assignment of the pads P30 to P35 are not in order.

Figure 3 ML610408 TQFP Package Pin Layout

ML610409 TQFP Package Pin Layout

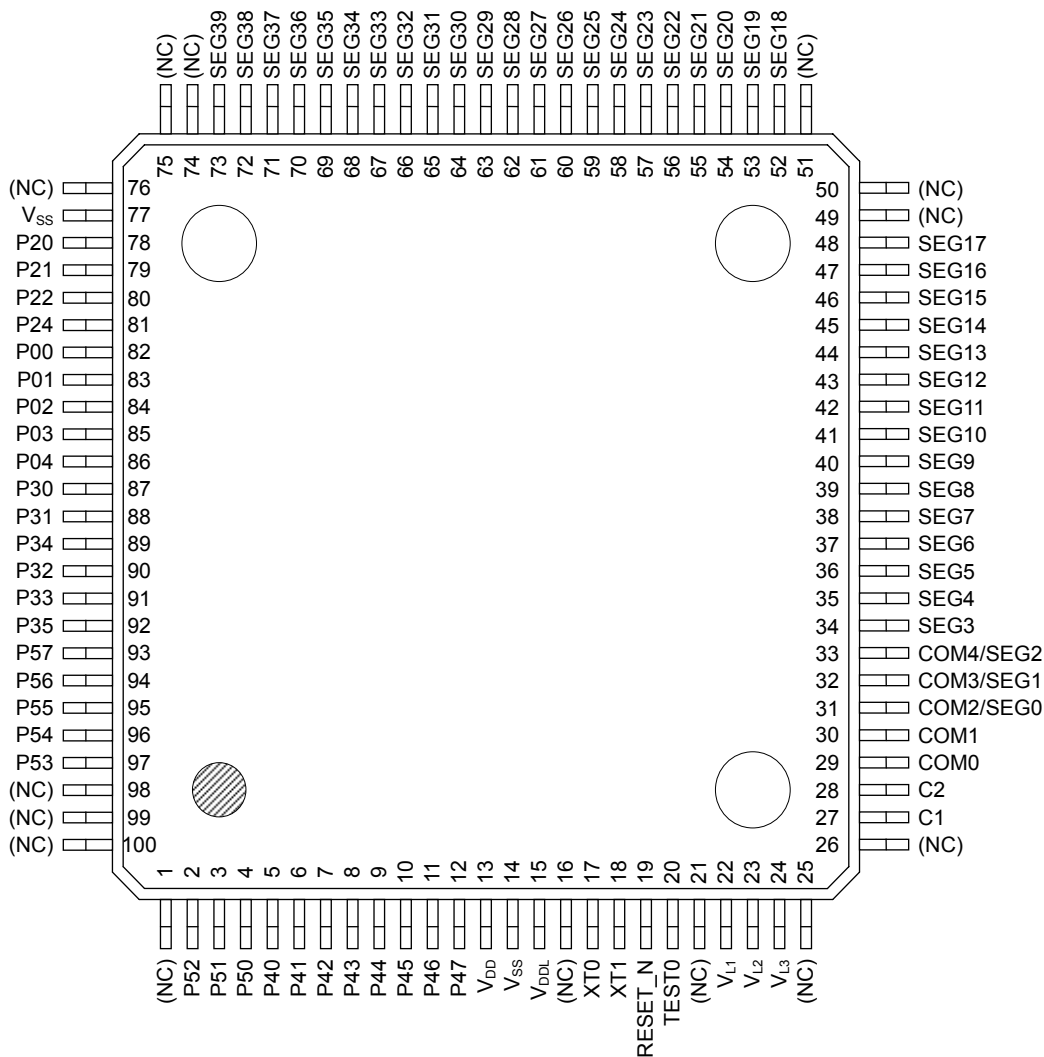

(NC): No Connection

Note:
The assignment of the pads P30 to P35 are not in order.

Figure 4 ML610409 TQFP Package Pin Layout

ML610407 Chip Pad Layout & Dimension

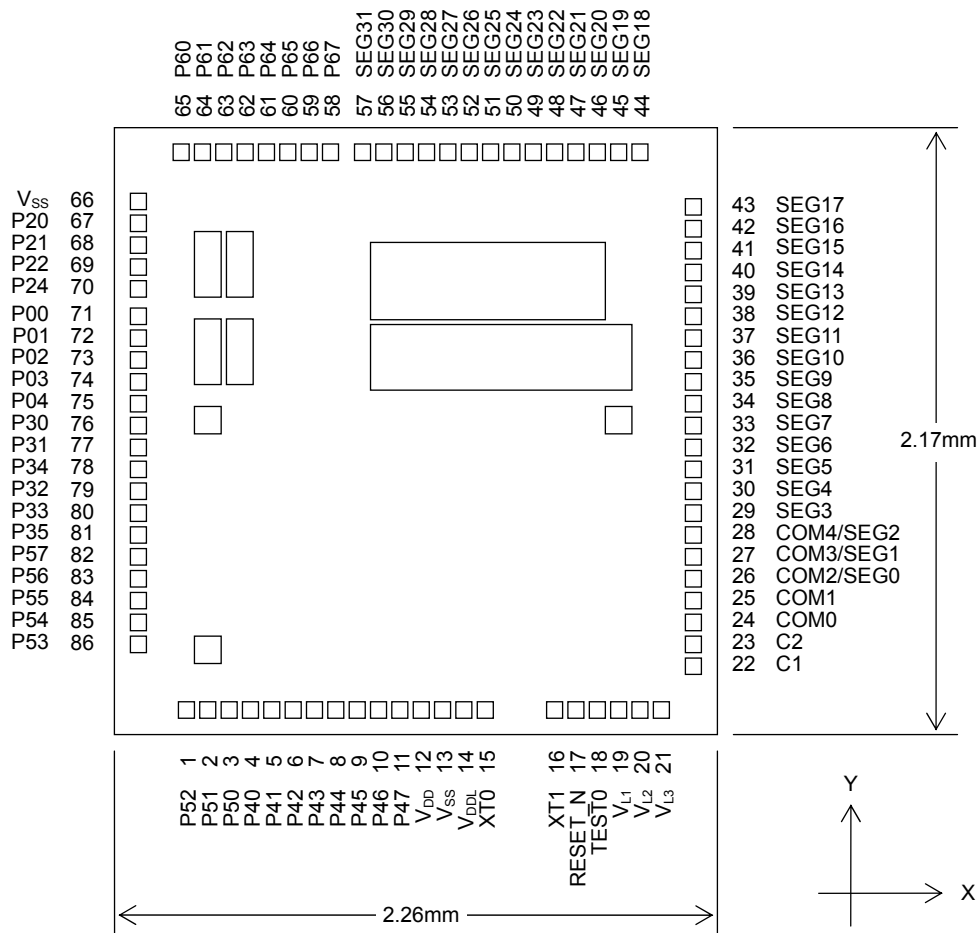

Note:
The assignment of the pads P30 to P35 are not in order.

- Chip size: 2.26 mm × 2.17 mm
- PAD count: 86 pins
- Minimum PAD pitch: 80µm
- PAD aperture: 70µm×70µm
- Chip thickness: 350µm
- Voltage of the rear side of chip: V_{SS} level.

Figure 5 ML610407 Chip Pin Layout & Dimension

ML610408 Chip Pad Layout & Dimension

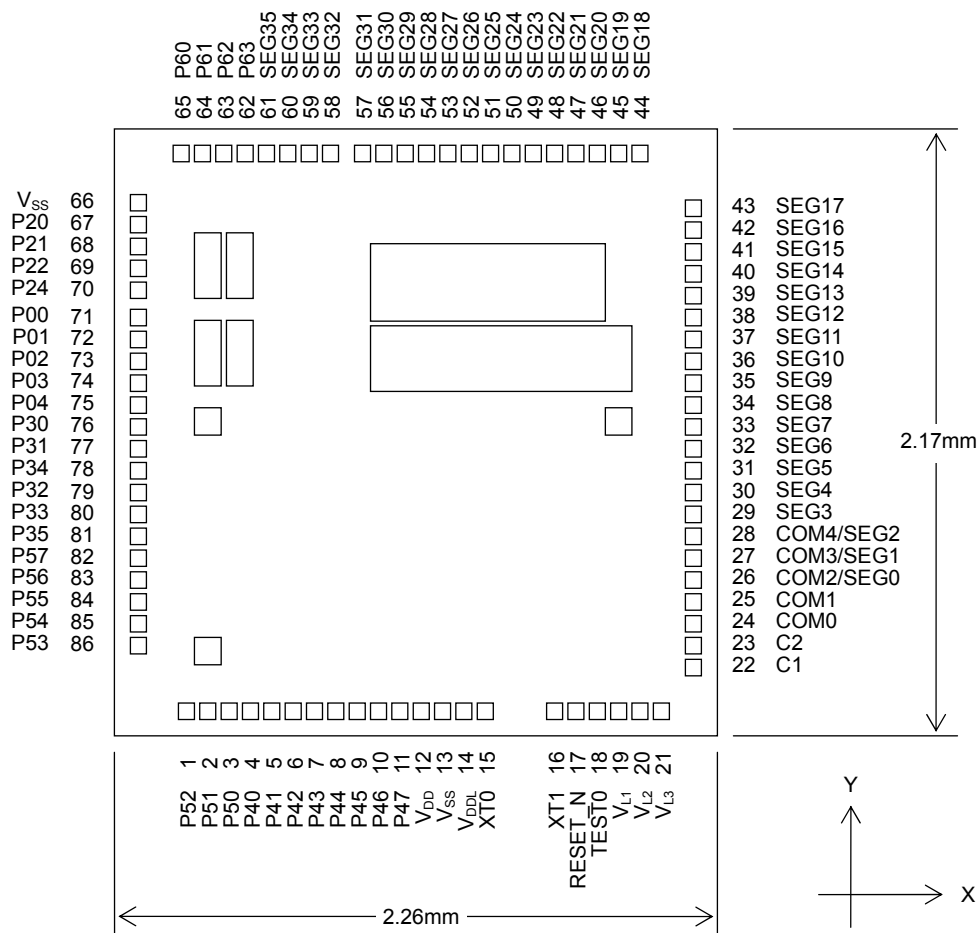

Note:
The assignment of the pads P30 to P35 are not in order.

- Chip size: 2.26 mm × 2.17 mm
- PAD count: 86 pins
- Minimum PAD pitch: 80μm
- PAD aperture: 70μm×70μm
- Chip thickness: 350μm
- Voltage of the rear side of chip: V_{SS} level.

Figure 6 ML610408 Chip Pin Layout & Dimension

ML610409 Chip Pad Layout & Dimension

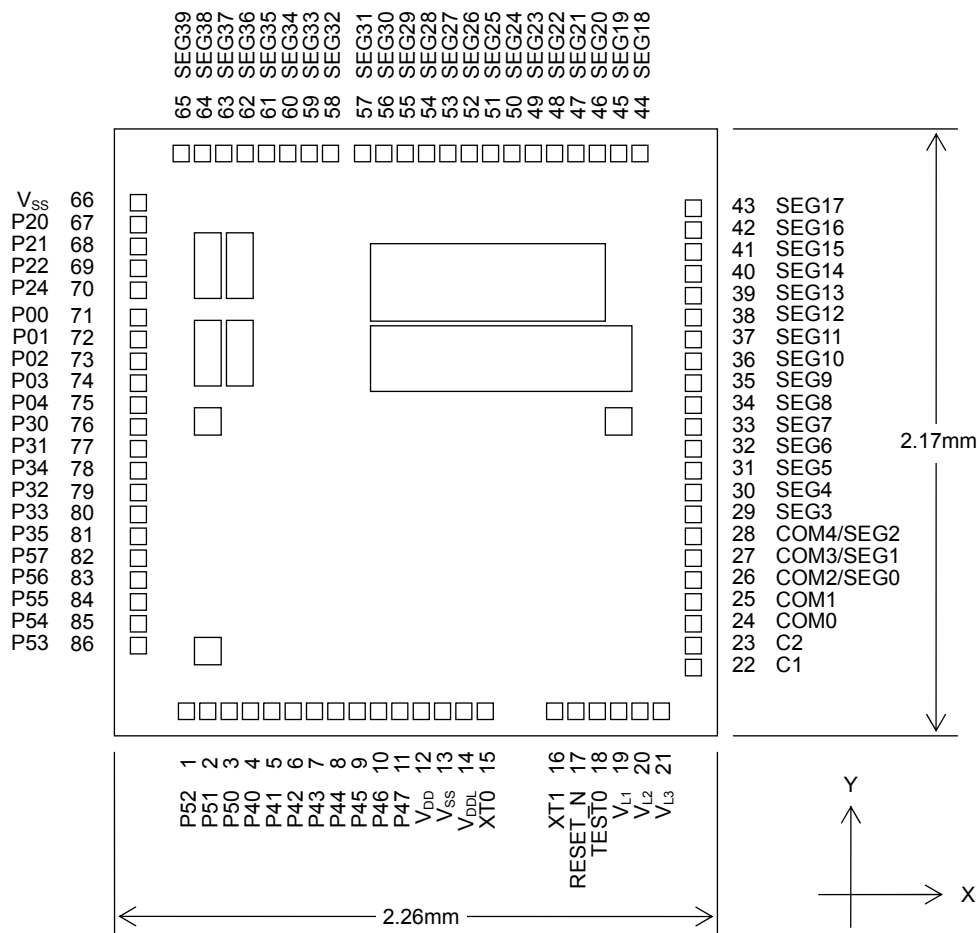

Note:
The assignment of the pads P30 to P35 are not in order.

Chip size: 2.26 mm × 2.17 mm
 PAD count: 86 pins
 Minimum PAD pitch: 80µm
 PAD aperture: 70µm×70µm
 Chip thickness: 350µm
 Voltage of the rear side of chip: V_{SS} level.

Figure 7 ML610409 Chip Pin Layout & Dimension

PAD COORDINATES

ML610407/ML610408/ML610409 Pad Coordinates

Table 1 ML610407/ML610408/ML610409 Pad Coordinates

Chip Center: X=0,Y=0

PAD No.	Pad Name	ML610407/8/9		PAD No.	Pad Name	ML610407/8/9	
		X (μm)	Y (μm)			X (μm)	Y (μm)
1	P52	-853	-979	48	SEG22	520	979
2	P51	-773	-979	49	SEG23	440	979
3	P50	-693	-979	50	SEG24	360	979
4	P40	-613	-979	51	SEG25	280	979
5	P41	-533	-979	52	SEG26	200	979
6	P42	-453	-979	53	SEG27	120	979
7	P43	-373	-979	54	SEG28	40	979
8	P44	-293	-979	55	SEG29	-40	979
9	P45	-213	-979	56	SEG30	-120	979
10	P46	-133	-979	57	SEG31	-200	979
11	P47	-53	-979	58	P67 ^(*)	-295	979
12	V _{DD}	27	-979		SEG32 ^(*)		
13	V _{SS}	107	-979	59	P66 ^(*)	-375	979
14	V _{DDL}	187	-979		SEG33 ^(*)		
15	XT0	267	-979	60	P65 ^(*)	-455	979
16	XT1	427	-979		SEG34 ^(*)		
17	RESET_N	507	-979	61	P64 ^(*)	-535	979
18	TEST0	587	-979		SEG35 ^(*)		
19	V _{L1}	667	-979	62	P63 ^(*)	-615	979
20	V _{L2}	747	-979		SEG36 ^(*)		
21	V _{L3}	827	-979	63	P62 ^(*)	-695	979
22	C1	1024	-845		SEG37 ^(*)		
23	C2	1024	-765	64	P61 ^(*)	-775	979
24	COM0	1024	-685		SEG38 ^(*)		
25	COM1	1024	-605	65	P60 ^(*)	-855	979
26	COM2/SEG0	1024	-525		SEG39 ^(*)		
27	COM3/SEG1	1024	-445	66	V _{SS}	-1024	842
28	COM4/SEG2	1024	-365	67	P20	-1024	762
29	SEG3	1024	-285	68	P21	-1024	682
30	SEG4	1024	-205	69	P22	-1024	602
31	SEG5	1024	-125	70	P24	-1024	522
32	SEG6	1024	-45	71	P00	-1024	422
33	SEG7	1024	35	72	P01	-1024	342
34	SEG8	1024	115	73	P02	-1024	262
35	SEG9	1024	195	74	P03	-1024	182
36	SEG10	1024	275	75	P04	-1024	102
37	SEG11	1024	355	76	P30	-1024	22
38	SEG12	1024	435	77	P31	-1024	-58
39	SEG13	1024	515	78	P34	-1024	-138
40	SEG14	1024	595	79	P32	-1024	-218
41	SEG15	1024	675	80	P33	-1024	-298
42	SEG16	1024	755	81	P35	-1024	-378
43	SEG17	1024	835	82	P57	-1024	-458
44	SEG18	840	979	83	P56	-1024	-538
45	SEG19	760	979	84	P55	-1024	-618
46	SEG20	680	979	85	P54	-1024	-698
47	SEG21	600	979	86	P53	-1024	-778

(*) Pad for ML610407. (**) Pad for ML610408. (***) Pad for ML610409.

PIN LIST

PIN No.	PAD No.	Primary function			Secondary function or Tertiary function			
		Pin name	I/O	Function	Secondary/ Tertiary	Pin name	I/O	Function
14,77	13,66	V _{SS}	—	Negative power supply pin	—	—	—	—
13	12	V _{DD}	—	Positive power supply pin	—	—	—	—
15	14	V _{DDL}	—	Power supply pin for internal logic (internally generated)	—	—	—	—
22	19	V _{L1}	—	Power supply pin for LCD bias (internally generated or connected to positive power supply pin) ⁽²⁾	—	—	—	—
23	20	V _{L2}	—	Power supply pin for LCD bias (internally generated or connected to positive power supply pin) ⁽²⁾	—	—	—	—
24	21	V _{L3}	—	Power supply pin for LCD bias (internally generated)	—	—	—	—
27	22	C1	—	Capacitor connection pin for LCD bias generation	—	—	—	—
28	23	C2	—	Capacitor connection pin for LCD bias generation	—	—	—	—
20	18	TEST0	I/O	Test pin	—	—	—	—
19	17	RESET_N	I	Reset input pin	—	—	—	—
17	15	XT0	I	Low-speed clock oscillation pin	—	—	—	—
18	16	XT1	O	Low-speed clock oscillation pin	—	—	—	—
82	71	P00/EXI0/ CAP0	I	Input port, External interrupt, Capture 0 input	—	—	—	—
83	72	P01/EXI1/ CAP1	I	Input port, External interrupt, Capture 1 input	—	—	—	—
84	73	P02/EXI2/ RXD0	I	Input port, External interrupt, UART0 received data	—	—	—	—
85	74	P03/EXI3	I	Input port, External interrupt	—	—	—	—
86	75	P04/EXI4/ T02P0CK	I	Input port, Timer 0/Timer 2/PWM0 external clock input External interrupt	—	—	—	—
78	67	P20/LED0	O	Output port	Secondary	LSCLK	O	Low-speed clock output
79	68	P21/LED1	O	Output port	Secondary	OUTCLK	O	High-speed clock output
80	69	P22/LED2	O	Output port	Secondary	MD0	O	Melody 0 output
81	70	P24/LED4	O	Output port	Secondary	PWM0	O	PWM0 output
87	76	P30	I/O	Input/output port	Secondary	IN0	I	RC type ADC0 oscillation input pin
88	77	P31	I/O	Input/output port	Secondary	CS0	O	RC type ADC0 reference capacitor connection pin
89	78	P34	I/O	Input/output port	Secondary	RCT0	O	RC type ADC0 resistor/capacitor sensor connection pin
90	79	P32	I/O	Input/output port	Secondary	RS0	O	RC type ADC0 reference resistor connection pin
91	80	P33	I/O	Input/output port	Secondary	RT0	O	RC type ADC0 measurement resistor sensor connection pin
92	81	P35	I/O	Input/output port	Secondary	RCM	O	RC type ADC oscillation monitor

PIN No.	PAD No.	Primary function			Secondary function or Tertiary function			
		Pin name	I/O	Function	Secondary /Tertiary	Pin name	I/O	Function
5	4	P40	I/O	Input/output port	Secondary	—	—	—
					Tertiary	SIN0	I	SSIO0 data input
6	5	P41	I/O	Input/output port	Secondary	—	—	—
					Tertiary	SCK0	I/O	SSIO0 synchronous clock input/output
7	6	P42	I/O	Input/output port	Secondary	RXD0	I	UART data input
					Tertiary	SOUT0	O	SSIO0 data output
8	7	P43	I/O	Input/output port	Secondary	TXD0	O	UART data output
					Tertiary	PWM0	O	PWM0 output
9	8	P44/ T02POCK	I/O	Input/output port, Timer 0/Timer 2/PWM0 external clock input	Secondary	IN1	I	RC type ADC1 oscillation input pin
					Tertiary	SIN0	I	SSIO0 data input
10	9	P45/T13CK	I/O	Input/output port, Timer 1/Timer 3 external clock input	Secondary	CS1	O	RC type ADC1 reference capacitor connection pin
					Tertiary	SCK0	I/O	SSIO0 synchronous clock input/output
11	10	P46	I/O	Input/output port	Secondary	RS1	O	RC type ADC1 reference resistor connection pin
					Tertiary	SOUT0	O	SSIO0 data output
12	11	P47	I/O	Input/output port	Secondary	RT1	O	RC type ADC1 measurement resistor sensor connection pin
4	3	P50/EX18	I/O	Input/output port, External interrupt	Secondary	MD0	O	Melody 0 output
					Tertiary	SIN1	I	SSIO1 data input
3	2	P51/EX18	I/O	Input/output port, External interrupt	Secondary	—	—	—
					Tertiary	SCK1	I/O	SSIO1 synchronous clock input/output
2	1	P52/EX18	I/O	Input/output port, External interrupt	Secondary	—	—	—
					Tertiary	SOUT1	O	SSIO1 data output
97	86	P53/EX18	I/O	Input/output port, External interrupt	—	—	—	—
96	85	P54/EX18	I/O	Input/output port, External interrupt	Secondary	—	—	—
					Tertiary	SIN1	I	SSIO1 data input
95	84	P55/EX18	I/O	Input/output port, External interrupt	Secondary	—	—	—
					Tertiary	SCK1	I/O	SSIO1 synchronous clock input/output
94	83	P56/EX18	I/O	Input/output port, External interrupt	Secondary	—	—	—
					Tertiary	SOUT1	O	SSIO1 data output
93	82	P57/EX18	I/O	Input/output port, External interrupt	—	—	—	—

PIN No.	PAD No.	Primary function			Secondary function or Tertiary function			
		Pin name	I/O	Function	Secondary/Tertiary	Pin name	I/O	Function
29	24	COM0	O	LCD common pin	—	—	—	—
30	25	COM1	O	LCD common pin	—	—	—	—
31	26	COM2/ SEG0	O	LCD common/segment pin	—	—	—	—
32	27	COM3/ SEG1	O	LCD common/segment pin	—	—	—	—
33	28	COM4/ SEG2	O	LCD common/segment pin	—	—	—	—
34	29	SEG3	O	LCD segment pin	—	—	—	—
35	30	SEG4	O	LCD segment pin	—	—	—	—
36	31	SEG5	O	LCD segment pin	—	—	—	—
37	32	SEG6	O	LCD segment pin	—	—	—	—
38	33	SEG7	O	LCD segment pin	—	—	—	—
39	34	SEG8	O	LCD segment pin	—	—	—	—
40	35	SEG9	O	LCD segment pin	—	—	—	—
41	36	SEG10	O	LCD segment pin	—	—	—	—
42	37	SEG11	O	LCD segment pin	—	—	—	—
43	38	SEG12	O	LCD segment pin	—	—	—	—
44	39	SEG13	O	LCD segment pin	—	—	—	—
45	40	SEG14	O	LCD segment pin	—	—	—	—
46	41	SEG15	O	LCD segment pin	—	—	—	—
47	42	SEG16	O	LCD segment pin	—	—	—	—
48	43	SEG17	O	LCD segment pin	—	—	—	—
52	44	SEG18	O	LCD segment pin	—	—	—	—
53	45	SEG19	O	LCD segment pin	—	—	—	—
54	46	SEG20	O	LCD segment pin	—	—	—	—
55	47	SEG21	O	LCD segment pin	—	—	—	—
56	48	SEG22	O	LCD segment pin	—	—	—	—
57	49	SEG23	O	LCD segment pin	—	—	—	—
58	50	SEG24	O	LCD segment pin	—	—	—	—
59	51	SEG25	O	LCD segment pin	—	—	—	—
60	52	SEG26	O	LCD segment pin	—	—	—	—
61	53	SEG27	O	LCD segment pin	—	—	—	—
62	54	SEG28	O	LCD segment pin	—	—	—	—
63	55	SEG29	O	LCD segment pin	—	—	—	—
64	56	SEG30	O	LCD segment pin	—	—	—	—
65	57	SEG31	O	LCD segment pin	—	—	—	—
66	58	P67 ⁽²⁾	O	Output port	—	—	—	—
		SEG32 ⁽³⁾	O	LCD segment pin	—	—	—	—
67	59	P66 ⁽²⁾	O	Output port	—	—	—	—
		SEG33 ⁽³⁾	O	LCD segment pin	—	—	—	—
68	60	P65 ⁽²⁾	O	Output port	—	—	—	—
		SEG34 ⁽³⁾	O	LCD segment pin	—	—	—	—
69	61	P64 ⁽²⁾	O	Output port	—	—	—	—
		SEG35 ⁽³⁾	O	LCD segment pin	—	—	—	—
70	62	P63 ⁽⁴⁾	O	Output port	—	—	—	—
		SEG36 ⁽⁵⁾	O	LCD segment pin	—	—	—	—
71	63	P62 ⁽⁴⁾	O	Output port	—	—	—	—
		SEG37 ⁽⁵⁾	O	LCD segment pin	—	—	—	—
72	64	P61 ⁽⁴⁾	O	Output port	—	—	—	—
		SEG38 ⁽⁵⁾	O	LCD segment pin	—	—	—	—
73	65	P60 ⁽⁴⁾	O	Output port	—	—	—	—
		SEG39 ⁽⁵⁾	O	LCD segment pin	—	—	—	—

(*¹) Internally generated, or connect to either positive power supply pin (V_{DD}) or power supply pin for internal logic (V_{DDL}). For details, see "Chapter 22 LCD Drivers."

(*²) Pin for ML610407/ML610408

(*³) Pin for ML610409

(*⁴) Pin for ML610407

(*⁵) Pin for ML610408/ML610409

PIN DESCRIPTION

Pin name	I/O	Description	Primary/ Secondary/ Tertiary	Logic
System				
RESET_N	I	Reset input pin. When this pin is set to a "L" level, system reset mode is set and the internal section is initialized. When this pin is set to a "H" level subsequently, program execution starts. A pull-up resistor is internally connected.	—	Negative
XT0	I	Crystal connection pin for low-speed clock. A 32.768 kHz crystal resonator is connected to this pin. Capacitors	—	—
XT1	O	C _{DL} and C _{GL} are connected across this pin and V _{SS} . (see appendix C measuring circuit 1)	—	—
LSCLK	O	Low-speed clock output. Assigned to the secondary function of the P20 pin.	Secondary	—
OUTCLK	O	High-speed clock output pin. This pin is used as the secondary function of the P21 pin.	Secondary	—
General-purpose input port				
P00 to P04	I	General-purpose input port.	Primary	Positive
General-purpose output port				
P20 to P22, P24	O	General-purpose output port. This cannot be used as the general output port when used as the secondary function.	Primary	Positive
General-purpose input/output port				
P30 to P35	I/O	General-purpose input/output port. This cannot be used as the general input/output port when used as the secondary function.	Primary	Positive
P40 to P47	I/O	General-purpose input/output port. This cannot be used as the general input/output port when used as the secondary or tertiary function.	Primary	Positive
P50 to P57	I/O	General-purpose input/output port. This cannot be used as the general input/output port when used as the secondary function.	Primary	Positive
P60 to P63	O	General-purpose output port. Incorporated only into ML610407/8, and not into ML610409.	Primary	Positive
P64 to P67	O	General-purpose output port. Incorporated only into ML610407, and not into ML610408/ ML610409.	Primary	Positive

Pin name	I/O	Description	Primary/ Secondary/ Tertiary	Logic
UART				
TXD0	O	UART data output pin. This pin is used as the secondary function of the P43 pin.	Secondary	Positive
RXD0	I	UART data input pin. This pin is used as the secondary function of the P42 or the primary function of the P02 pin.	Primary/ Secondary	Positive
Synchronous serial (SSIO)				
SCK0	I/O	Synchronous serial clock input/output pin. This pin is used as the tertiary function of the P41 or P45 pin.	Tertiary	—
SIN0	I	Synchronous serial data input pin. This pin is used as the tertiary function of the P40 or P44 pin.	Tertiary	Positive
SOUT0	O	Synchronous serial data output pin. This pin is used as the tertiary function of the P42 or P46 pin.	Tertiary	Positive
SCK1	I/O	Synchronous serial clock input/output pin. Assigned to the tertiary function of the P51 pin and P54 pin.	Tertiary	—
SIN1	I	Synchronous serial data input pin. Assigned to the tertiary function of the P50 pin and P54 pin.	Tertiary	Positive
SOUT1	O	Synchronous serial data output pin. Assigned to the tertiary function of the P52 pin and P56 pin.	Tertiary	Positive
PWM				
PWM0	O	PWM0 output pin. This pin is used as the secondary function of the P24 and tertiary function of the P43 pin.	Secondary Tertiary	Positive
TOP02CK	O	PWM0 external clock input pin. This pin is used as the primary function of the P04 pin and P44 pin.	Primary	—
External interrupt				
EXI0-4	I	External maskable interrupt input pins. Interrupt enable and edge selection can be performed for each bit by software. These pins are used as the primary functions of the P00 to P04 pins.	Primary	Positive/ negative
EXI8	I	External maskable interrupt input pins. Interrupt enable and edge selection can be performed for each bit by software. Assigned to the primary function of the P50 to P57 pins.	Primary	Positive/ negative
Capture				
CAP0	I	Capture trigger input pins. The value of the time base counter is captured in the register synchronously with the interrupt edge selected by software. These pins are used as the primary functions of the P00 pin(CAP0) and P01 pin(CAP1).	Primary	Positive/ negative
CAP1	I		Primary	Positive/ negative
Timer				
TOP02CK	I	External clock input pin used for both Timer 0 and Timer 2. This pin is used as the primary function of the P04 pin and P44 pin.	Primary	—
T13CK	I	External clock input pin used for both Timer 1 and Timer 3. This pin is used as the primary function of the P45 pin.	Primary	—
Melody				
MD0	O	Melody/buzzer signal output pin. This pin is used as the secondary function of the P22 and P50 pins.	Secondary	Positive/ negative
LED drive				
LED0 to LED2, LED4	O	N-channel open drain output pins to drive LED. This pin is used as the primary function of the P20 to P22 and P24 pins.	Primary	Positive /negative

Pin name	I/O	Description	Primary/ Secondary/ Tertiary	Logic
UART				
TXD0	O	UART data output pin. This pin is used as the secondary function of the P43 pin.	Secondary	Positive
RXD0	I	UART data input pin. This pin is used as the secondary function of the P42 or the primary function of the P02 pin.	Primary/ Secondary	Positive
Synchronous serial (SSIO)				
SCK0	I/O	Synchronous serial clock input/output pin. This pin is used as the tertiary function of the P41 or P45 pin.	Tertiary	—
SIN0	I	Synchronous serial data input pin. This pin is used as the tertiary function of the P40 or P44 pin.	Tertiary	Positive
SOUT0	O	Synchronous serial data output pin. This pin is used as the tertiary function of the P42 or P46 pin.	Tertiary	Positive
SCK1	I/O	Synchronous serial clock input/output pin. Assigned to the tertiary function of the P51 pin and P54 pin.	Tertiary	—
SIN1	I	Synchronous serial data input pin. Assigned to the tertiary function of the P50 pin and P54 pin.	Tertiary	Positive
SOUT1	O	Synchronous serial data output pin. Assigned to the tertiary function of the P52 pin and P56 pin.	Tertiary	Positive
PWM				
PWM0	O	PWM0 output pin. This pin is used as the secondary function of the P24 and tertiary function of the P43 pin.	Secondary Tertiary	Positive
T0P02CK	O	PWM0 external clock input pin. This pin is used as the primary function of the P04 pin and P44 pin.	Primary	—
External interrupt				
EXI0-4	I	External maskable interrupt input pins. Interrupt enable and edge selection can be performed for each bit by software. These pins are used as the primary functions of the P00 to P04 pins.	Primary	Positive/ negative
EXI8	I	External maskable interrupt input pins. Interrupt enable and edge selection can be performed for each bit by software. Assigned to the primary function of the P50 to P57 pins.	Primary	Positive/ negative
Capture				
CAP0	I	Capture trigger input pins. The value of the time base counter is captured in the register synchronously with the interrupt edge selected by software. These pins are used as the primary functions of the P00 pin(CAP0) and P01 pin(CAP1).	Primary	Positive/ negative
CAP1	I		Primary	Positive/ negative
Timer				
T0P02CK	I	External clock input pin used for both Timer 0 and Timer 2. This pin is used as the primary function of the P04 pin and P44 pin.	Primary	—
T13CK	I	External clock input pin used for both Timer 1 and Timer 3. This pin is used as the primary function of the P45 pin.	Primary	—
Melody				
MD0	O	Melody/buzzer signal output pin. This pin is used as the secondary function of the P22 and P50 pins.	Secondary	Positive/ negative
LED drive				
LED0 to LED2, LED4	O	N-channel open drain output pins to drive LED. This pin is used as the primary function of the P20 to P22 and P24 pins.	Primary	Positive /negative

Pin name	I/O	Description	Primary/ Secondary/ Tertiary	Logic
RC oscillation type A/D converter				
IN0	I	Channel 0 oscillation input pin. This pin is used as the secondary function of the P30 pin.	Secondary	—
CS0	O	Channel 0 reference capacitor connection pin. This pin is used as the secondary function of the P31 pin.	Secondary	—
RS0	O	This pin is used as the secondary function of the P32 pin which is the reference resistor connection pin of Channel 0.	Secondary	—
RCT0	O	Resistor/capacitor sensor connection pin of Channel 0 for measurement. This pin is used as the secondary function of the P34 pin.	Secondary	—
RT0	O	Resistor sensor connection pin of Channel 0 for measurement. This pin is used as the secondary function of the P33 pin.	Secondary	—
RCM	O	RC oscillation monitor pin. This pin is used as the secondary function of the P35 pin.	Secondary	—
IN1	I	Oscillation input pin of Channel 1. This pin is used as the secondary function of the P44 pin.	Secondary	—
CS1	O	Reference capacitor connection pin of Channel 1. This pin is used as the secondary function of the P45 pin.	Secondary	—
RS1	O	Reference resistor connection pin of Channel 1. This pin is used as the secondary function of the P46 pin.	Secondary	—
RT1	O	Resistor sensor connection pin for measurement of Channel 1. This pin is used as the secondary function of the P47 pin.	Secondary	—
LCD drive signal				
COM0 to COM4	O	Common output pins. COM2, COM3, and COM4 can be switched to SEG0, SEG1, and SEG2, respectively, through the register setting. To change the setting, switch between COM4 and SEG2 for one pin and switch between COM3, COM4 and SEG1, SEG2 for two pins.	—	—
SEG0 to SEG23	O	Segment output pin. The SEG0, SEG1, and SEG2 pins are for switching the register setting with the COM2, COM3, and COM4.	—	—
SEG24 to SEG27	O	Segment output pin. Incorporated into ML610408/ML610409, not into ML610407.	—	—
SEG28 to SEG31	O	Segment output pin. Incorporated into ML610409, not into ML610407/ML610408.	—	—
LCD driver power supply				
V _{L1}	—	Power supply pin for LCD bias (internally generated) or power supply connection pin. Depending on LCD Bias setting and V _{DD} voltage level, V _{DD} or V _{DDL} or capacitor is connected. For details of the connection method, see Chapter 22, "LCD Drivers".	—	—
V _{L2}	—		—	—
V _{L3}	—		—	—
C1	—	Power supply pins for LCD bias (internally generated). Capacitor	—	—
C2	—	C ₁₂ (see Appendix C measuring circuit 1) is connected between C1 and C2.	—	—

Pin name	I/O	Description	Primary/ Secondary/ Tertiary	Logic
Test				
TEST0	I/O	Pin for testing. A pull-down resistor is internally connected.	—	Positive
Power supply				
V _{SS}	—	Negative power supply pin.	—	—
V _{DD}	—	Positive power supply pin.	—	—
V _{DDL}	—	Positive power supply pin (internally generated) for internal logic. Capacitors C _{L0} and C _{L1} (see Appendix C measuring circuit 1) are connected between this pin and V _{SS} .	—	—

TERMINATION OF UNUSED PINS

Table 2 shows methods of terminating the unused pins.

Table 2 Termination of Unused Pins

Pin	Recommended pin handling
V _{L1}	Open
V _{L2}	Open
V _{L3}	Open
C1, C2	Open
RESET_N	Open
TEST0	Open
P00 to P04	V _{DD} or V _{SS}
P20 to P22, P24	Open
P30 to P35	Open
P40 to P47	Open
P50 to P57	Open
P60 to P67	Open
COM0 to COM4	Open
SEG0 to SEG39	Open
Pin	Recommended pin handling
VL1	Open
VL2	Open
VL3	Open
C1, C2	Open
RESET_N	Open
TEST0	Open
P00 to P04	VDD or VSS
P20 to P22, P24	Open
P30 to P35	Open
P40 to P47	Open
P50 to P57	Open
P60 to P67	Open
COM0 to COM4	Open
SEG0 to SEG39	Open

Note:

It is recommended to set the unused input ports and input/output ports to the inputs with pull-down resistors/pull-up resistors or the output mode since the supply current may become excessively large if the pins are left open in the high impedance input setting.

ELECTRICAL CHARACTERISTICS

Absolute Maximum Ratings

(V_{SS}= 0V)

Parameter	Symbol	Condition	Rating	Unit
Power supply voltage 1	V _{DD}	Ta=25°C	-0.3 to +4.6	V
Power supply voltage 2	V _{DDL}	Ta=25°C	-0.3 to +3.6	V
Power supply voltage 3	V _{L1}	Ta=25°C	-0.3 to +2.0	V
Power supply voltage 4	V _{L2}	Ta=25°C	-0.3 to +4.0	V
Power supply voltage 5	V _{L3}	Ta=25°C	-0.3 to +6.0	V
Input voltage	V _{IN}	Ta=25°C	-0.3 to V _{DD} +0.3	V
Output voltage	V _{OUT}	Ta=25°C	-0.3 to V _{DD} +0.3	V
output current 1	I _{OUT1}	Port 3 to 6, Ta=25°C	-12 to +11	mA
Output current 2	I _{OUT2}	Port 2, Ta=25°C	-12 to +20	mA
Power dissipation	PD	Ta=25°C	0.9	W
Storage temperature	T _{STG}	—	-55 to +150	°C

Recommended Operating conditions

(V_{SS}= 0V)

Parameter	Symbol	Condition	Range	Unit
Operating temperature	T _{OP}	without P version	-20 to +70	°C
		P version	-40 to +85	
Operating voltage	V _{DD}	f _{OP} =30k to 625kHz	1.25 to 3.6	V
		f _{OP} =30k to 2.5MHz	1.8 to 3.6	
Operating frequency (CPU)	f _{OP}	V _{DD} =1.25 to 3.6V	30k to 625k	Hz
		V _{DD} =1.8 to 3.6V	30k to 2.5M	
Low-speed crystal oscillation frequency	f _{XTL}	—	32.768k	Hz
Low-speed crystal oscillation external capacitance	C _{DL}	—	3 to 18	pF
	C _{GL}	—	3 to 18	
V _{DDL} pin external capacitance	C _L	—	0.47±30%	μF
V _{L1, 2, or 3} pin external capacitance	C _{a,b,c}	—	0.1±30%	μF
Pin-to-pin (C1 to C2) external capacitance	C ₁₂	—	0.47±30%	μF

DC Characteristics (1/5)

(VDD=1.25 to 3.6V, VSS=0V, Ta=-20 to +70°C, Ta=-40 to +85°C for P version, unless otherwise specified)

Parameter	Symbol	Condition	Rating			Unit	Measur ement circuit
			Min.	Typ.	Max.		
500kHz/2MHz RC oscillation frequency	f _{RC}	V _{DD} =1.25 to 3.6V	Ta=25°C	Typ. -10%	500	Typ. +10%	kHz
			*3	Typ. -25%	500	Typ. +25%	
		V _{DD} =1.8 to 3.6V	Ta=25°C	Typ. -10%	2.0	Typ. +10%	MHz
			*3	Typ. -25%	2.0	Typ. +25%	MHz
Low-speed crystal oscillation start time*2	T _{XTL}	—	—	0.6	2	s	1
500kHz/2MHz RC oscillation start time	T _{RC}	—	—	—	3	μs	
Low-speed oscillation stop detect time*1	T _{STOP}	—	12	16.4	41	ms	
Reset pulse width	P _{RST}	—	200	—	—	μs	
Reset noise elimination pulse width	P _{NRST}	—	—	—	0.3		
Power-on reset generated power rise time	T _{POR}	—	—	—	10	ms	

*1: When low-speed crystal oscillation stops for a duration more than the low-speed oscillation stop detect time, the system is reset to shift to system reset mode.

*2: 32.768kHz crystal resonator DT-26 (Load capacitance 6pF) (made by KDS:DAISHINKU CORP.) is used (C_{GL}=C_{DL}=12pF).

*3: Recommended operating temperature (Ta=-20 to 70°C, Ta=-40 to 85°C for P version)

RESET

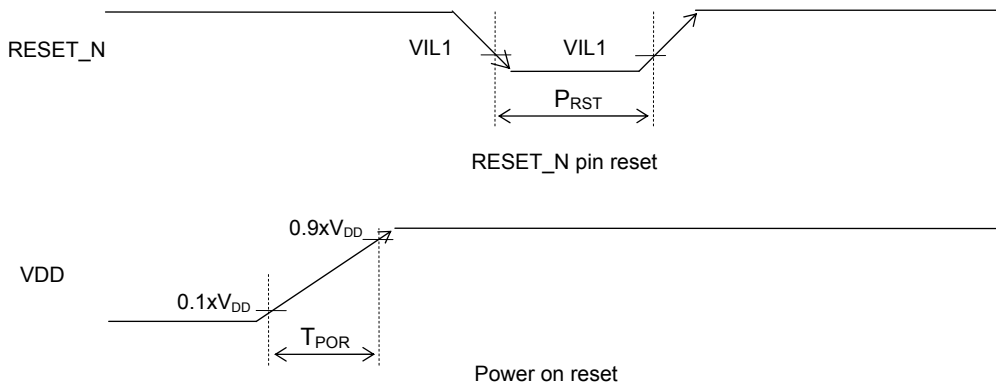

DC Characteristics (2/5)

(VDD=1.25 to 3.6V, VSS=0V, Ta=-20 to +70°C, Ta=-40 to +85°C for P version, unless otherwise specified)

Parameter	Symbol	Condition	Rating			Unit	Measurement circuit
			Min.	Typ.	Max.		
V _{DDL} voltage	V _{DDL}	fop=30k to 625kHz	1.1	1.2	1.3	V	1
		fop=30k to 2.5MHz	1.35	1.5	1.65		
V _{DDL} temperature deviation * ¹	ΔV _{DDL}	V _{DD} =3.0V	—	-1	—	mV/°C	
V _{DDL} voltage dependency * ¹	ΔV _{DDL}	—	—	5	20	mV/V	

*¹: The maximum V_{DDL} voltage becomes the V_{DD} voltage level when the V_{DDL} voltage determined by the temperature and voltage deviations mathematically exceeds the V_{DD} voltage.

DC Characteristics (3/5)

(VDD=3.0V, VSS=0V, Ta=-20 to +70°C, Ta=-40 to +85°C for P version, unless otherwise specified)

Parameter	Symbol	Condition		Rating			Unit	Measurement circuit
				Min.	Typ.	Max.		
Supply current 1	IDD1	CPU: In STOP state. Low-speed/High-speed oscillation: stopped.	Ta=25°C	—	0.4	0.8	μA	1
			* ⁵	—	—	6.5		
Supply current 2	IDD2	CPU: In HALT state. (LTBC, WDT: Operating)* ^{3,4} . High-speed 500kHz/2MHz oscillation: Stopped. LCD/BIAS circuits: Operating * ⁶	Ta=25°C	—	0.9	1.8	μA	
			* ⁵	—	—	7.5		
Supply current 3	IDD3	CPU: In 32.768kHz operating state.* ^{1,3} High-speed 500kHz/2MHz oscillation: Stopped, LCD/BIAS circuits: Operating * ²	Ta=25°C	—	4.0	7.5	μA	
			* ⁵	—	—	11.0		
Supply current 4-1	IDD4-1	CPU: In 500kHz RC operating state. LCD/BIAS circuits: Operating.* ²	Ta=25°C	—	60	80	μA	
			* ⁵	—	—	90		
Supply current 4-2	IDD4-2	CPU: In 2MHz RC operating state. LCD/BIAS circuits: Operating.* ²	Ta=25°C	—	240	300	μA	
			* ⁵	—	—	320		

*¹: When the CPU operating rate is 100% (no HALT state).

*²: All SEGs: off waveform, No LCD panel load, 1/3 bias, 1/3 duty, Frame frequency: Approx. 64 Hz, Bias voltage multiplying clock: 1/128 LSCLK (256Hz)

*³: 32.768KHz crystal resonator DT-26 (Load capacitance 6pF) (made by KDS:DAISHINKU CORP.) is used (C_{GL}=C_{DL}=6pF)

*⁴: Significant bits of BLKCON0 to BLKCON4 registers are all "1" except DLCD bit on BLKCON4.

*⁵: Recommended operating temperature (Ta=-20 to 70°C, Ta=-40 to 85°C for P version)

*⁶: LCD stop mode, 1/3 bias, Bias voltage multiplying clock: 1/128 LSCLK (256Hz)

DC Characteristics (4/5)

(V_{DD}=1.25 to 3.6V, V_{SS}=0V, T_a=-20 to +70°C, T_a=-40 to +85°C for P version, unless otherwise specified)

Parameter	Symbol	Condition	Rating			Unit	Measurement circuit
			Min.	Typ.	Max.		
Output voltage 1 (P20 to P22, P24 (N-channel open drain output mode is not selected)) (P30 to P35) (P40 to P47) (P50 to P57) (P60 to P63) ^{*1,2} (P64 to P67) ^{*1}	VOH1	IOH1=-0.5mA, V _{DD} =1.8 to 3.6V	V _{DD} -0.5	—	—	V	2
		IOH1=-0.03mA, V _{DD} =1.25 to 3.6V	V _{DD} -0.3	—	—		
	VOL1	IOL1=+0.5mA, V _{DD} =1.8 to 3.6V	—	—	0.5		
		IOL1=+0.1mA, V _{DD} =1.25 to 3.6V	—	—	0.3		
Output voltage 2 (P20 to P22, P24 (N-channel open drain output mode is selected))	VOL2	IOL2=+5mA, V _{DD} =1.8 to 3.6V	—	—	0.5	V	2
Output voltage 3 (COM0 to 4) (SEG0 to 31) ^{*1} (SEG0 to 35) ^{*2} (SEG0 to 39) ^{*3}	VOH3	IOH3=-0.05mA, VL1=1.2V	V _{L3} -0.2	—	—	μA	3
	VOML3	IOML3=+0.05mA, VL1=1.2V	—	—	V _{L2} +0.2		
	VOML3S	IOML3S=-0.05mA, VL1=1.2V	V _{L2} -0.2	—	—		
	VOLM3	IOLM3=+0.05mA, VL1=1.2V	—	—	V _{L1} +0.2		
	VOLM3S	IOLM3S=-0.05mA, VL1=1.2V	V _{L1} -0.2	—	—		
	VOL3	IOL3=+0.05mA, VL1=1.2V	—	—	0.2		
Output leakage (P20 to P22, P24) (P30 to P35) (P40 to P47) (P50 to P57) (P60 to P63) ^{*1,2} (P60 to P67) ^{*1}	IOOH	VOH=V _{DD} (in high-impedance state)	—	—	1	μA	3
	IOOL	VOL=V _{SS} (in high-impedance state)	-1	—	—		
Input current 1 (RESET_N) (TEST1_N)	IIH1	VIH1=V _{DD}	—	—	1	μA	4
	IIL1	VIL1=V _{SS}	-600	-300	-2		
Input current 2 (TEST0)	IIH2	VIH2=V _{DD}	2	300	600	μA	4
	IIL2	VIL2=V _{SS}	-1	—	—		
Input current 3 (P00 to P04) (P30 to P35) (P40 to P47) (P50 to P57)	IIH3	VIH3=V _{DD} , V _{DD} =1.8 to 3.6V (when pulled-down)	2	30	200	μA	4
		VIH3=V _{DD} , V _{DD} =1.25 to 3.6V (when pulled-down)	0.01	30	200		
	IIL3	VIL3=V _{SS} , V _{DD} =1.8 to 3.6V (when pulled-up)	-200	-30	-2		
		VIL3=V _{SS} , V _{DD} =1.25 to 3.6V (when pulled-up)	-200	-30	-0.01		
	IIH3Z	VIH3=V _{DD} (in high-impedance state)	—	—	1		
	IIL3Z	VIL3=V _{SS} (in high-impedance state)	-1	—	—		

*1: Characteristics for ML610407.

*2: Characteristics for ML610408.

*3: Characteristics for ML610409.

DC Characteristics (5/5)(V_{DD}=1.25 to 3.6V, V_{SS}=0V, T_a=-20 to +70°C, T_a=-40 to +85°C for P version, unless otherwise specified)

Parameter	Symbol	Condition	Rating			Unit	Measur ement circuit
			Min.	Typ.	Max.		
Input voltage 1 (RESET_N) (TEST0, TEST1_N) (P00 to P04) (P30 to P35) (P40 to P47) (P50 to P57)	VIH1	—	0.7 ×V _{DD}	—	V _{DD}	V	5
	VIL1	V _{DD} =1.8 to 3.6V	0	—	0.3 ×V _{DD}		
		V _{DD} =1.25 to 3.6V	0	—	0.2 ×V _{DD}		
Input pin capacitance (P00 to P04) (P30 to P35) (P40 to P47) (P50 to P57)	CIN	f=10kHz V _{rms} =50mV T _a =25°C	—	—	5	pF	—

Measuring Circuits

Measuring Circuit 1

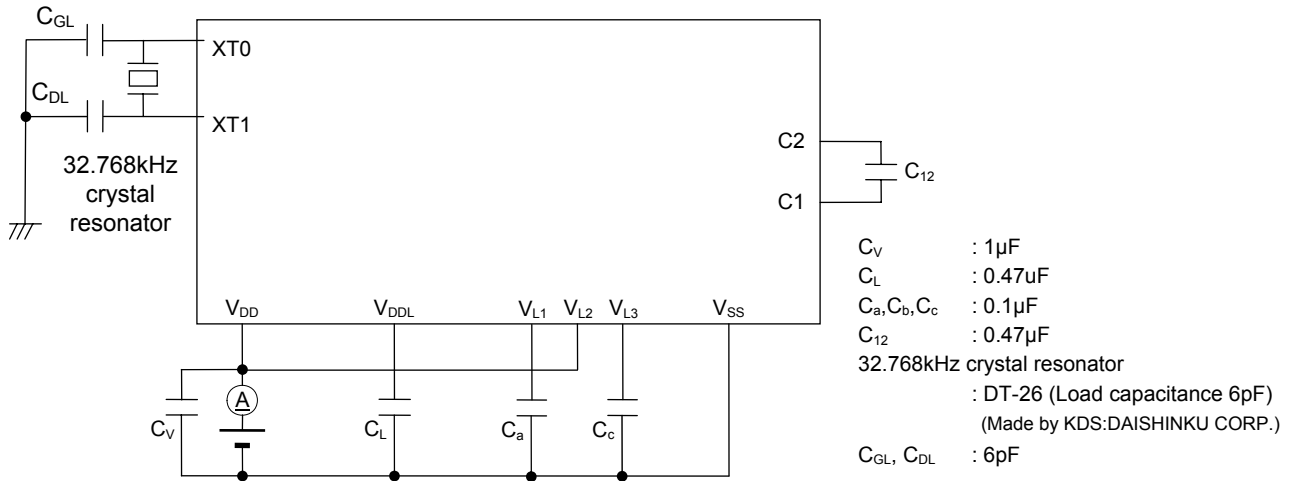

Measuring Circuit 2

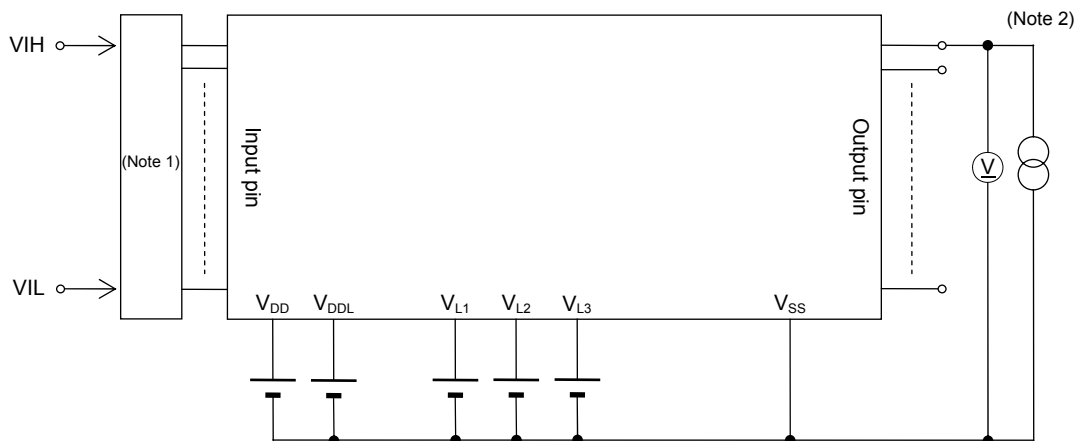

*1: Input logic circuit to determine the specified measuring conditions.
 (Note 2) Repeats for the specified output pin

Measuring Circuit 3

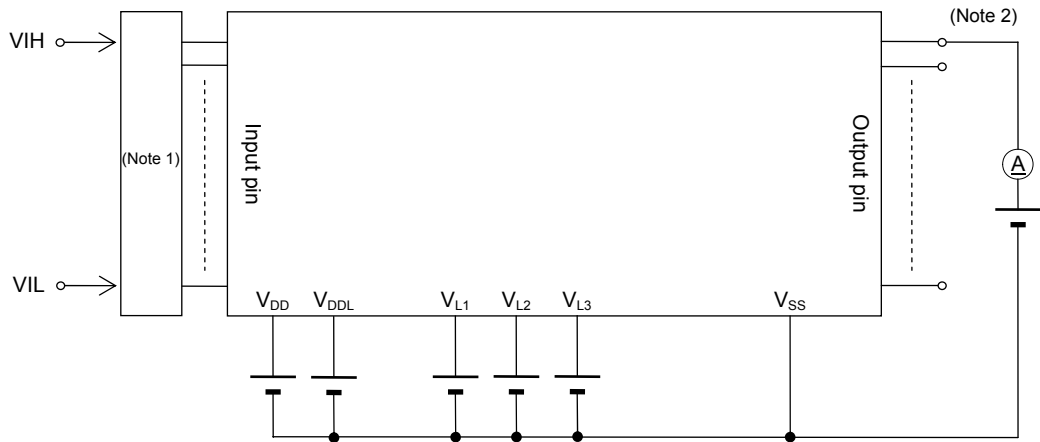

*1: Input logic circuit to determine the specified measuring conditions.
 (Note 2) Repeats for the specified output pin

Measuring Circuit 4

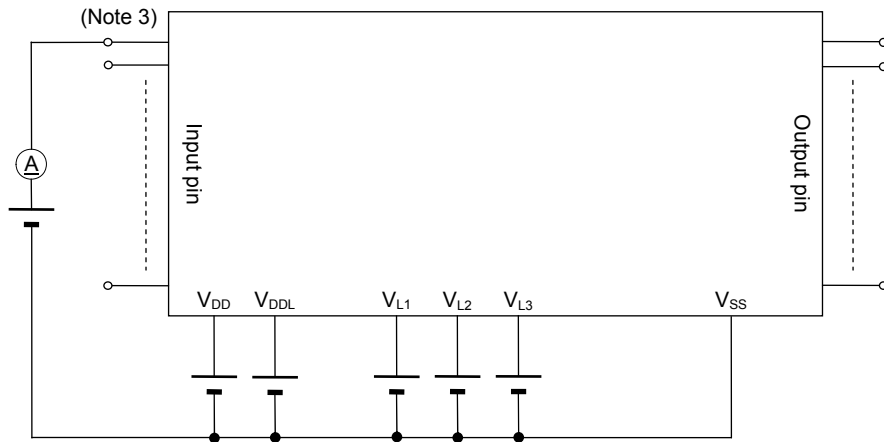

(Note 3) Repeats for the specified input pin

Measuring Circuit 5

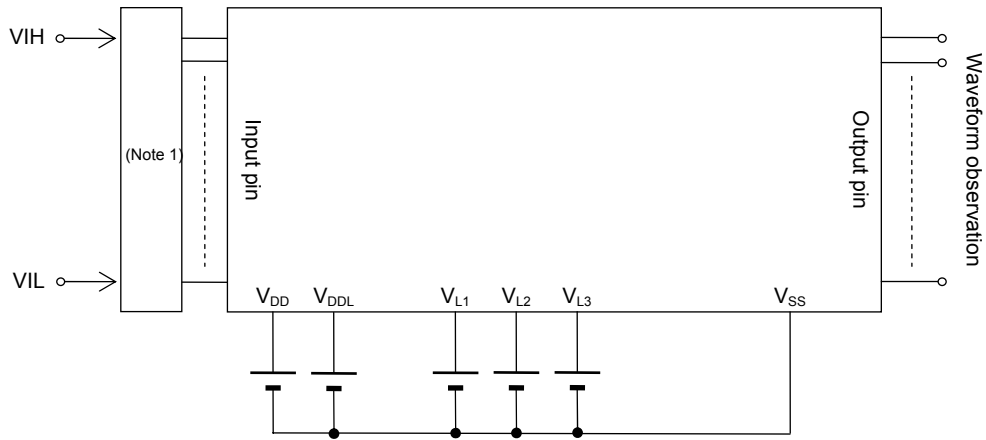

*1: Input logic circuit to determine the specified measuring conditions.

AC Characteristics (External Interrupt)

($V_{DD}=1.25$ to $3.6V$, $V_{SS}=0V$, $T_a=-20$ to $+70^{\circ}C$, $T_a=-40$ to $+85^{\circ}C$ for P version, unless otherwise specified)

Parameter	Symbol	Condition	Rating			Unit
			Min.	Typ.	Max.	
External interrupt disable period	T_{NUL}	Interrupt: Enabled (MIE = 1), CPU: NOP operation System clock: 32.768kHz	76.8	—	106.8	μs

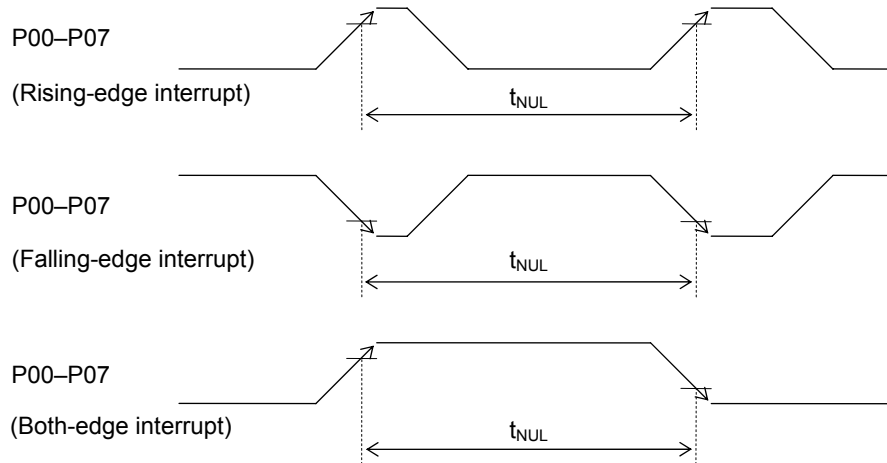

AC Characteristics (UART)(V_{DD}=1.25 to 3.6V, V_{SS}=0V, Ta=-20 to +70°C, Ta=-40 to +85°C for P version, unless otherwise specified)

Parameter	Symbol	Condition	Rating			Unit
			Min.	Typ.	Max.	
Transmit baud rate	t _{TBRT}	—	—	BRT* ¹	—	s
Receive baud rate	t _{RBRT}	—	BRT* ¹ -3%	BRT* ¹	BRT* ¹ +3%	s

*¹: Baud rate period (including the error of the clock frequency selected) set with the UART baud rate register (UA0BRTL,H) and the UART mode register 0 (UA0MOD0).

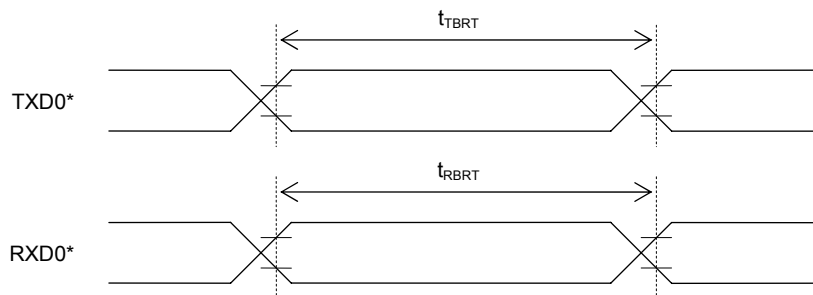

*: Indicates the secondary function of the port.

AC Characteristics (Synchronous Serial Port)

(V_{DD}=1.25 to 3.6V, V_{SS}=0V, T_a=-20 to +70°C, T_a=-40 to +85°C for P version, unless otherwise specified)

Parameter	Symbol	Condition	Rating			Unit
			Min.	Typ.	Max.	
SCLK input cycle (slave mode)	t _{SCYC}	In the 500kHz oscillation mode* ²	10	—	—	μs
		In the 2MHz oscillation mode* ³ V _{DD} =1.8 to 3.6V	1	—	—	μs
SCLK output cycle (master mode)	t _{SCYC}	—	—	SCLK* ¹	—	s
SCLK input pulse width (slave mode)	t _{SW}	In the 500kHz oscillation mode* ²	4	—	—	μs
		In the 2MHz oscillation mode* ³ V _{DD} =1.8 to 3.6V	0.4	—	—	μs
SCLK output pulse width (master mode)	t _{SW}	—	SCLK* ¹ ×0.4	SCLK* ¹ ×0.5	SCLK* ¹ ×0.6	s
SOUT output delay time (slave mode)	t _{SD}	In the 500kHz oscillation mode* ² Output load 10pF	—	—	500	ns
		In the 2MHz oscillation mode* ³ Output load 10pF	—	—	240	
SOUT output delay time (master mode)	t _{SD}	In the 500kHz oscillation mode* ² Output load 10pF	—	—	500	ns
		In the 2MHz oscillation mode* ³ Output load 10pF, V _{DD} =1.8 to 3.6V	—	—	240	
SIN input setup time (slave mode)	t _{SS}	—	80	—	—	ns
SIN input setup time (master mode)	t _{SS}	In the 500kHz oscillation mode* ²	500	—	—	ns
		In the 2MHz oscillation mode* ³ V _{DD} =1.8 to 3.6V	240	—	—	
SIN input hold time	t _{SH}	In the 500kHz oscillation mode* ²	300	—	—	ns
		In the 2MHz oscillation mode* ³ V _{DD} =1.8 to 3.6V	80	—	—	

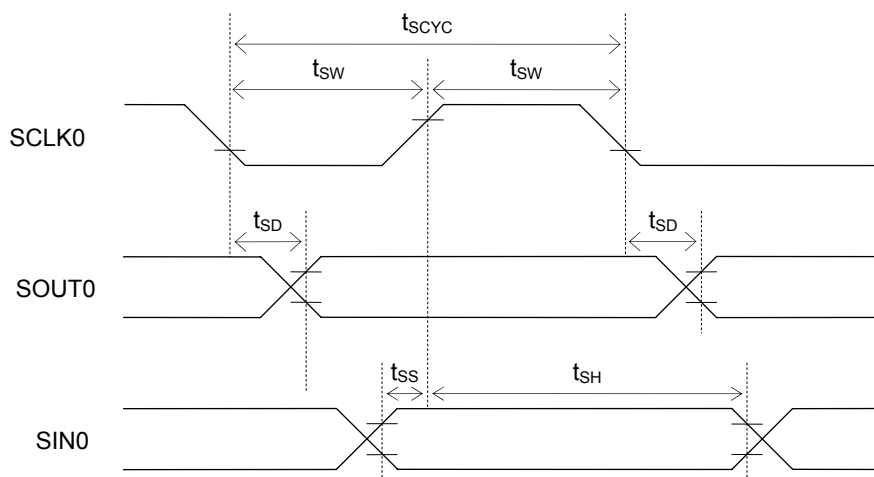
*¹: Clock cycle selected with S0CK3–0 of the serial port 0 mode register (SIO0MOD1)*²: When 500kHz oscillation is selected with RCM of the frequency control register 0 (FCON0)*³: When 2MHz oscillation is selected with RCM of the frequency control register 0 (FCON0)

*: Indicates the secondary function of the port

AC Characteristics (RC Oscillation A/D Converter)

Condition for $V_{DD}=1.8$ to $3.6V$

($V_{DD}=1.8$ to $3.6V$, $V_{SS}=0V$, $T_a=-20$ to $+70^{\circ}C$, $T_a=-40$ to $+85^{\circ}C$ for P version, unless otherwise specified)

Parameter	Symbol	Condition	Rating			Unit
			Min.	Typ.	Max.	
Oscillation resistor	RS0,RS1,RT0, RT0-1,RT1	CS0, CT0, CS1 \geq 740pF	1	—	—	k Ω
Oscillation frequency $V_{DD} = 3.0V$	f_{OSC1}	Resistor for oscillation=1k Ω	457.3	525.2	575.1	kHz
	f_{OSC2}	Resistor for oscillation=10k Ω	53.48	58.18	62.43	kHz
	f_{OSC3}	Resistor for oscillation=100k Ω	5.43	5.89	6.32	kHz
RS to RT oscillation frequency ratio ^{*1} $V_{DD} = 3.0V$	Kf1	RT0, RT0-1, RT1=1k Ω	7.972	9.028	9.782	—
	Kf2	RT0, RT0-1, RT1=10k Ω	0.981	1	1.019	—
	Kf3	RT0, RT0-1, RT1=100k Ω	0.099	0.101	0.104	—

*1: Kfx is the ratio of the oscillation frequency by the sensor resistor to the oscillation frequency by the reference resistor on the same conditions.

$$Kfx = \frac{f_{oscx}(RT0-CS0 \text{ oscillation})}{f_{oscx}(RS0-CS0 \text{ oscillation})}, \frac{f_{oscx}(RT0-1-CS0 \text{ oscillation})}{f_{oscx}(RS0-CS0 \text{ oscillation})}, \frac{f_{oscx}(RT1-CS1 \text{ oscillation})}{f_{oscx}(RS1-CS1 \text{ oscillation})}$$

(x = 1, 2, 3)

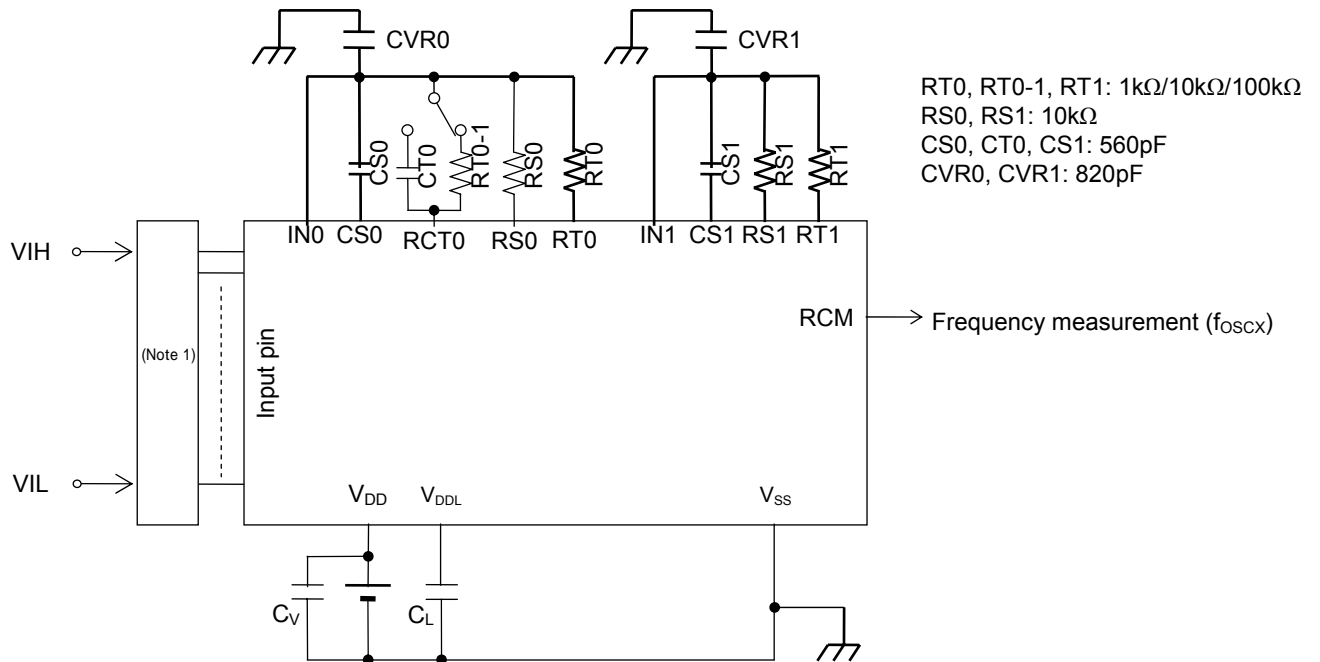

*1: Input logic circuit to determine the specified measuring conditions.

Condition for $V_{DD}=1.25$ to $3.6V$

($V_{DD}=1.25$ to $3.6V$, $V_{SS}=0V$, $T_a=-20$ to $+70^{\circ}C$, $T_a=-40$ to $+85^{\circ}C$ for P version, unless otherwise specified)

Parameter	Symbol	Condition	Rating			Unit
			Min.	Typ.	Max.	
Oscillation resistor	RS0,RS1,RT0, RT0-1,RT1	CS0, CT0, CS1 \geq 740pF	1	—	—	k Ω
Oscillation frequency $V_{DD} = 1.5V$	f_{OSC1}	Resistor for oscillation=6k Ω	81.93	93.16	101.2	kHz
	f_{OSC2}	Resistor for oscillation=15k Ω	35.32	38.75	41.48	kHz
	f_{OSC3}	Resistor for oscillation=105k Ω	5.22	5.65	6.03	kHz
RS to RT oscillation frequency ratio ^{*1} $V_{DD} = 1.5V$	Kf1	RT0, RT0-1, RT1=1k Ω	2.139	2.381	2.632	—
	Kf2	RT0, RT0-1, RT1=10k Ω	0.973	1	1.028	—
	Kf3	RT0, RT0-1, RT1=100k Ω	0.142	0.147	0.152	—
Oscillation frequency $V_{DD} = 3.0V$	f_{OSC1}	Resistor for oscillation=6k Ω	85.28	94.58	103.3	kHz
	f_{OSC2}	Resistor for oscillation=15k Ω	35.72	38.87	41.78	kHz
	f_{OSC3}	Resistor for oscillation=105k Ω	5.189	5.622	6.012	kHz
RS to RT oscillation frequency ratio ^{*1} $V_{DD} = 3.0V$	Kf1	RT0, RT0-1, RT1=1k Ω	2.227	2.432	2.626	—
	Kf2	RT0, RT0-1, RT1=10k Ω	0.982	1	1.018	—
	Kf3	RT0, RT0-1, RT1=100k Ω	0.141	0.145	0.149	—

*1: Kfx is the ratio of the oscillation frequency by the sensor resistor to the oscillation frequency by the reference resistor on the same conditions.

$$Kfx = \frac{f_{oscx}(RT0-CS0 \text{ oscillation})}{f_{oscx}(RS0-CS0 \text{ oscillation})} \quad , \quad \frac{f_{oscx}(RT0-1-CS0 \text{ oscillation})}{f_{oscx}(RS0-CS0 \text{ oscillation})} \quad , \quad \frac{f_{oscx}(RT1-CS1 \text{ oscillation})}{f_{oscx}(RS1-CS1 \text{ oscillation})}$$

(x = 1, 2, 3)

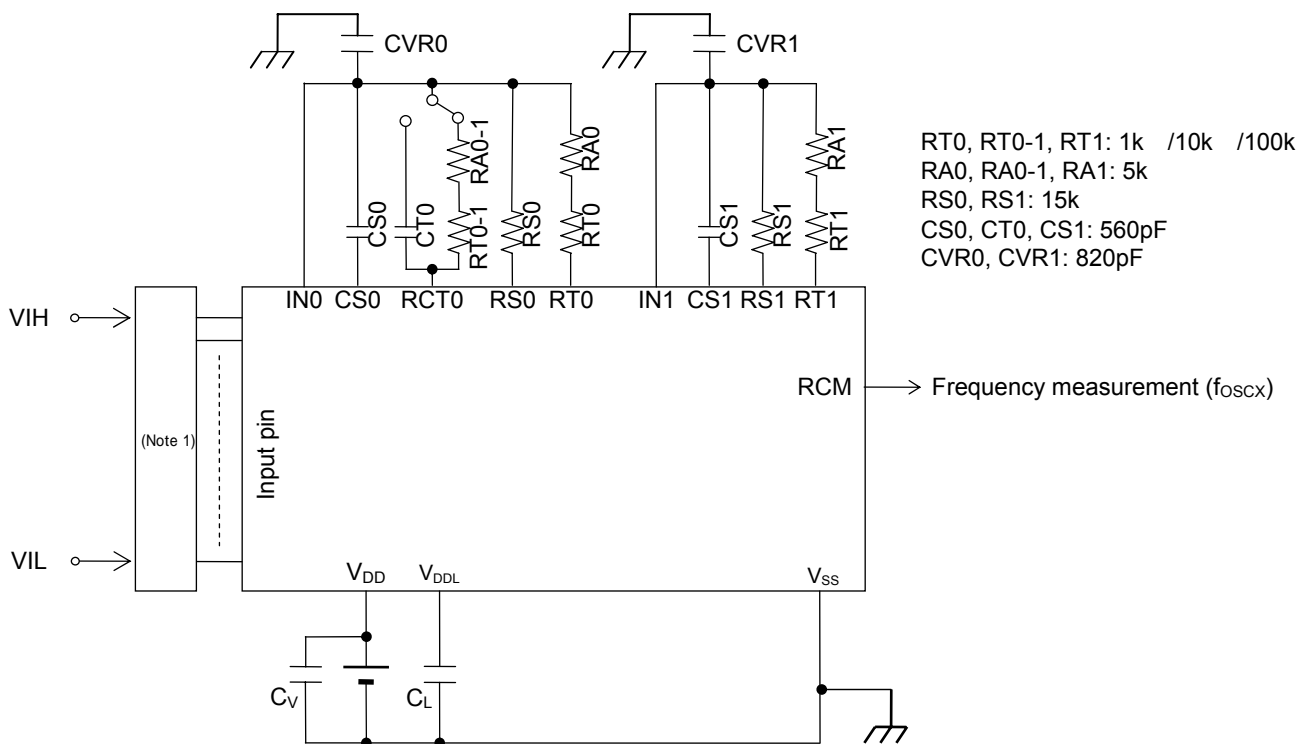

*1: Input logic circuit to determine the specified measuring conditions.

Note:

- Please have the shortest layout for the common node (wiring patterns which are connected to the external capacitors, resistors and IN0/IN1 pin), including CVR0/CVR1. Especially, do not have long wiring between IN0/IN1 and RS0/RS1. The coupling capacitance on the wires may occur incorrect A/D conversion. Also, please do not have signals which may be a source of noise around the node.
- When RT0/RT1 (Thermistor and etc.) requires long wiring due to the restricted placement, please have $V_{SS}(GND)$ trace next to the signal.
- Please make wiring to components (capacitor, resistor, and so on) necessary for objective measurement. Wiring to reserved components may affect to the A/D conversion operation by noise the components itself may have.

PACKAGE DIMENSIONS

(Unit: mm)

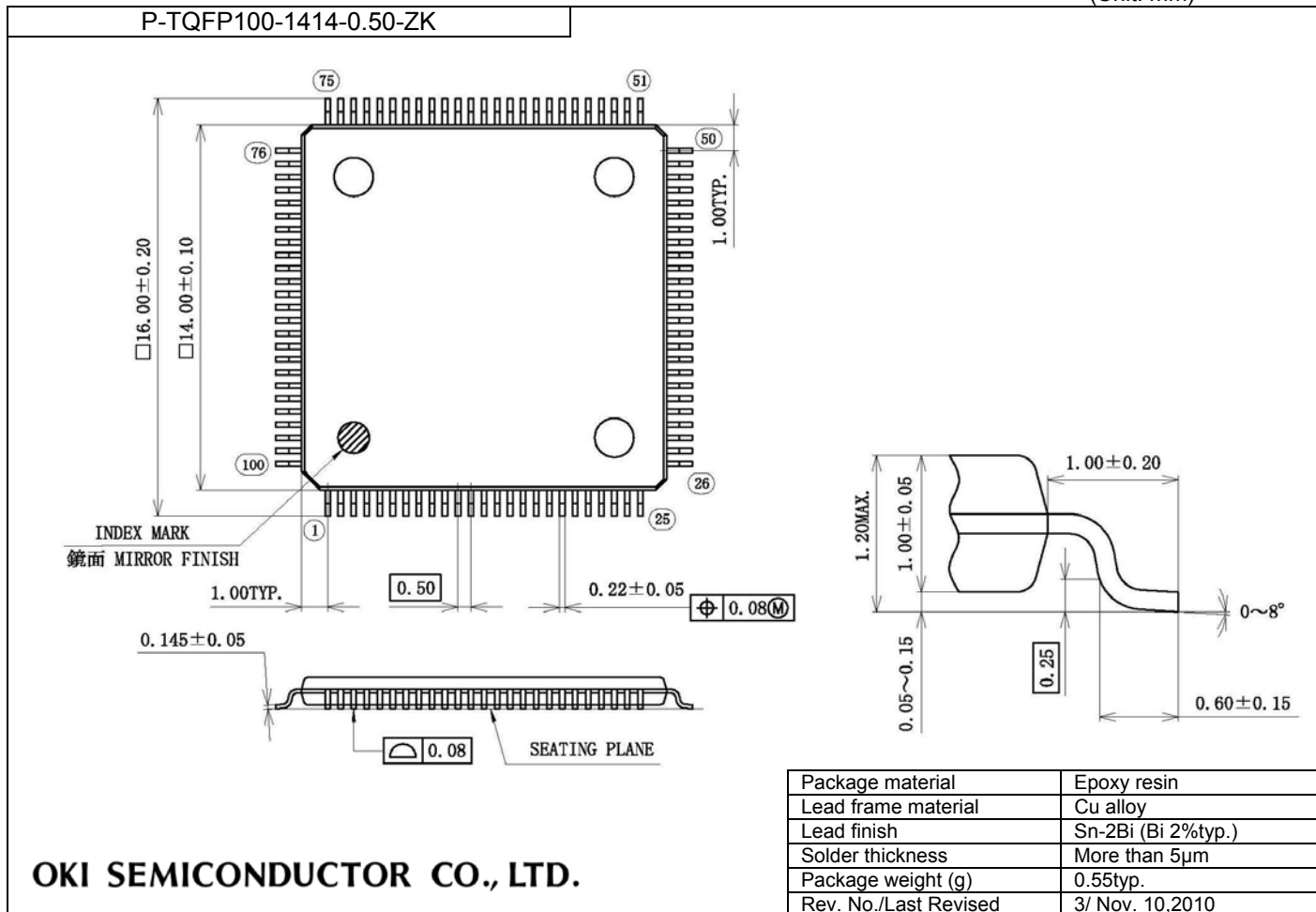

Notes for Mounting the Surface Mount Type Package

The surface mount type packages are very susceptible to heat in reflow mounting and humidity absorbed in storage. Therefore, before you perform reflow mounting, contact our responsible sales person on the product name, package name, pin number, package code and desired mounting conditions (reflow method, temperature and times).

REVISION HISTORY

Document No.	Date	Page		Description
		Previous Edition	Current Edition	
FEDL610409-01	Mar.7,2011	–	–	Formally edition 1
FEDL610409-02	Mar.30,2011	23	23	The supply current was changed.
FEDL610409-02	Mar.30,2011	23	23	Correct the supply current.

NOTICE

1. The information contained herein can change without notice owing to product and/or technical improvements. Before using the product, please make sure that the information being referred to is up-to-date.
2. The outline of action and examples for application circuits described herein have been chosen as an explanation for the standard action and performance of the product. When planning to use the product, please ensure that the external conditions are reflected in the actual circuit, assembly, and program designs.
3. When designing your product, please use our product below the specified maximum ratings and within the specified operating ranges including, but not limited to, operating voltage, power dissipation, and operating temperature.
4. OKI SEMICONDUCTOR assumes no responsibility or liability whatsoever for any failure or unusual or unexpected operation resulting from misuse, neglect, improper installation, repair, alteration or accident, improper handling, or unusual physical or electrical stress including, but not limited to, exposure to parameters beyond the specified maximum ratings or operation outside the specified operating range.
5. Neither indemnity against nor license of a third party's industrial and intellectual property right, etc. is granted by us in connection with the use of the product and/or the information and drawings contained herein. No responsibility is assumed by us for any infringement of a third party's right which may result from the use thereof.
6. The products listed in this document are intended for use in general electronics equipment for commercial applications (e.g., office automation, communication equipment, measurement equipment, consumer electronics, etc.). These products are not, unless specifically authorized by OKI SEMICONDUCTOR authorized for use in any system or application that requires special or enhanced quality and reliability characteristics nor in any system or application where the failure of such system or application may result in the loss or damage of property, or death or injury to humans. Such applications include, but are not limited to, traffic and automotive equipment, safety devices, aerospace equipment, nuclear power control, medical equipment, and life-support systems.
7. Certain products in this document may need government approval before they can be exported to particular countries. The purchaser assumes the responsibility of determining the legality of export of these products and will take appropriate and necessary steps at their own expense for these.
8. No part of the contents contained herein may be reprinted or reproduced without our prior permission.

Copyright 2011 OKI SEMICONDUCTOR CO., LTD.