

HYNIX SEMICONDUCTOR  
8-BIT SINGLE-CHIP MICROCONTROLLERS

# **HMS81004/08/16/24/32E**

# **HMS81020/32TL**

*User's Manual (Ver. 2.01)*



## **REVISION HISTORY**

### **VERSION 2.00 (NOV., 2001)**

1. Modify the maximum supply voltage on page 12.
2. Add the chapter 17 and 18.

### **VERSION 2.01 (MAY., 2002)**

1. Modify the general circuit diagram of HMS81032TL on page 79

---

#### **Version 2.01**

**Published by  
SP MCU Application Team**

**©2001 Hynix Semiconductor, Inc. All right reserved.**

---

Additional information of this manual may be served by Hynix Semiconductor offices in Korea or Distributors and Representatives listed at address directory.

Hynix Semiconductor reserves the right to make changes to any information here in at any time without notice.

The information, diagrams and other data in this manual are correct and reliable; however, Hynix Semiconductor is in no way responsible for any violations of patents or other rights of the third party generated by the use of this manual.

1. OVERVIEW.....	1	14. INTERRUPTS.....	46
Description .....	1	Interrupt priority and sources .....	47
Features .....	1	Interrupt control register .....	47
Development Tools .....	2	Interrupt accept mode .....	48
2. BLOCK DIAGRAM .....	3	Interrupt Sequence .....	49
3. PIN ASSIGNMENT (Top View) .....	4	BRK Interrupt .....	51
4. PACKAGE DIMENSION .....	5	Multi Interrupt .....	51
5. PIN FUNCTION.....	8	External Interrupt .....	51
6. PORT STRUCTURES.....	10	Key Scan Input Processing .....	52
7. ELECTRICAL CHARACTERISTICS ....	12	15. STANDBY FUNCTION .....	54
Absolute Maximum Ratings .....	12	Sleep Mode .....	54
Recommended Operating Conditions .....	12	Stop Mode .....	54
DC Electrical Characteristics .....	12	Standby mode release .....	55
REMOUT Port Ioh Characteristics Graph .....	13	Operation of standby mode release .....	57
REMOUT Port Iol Characteristics Graph .....	14	16. RESET FUNCTION .....	59
AC Characteristics .....	14	External RESET .....	59
8. MEMORY ORGANIZATION.....	16	Power on RESET .....	59
Registers .....	16	Low voltage detection mode .....	61
Program Memory .....	19	17. OVERVIEW OF HMS81032TL .....	64
Data Memory .....	22	Standard Mode pin assignment .....	64
List for Control Registers .....	23	PROM Mode pin assignment .....	65
Addressing Mode .....	25	Standard Mode Pin Description .....	66
9. I/O PORTS .....	29	PROM Mode Pin Description .....	67
R0 Ports .....	29	EPROM Mode .....	68
R1 Ports .....	29	Timing Diagram in EPROM Mode .....	71
R2 Port .....	31	Programming Flow Chart .....	75
10. CLOCK GENERATOR .....	32	REMOUT Port Ioh Characteristics Graph .....	76
Oscillation Circuit .....	33	REMOUT Port Iol Characteristics Graph .....	76
11. BASIC INTERVAL TIMER.....	35	18. GENERAL CIRCUIT DIAGRAM .....	78
12. WATCH DOG TIMER.....	37	General circuit diagram of HMS81032E .....	78
13. Timer0, Timer1, Timer2.....	38	General circuit diagram of HMS81032TL .....	79
		A. MASK ORDER SHEET .....	ii
		B. INSTRUCTION .....	iii
		B.1 Terminology List .....	iii
		B.2 Instruction Map .....	iv
		B.3 Instruction Set .....	v





### 1.3 Development Tools

The HMS81004E/08E/16E/24E/32E are supported by a full-featured macro assembler, an in-circuit emulator CHOICE-Dr.<sup>TM</sup> and OTP programmers. Macro assembler operates under the MS-Windows 95/98<sup>TM</sup> /NT4/W2000.

Please contact sales part of HYNIX

Software	- MS- Window base assembler - Linker / Editor / Debugger
Hardware (Emulator)	- CHOICE-Dr. - CHOICE-Dr. EVA 81C5EVA
OTP programmer	- Universal single programmer. - 4 gang programmer - stand alone

2. BLOCK DIAGRAM

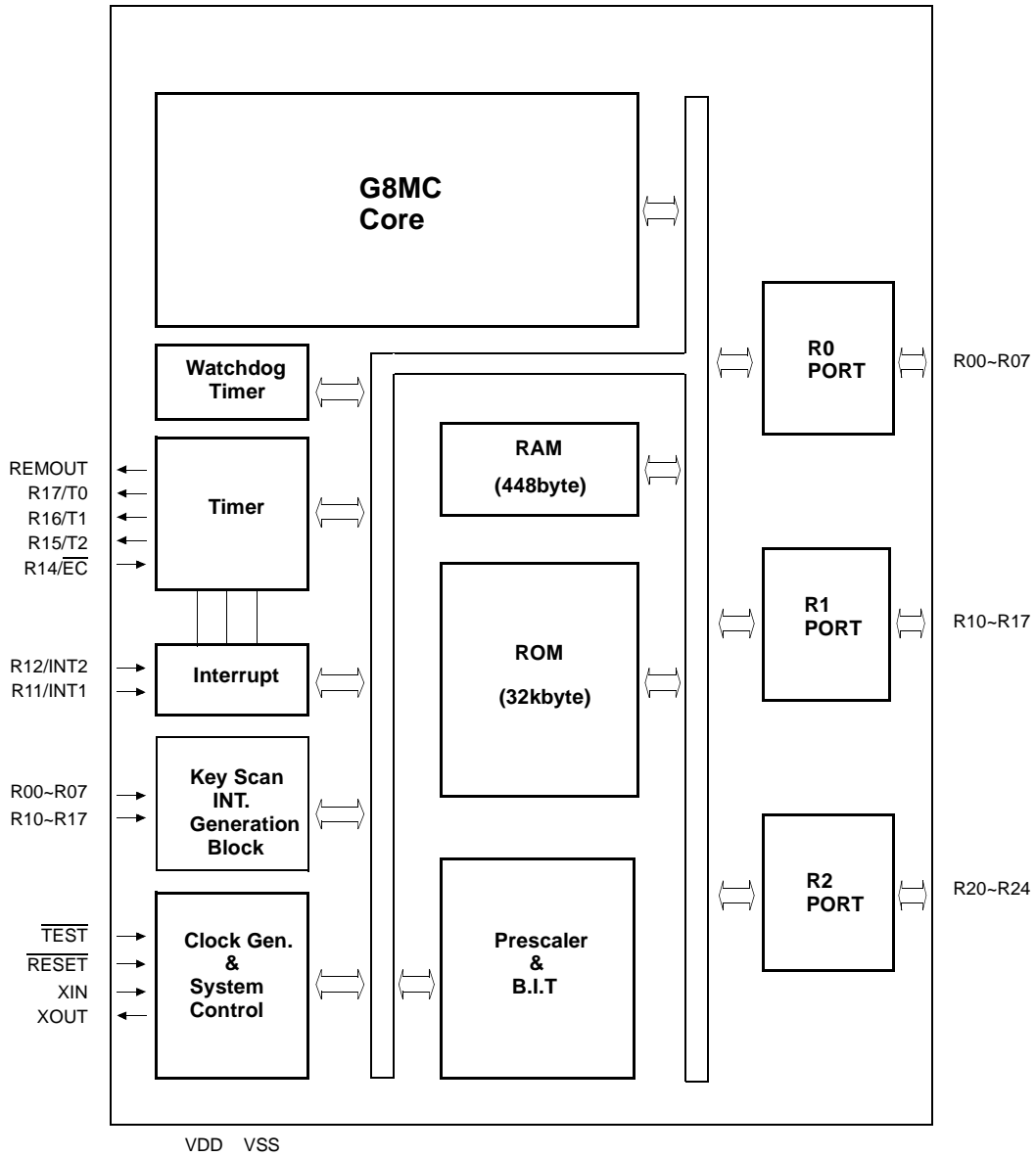

### 3. PIN ASSIGNMENT (Top View)

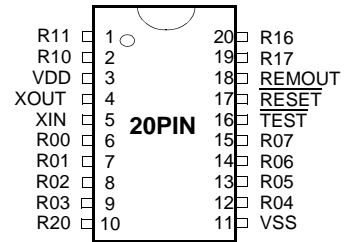
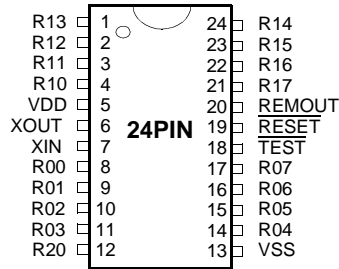
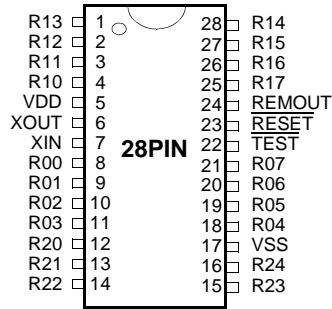

4. PACKAGE DIMENSION

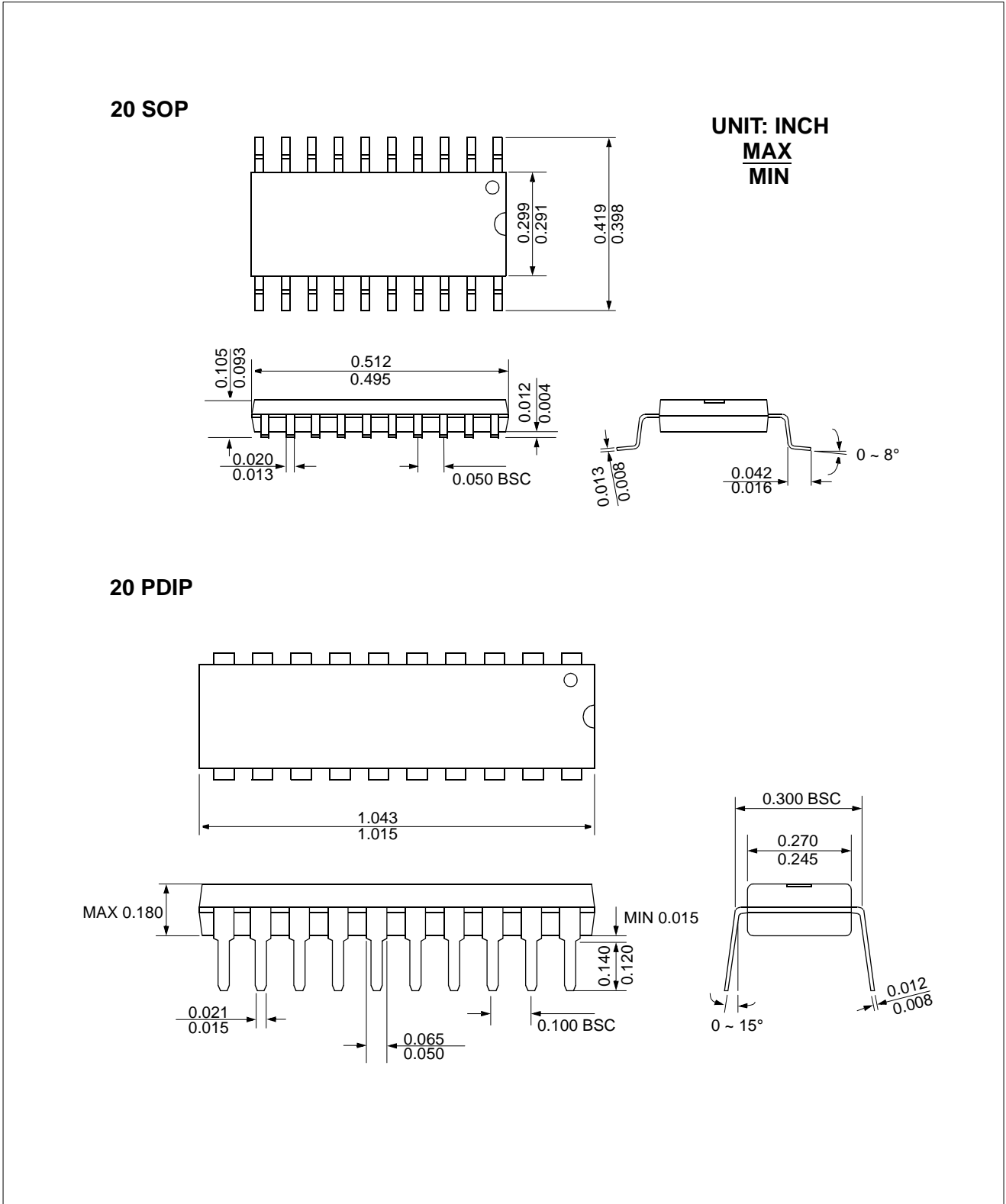

**24 SOP**

**UNIT: INCH**  
**MAX**  
**MIN**

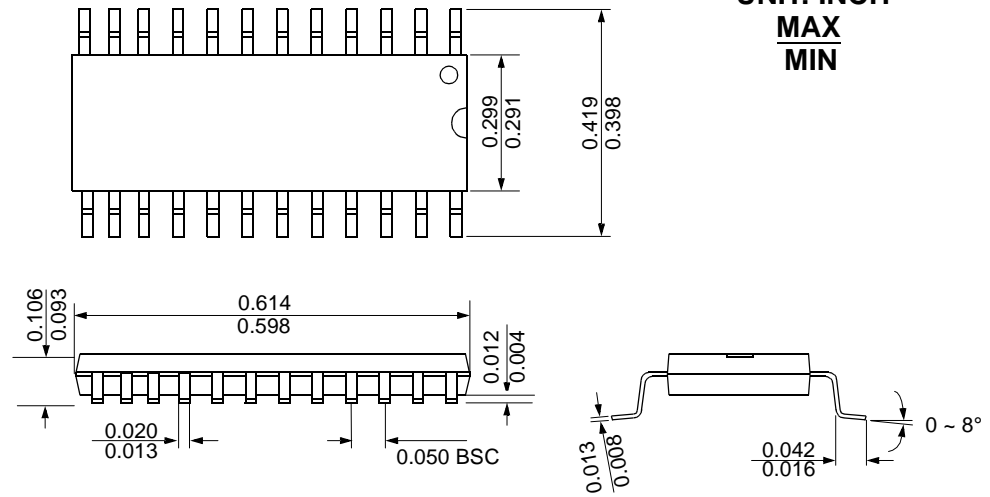

**24 SKDIP**

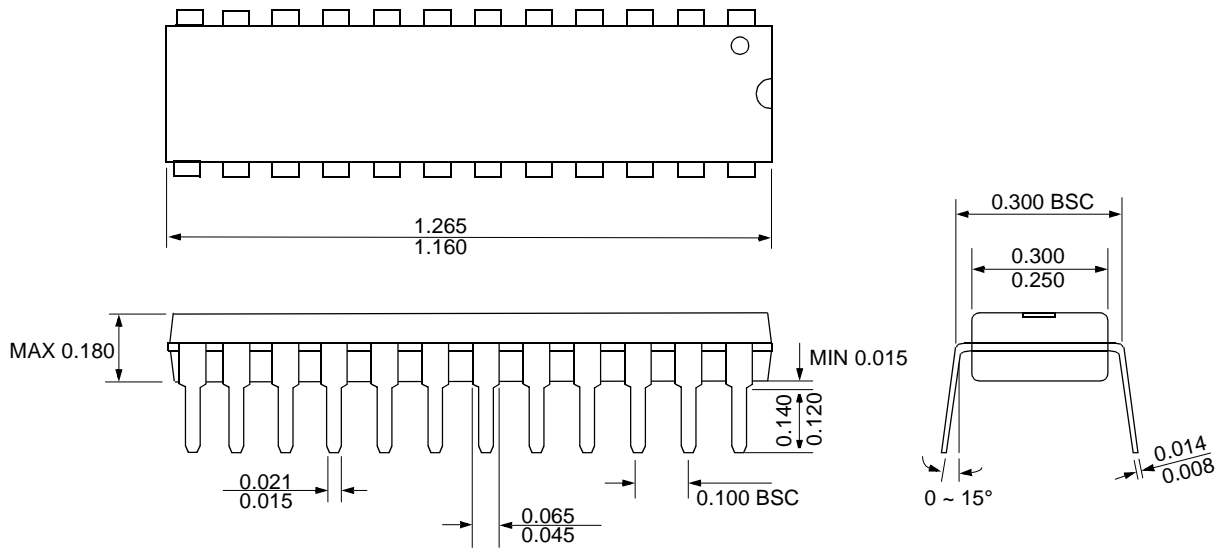

**28 SOP**

**UNIT: INCH**  
**MAX**  
**MIN**

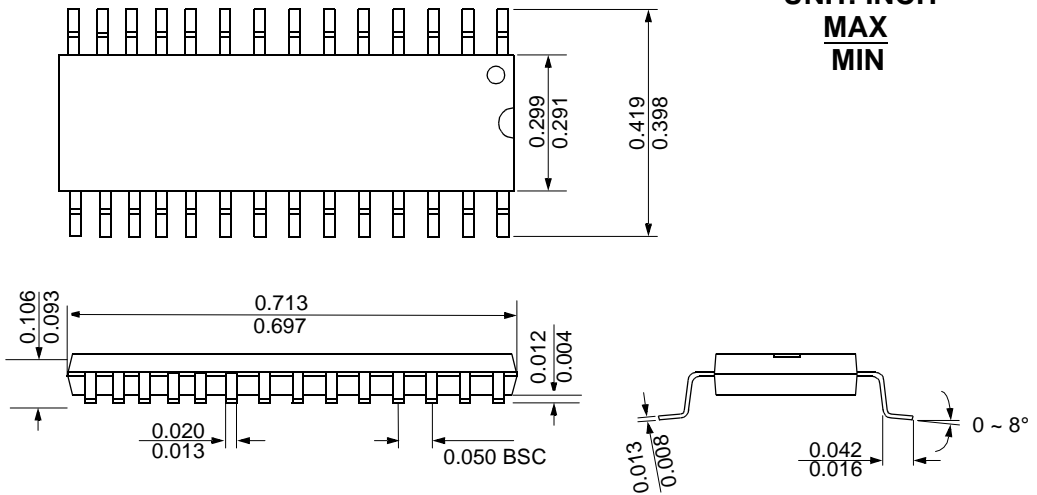

**28 SKDIP**

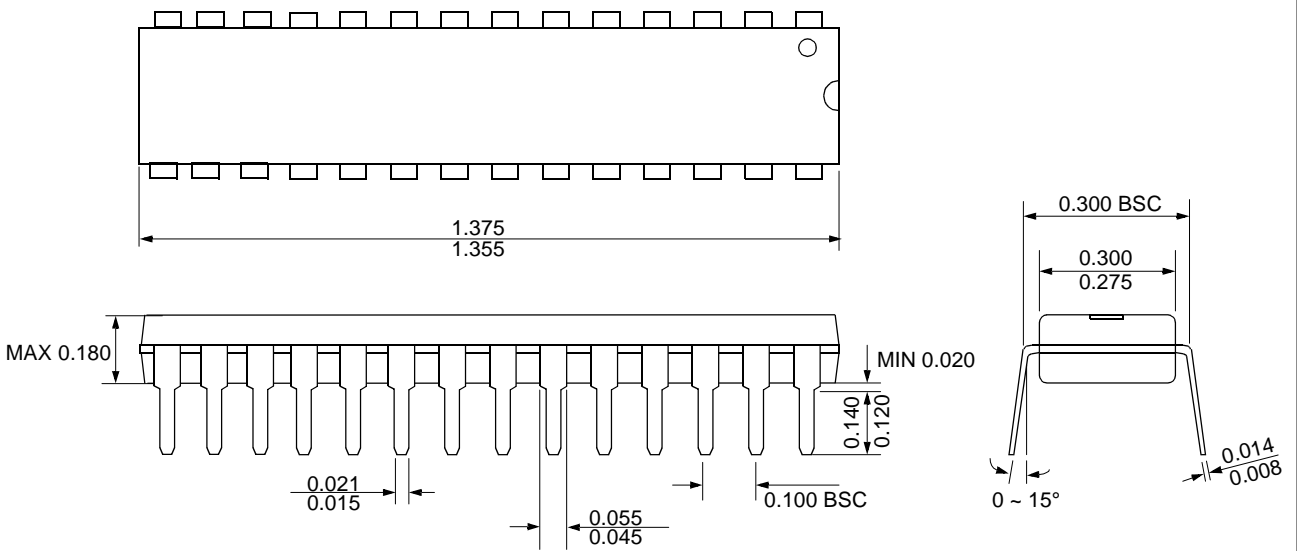

## 5. PIN FUNCTION

**V<sub>DD</sub>**: Supply voltage.

**V<sub>SS</sub>**: Circuit ground.

**TEST**: Used for shipping inspection of the IC. For normal operation, it should be connected to V<sub>DD</sub>.

**RESET**: Reset the MCU.

**X<sub>IN</sub>**: Input to the inverting oscillator amplifier and input to the internal main clock operating circuit.

**X<sub>OUT</sub>**: Output from the inverting oscillator amplifier.

**R00~R07**: R0 is an 8-bit CMOS bidirectional I/O port. R0 pins 1 or 0 written to the Port Direction Register can be used as outputs or inputs.

**R10~R17**: R1 is an 8-bit CMOS bidirectional I/O port. R1 pins 1 or 0 written to the Port Direction Register can be

used as outputs or inputs.

In addition, R1 serves the functions of the various following special features.

Port pin	Alternate function
R11	INT1 (External Interrupt input 1)
R12	INT2 (External Interrupt input 2)
R14	EC (Event Counter input)
R15	T2 (Timer / Counter input 2)
R16	T1 (Timer / Counter input 1)
R17	T0 (Timer / Counter input 0)

**R20~R24**: R2 is an 8-bit CMOS bidirectional I/O port. R2 pins 1 or 0 written to the Port Direction Register can be used as outputs or inputs.

PIN NAME	INPUT/ OUTPUT	Function	@RESET	@STOP
R00	I/O	- Each bit of the port can be individually configured as an input or an output by user software - Push-pull output - CMOS input with pull-up resistor (option) - Can be programmable as key scan input - Pull-up resistors are automatically disabled at output mode	INPUT	State of before Stop
R01	I/O			
R02	I/O			
R03	I/O			
R04	I/O			
R05	I/O			
R06	I/O			
R07	I/O			
R10	I/O	- Each bit of the port can be individually configured as an input or an output by user software - Push-pull output - CMOS input with pull-up resistor (option) - Can be programmable as key scan input or open drain output - Pull-up resistors are automatically disabled at output mode - Direct driving of LED(N-Tr.)	INPUT	State of before Stop
R11/INT1	I/O			
R12/INT2	I/O			
R13	I/O			
R14/ $\overline{EC}$	I/O			
R15/T2	I/O			
R16/T1	I/O			
R17/T0	I/O			
R20	I/O	- Each bit of the port can be individually configured as an input or an output by user software - Push-pull output - CMOS input with pull-up resistor (option) - Pull-up resistors are automatically disabled at output mode - Direct driving of LED(N-Tr.)	INPUT	State of before Stop
R21	I/O			
R22	I/O			
R23	I/O			
R24	I/O			
XIN	I	Oscillator input		Low
XOUT	O	Oscillator output		High
REMOUT	O	High current output	'L' output	'L' output
$\overline{RESET}$	I	Includes pull-up resistor	'L' level	state of before stop
$\overline{TEST}$	I	Includes pull-up resistor		
VDD	P	Positive power supply		
VSS	P	Ground		

## 6. PORT STRUCTURES

### R0[0:7]

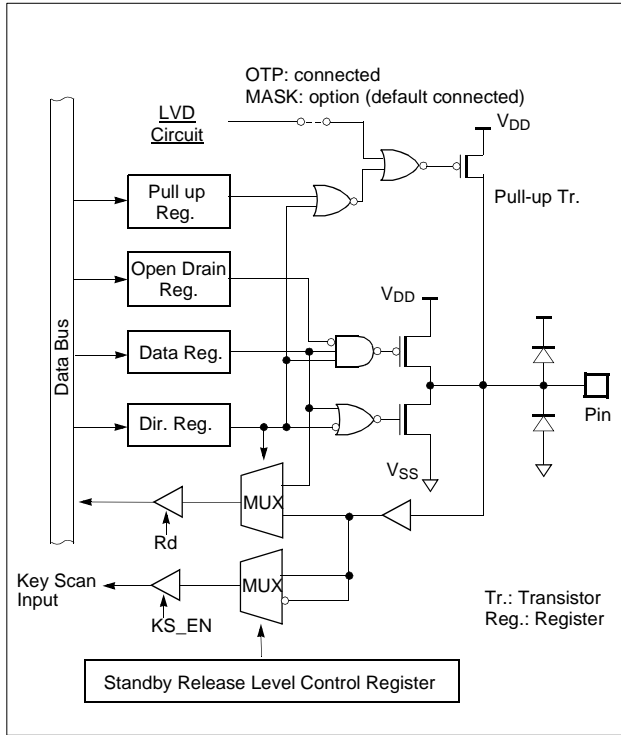

### R11/INT1, R12/INT2, R14/ $\overline{EC}$

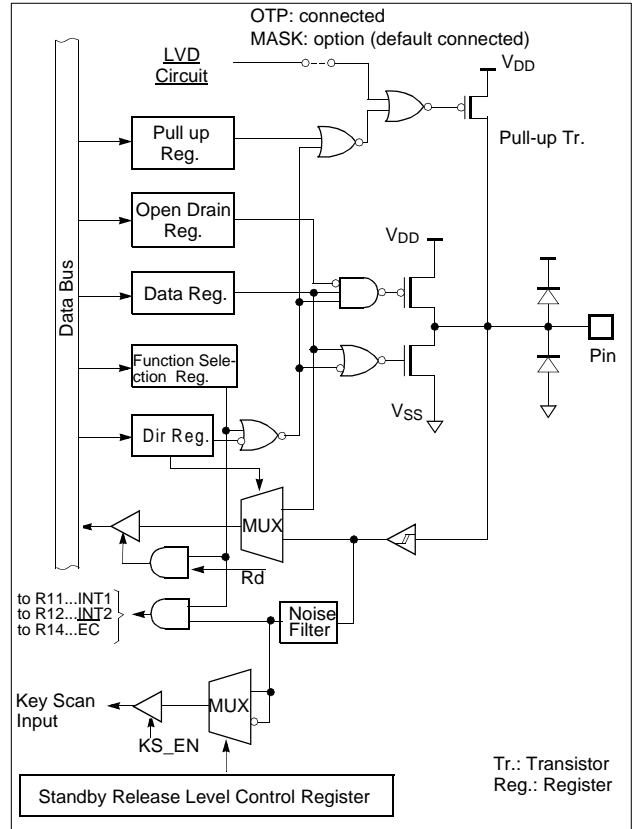

### R10, R13

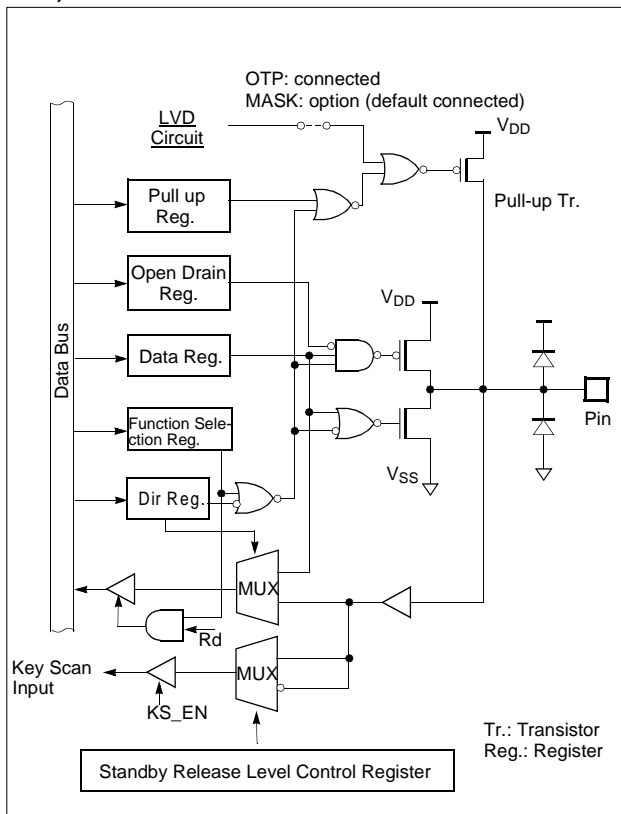

**R15/T2, R16/T1, R17/T0**

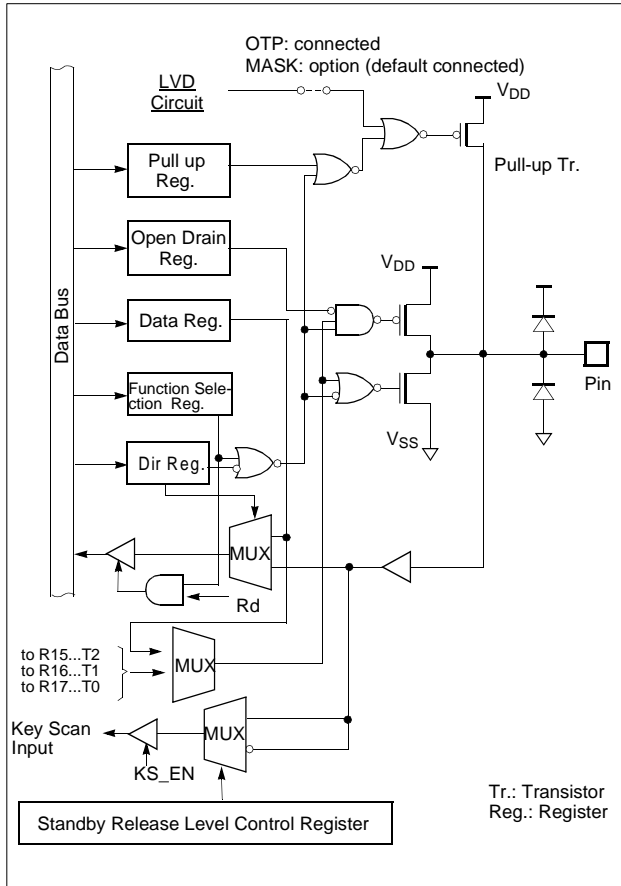

**R2[0:4]**

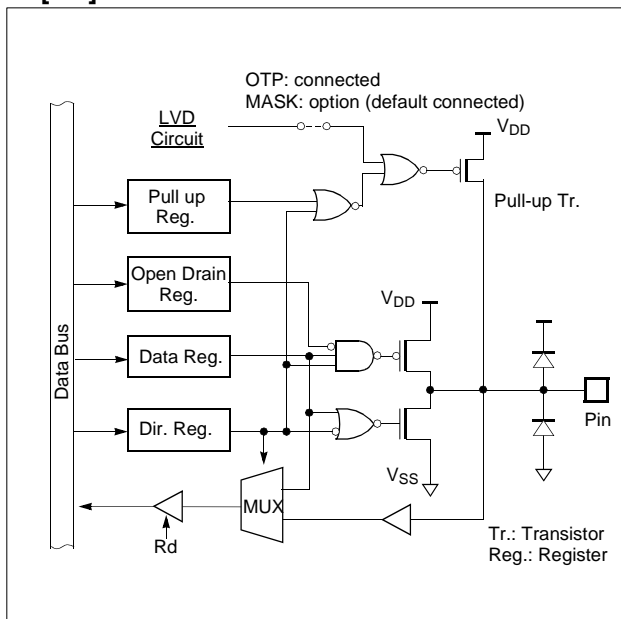

**TEST**

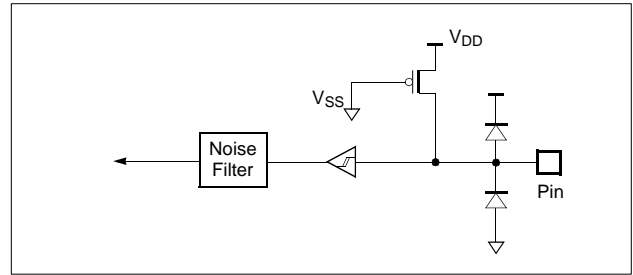

**REMOUT**

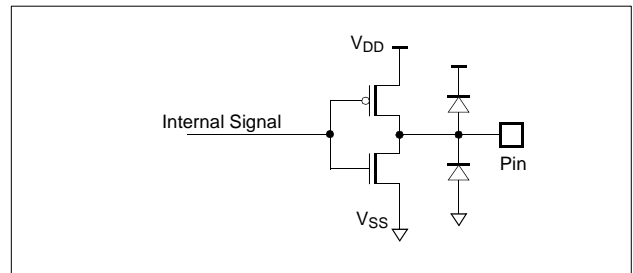

**XIN, XOUT**

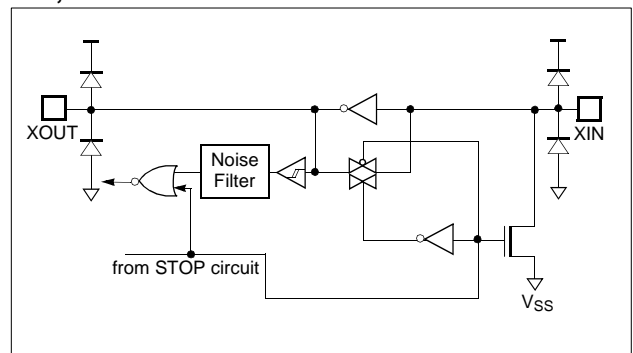

**RESET**

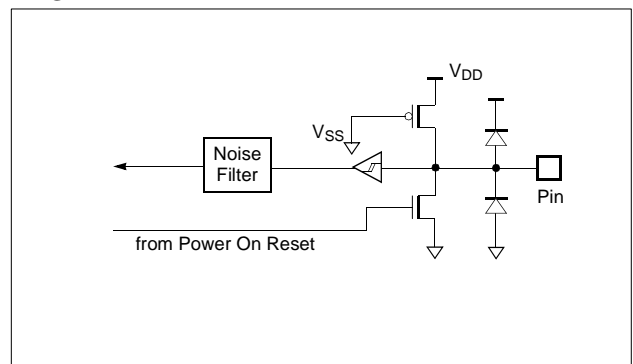

## 7. ELECTRICAL CHARACTERISTICS

### 7.1 Absolute Maximum Ratings

Supply voltage .....	-0.3 to +4.1 V
Input Voltage .....	-0.3 to $V_{DD}+0.3$ V
Output Voltage .....	-0.3 to $V_{DD}+0.3$ V
Operating Temperature.....	0~70°C
Storage Temperature .....	-65~150°C
Power Dissipation.....	700 mA

**Note:** Stresses above those listed under “Absolute Maximum Ratings” may cause permanent damage to the device. This is a stress rating only and functional operation of the device at any other conditions above those indicated in the operational sections of this specification is not implied. Exposure to absolute maximum rating conditions for extended periods may affect device reliability.

### 7.2 Recommended Operating Conditions

Parameter	Symbol	Condition	Specifications		Unit
			Min.	Max.	
Supply Voltage	$V_{DD}$	$f_{XIN}=4\text{MHz}$	2.0	3.6	V
Operating Frequency	$f_{XIN}$	$V_{DD}=2.0\sim 3.6\text{V}$	1.0	4.0	MHz
Operating Temperature	$T_{OPR}$	-	0	+70	°C

### 7.3 DC Electrical Characteristics

( $T_A=0\sim 70^\circ\text{C}$ ,  $V_{DD}=2.0\sim 3.6\text{V}$ ,  $\text{GND}=0\text{V}$ )

Parameter	Symbol	Condition	Specifications			Unit
			Min.	Typ.	Max.	
High level input Voltage	$V_{IH1}$	R11,R12,R14, $\overline{\text{RESET}}$	$0.8 V_{DD}$	-	$V_{DD}$	V
	$V_{IH2}$	R0,R1(except R11,R12,R14), R2	$0.7 V_{DD}$	-	$V_{DD}$	V
Low level input Voltage	$V_{IL1}$	R11,R12,R14, $\overline{\text{RESET}}$	0	-	$0.2 V_{DD}$	V
	$V_{IL2}$	R0,R1(except R11,R12,R14), R2	0	-	$0.3 V_{DD}$	V
High level input Leakage Current	$I_{IH}$	R0,R1,R2, $\overline{\text{RESET}}$ , $V_{IH}=V_{DD}$	-	-	1	$\mu\text{A}$
Low level input Leakage Current	$I_{IL}$	R0,R1,R2, $\overline{\text{RESET}}$ (without pull-up), $V_{IL}=0$	-	-	-1	$\mu\text{A}$
High level output Voltage	$V_{OH1}$	R0, $I_{OH}=-0.5\text{mA}$	$V_{DD}-0.4$	-	-	V
	$V_{OH2}$	R1, R2, $I_{OH}=-1.0\text{mA}$	$V_{DD}-0.4$	-	-	V
	$V_{OH3}$	XIN, XOUT, $I_{OH}=-200\mu\text{A}$	$V_{DD}-0.9$	-	-	V
Low level output Voltage	$V_{OL1}$	R0, $I_{OL}=1\text{mA}$	-	-	0.4	V
	$V_{OL2}$	R1, R2, $I_{OL}=5\text{mA}$	-	-	0.8	V
	$V_{OL3}$	XIN, XOUT, $I_{OL}=200\mu\text{A}$	-	-	0.8	V
High level output Leakage Current	$I_{OHL}$	R0,R1,R2, $V_{OH}=V_{DD}$	-	-	1	$\mu\text{A}$
Low level output Leakage Current	$I_{OLL}$	R0,R1,R2, $V_{OL}=0$	-	-	-1	$\mu\text{A}$

Parameter	Symbol	Condition	Specifications			Unit
			Min.	Typ.	Max.	
High Level output current	$I_{OH}$	REMOUT, $V_{OH} = 2V$	-30	-12	-5	mA
Low Level output current	$I_{OL}$	REMOUT, $V_{OL} = 1V$	0.5	-	3	mA
Input pull-up current	$I_p$	R0,R1,R2, $\overline{RESET}$ , $VDD=3V$	15	30	60	$\mu A$
Power Supply Current	$I_{DD1}$	Operating current, $f_{xin}=4Mhz$ , $VDD=2.0V$	-	2.4	6	mA
	$I_{DD2}$	Operating current, $f_{xin}=4Mhz$ , $VDD=3.6V$	-	4	10	mA
	$I_{SLP1}$	Sleep mode current, $f_{xin}=4Mhz$ , $VDD=2.0V$	-	1	2	mA
	$I_{SLP2}$	Sleep mode current, $f_{xin}=4Mhz$ , $VDD=3.6V$	-	2	3	mA
	$I_{STP1}$	Stop mode current, Oscillator Stop $VDD=2.0V$	-	2	8	$\mu A$
	$I_{STP2}$	Stop mode current, Oscillator Stop $VDD=3.6V$	-	3	10	$\mu A$
RAM retention supply voltage	$V_{RET}$	-	0.7	-	-	V

### 7.4 REMOUT Port Ioh Characteristics Graph

(typical process & room temperature)

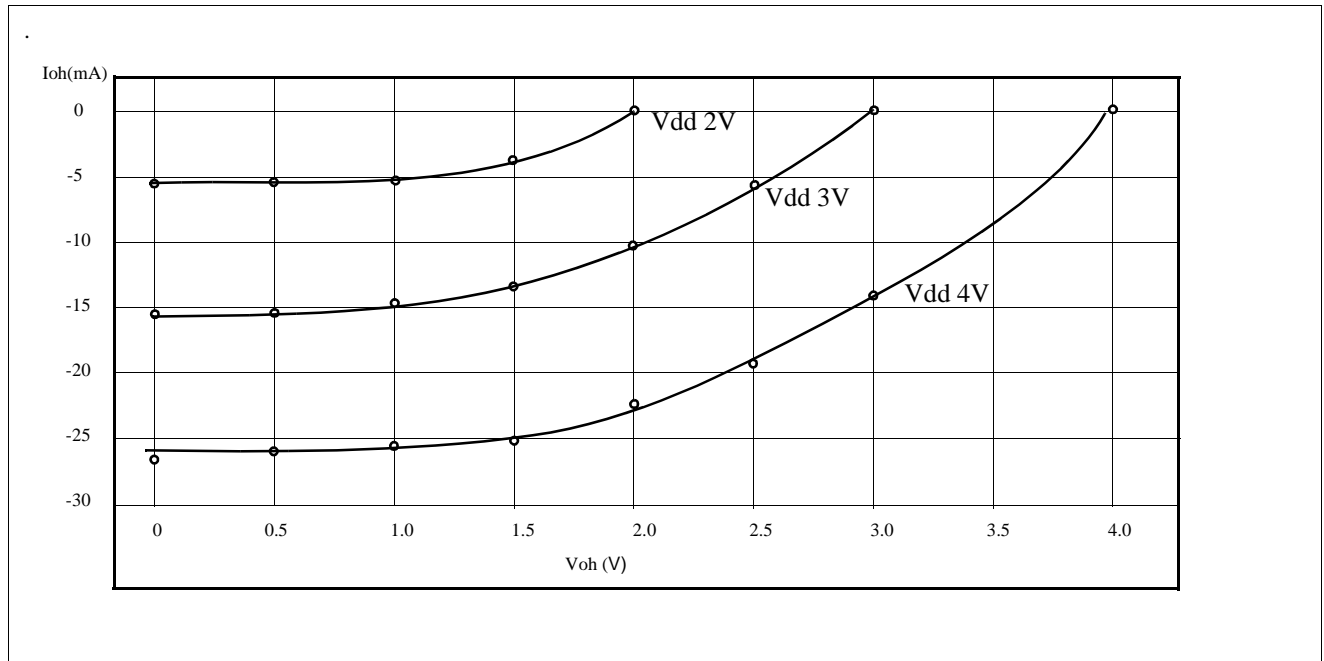

Figure 7-1 Ioh vs Voh

## 7.5 REMOUT Port Iol Characteristics Graph

(typical process & room temperature)

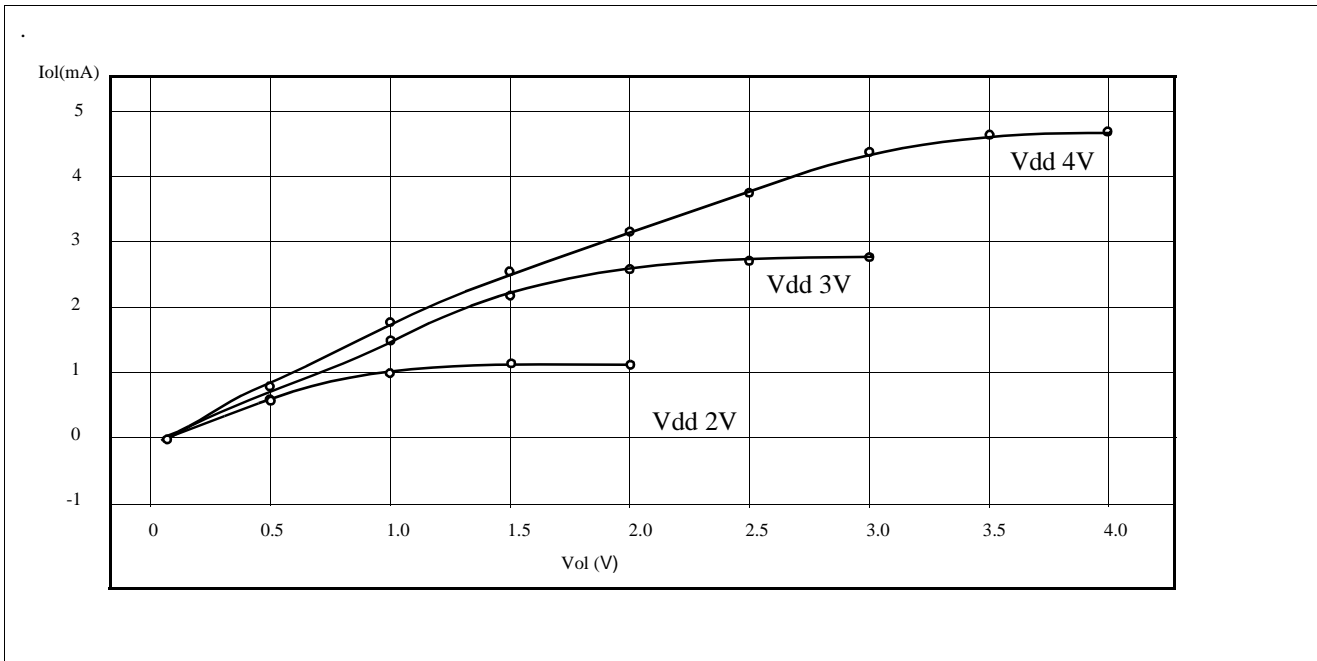

Figure 7-2 Iol vs Vol

## 7.6 AC Characteristics

( $T_A=0\sim+70^\circ\text{C}$ ,  $V_{DD}=2.0\sim3.6\text{V}$ ,  $V_{SS}=0\text{V}$ )

Parameter	Symbol	Pins	Specifications			Unit
			Min.	Typ.	Max.	
External clock input cycle time	$t_{CP}$	$X_{IN}$	250	500	1000	ns
System clock cycle time	$t_{SYS}$		500	1000	2000	ns
External clock pulse width High	$t_{CPH}$	$X_{IN}$	40	-	-	ns
External clock pulse width Low	$t_{CPL}$	$X_{IN}$	40	-	-	ns
External clock rising time	$t_{RCP}$	$X_{IN}$	-	-	40	ns
External clock falling time	$t_{FCP}$	$X_{IN}$	-	-	40	ns
Interrupt pulse width High	$t_{IH}$	INT1, INT2	2	-	-	$t_{SYS}$
Interrupt pulse width Low	$t_{IL}$	INT1, INT2	2	-	-	$t_{SYS}$
$\overline{\text{RESET}}$ Input pulse width low	$t_{RSTL}$	$\overline{\text{RESET}}$	8	-	-	$t_{SYS}$
Event counter input pulse width high	$t_{ECH}$	$\overline{\text{EC}}$	2	-	-	$t_{SYS}$
Event counter input pulse width low	$t_{ECL}$	$\overline{\text{EC}}$	2	-	-	$t_{SYS}$
Event counter input pulse rising time	$t_{REC}$	$\overline{\text{EC}}$	-	-	40	ns
Event counter input pulse falling time	$t_{FEC}$	$\overline{\text{EC}}$	-	-	40	ns

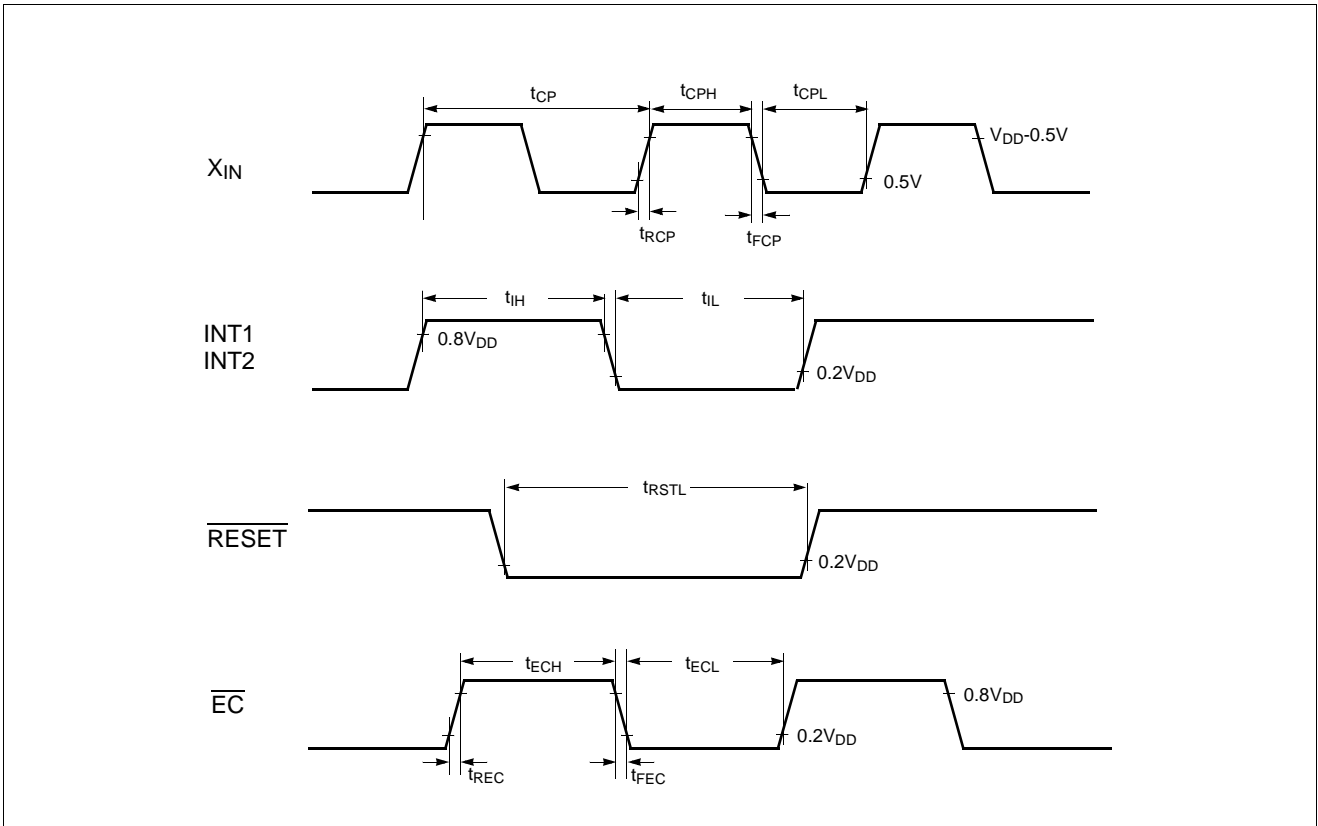

Figure 7-3 Timing Diagram

## 8. MEMORY ORGANIZATION

The HMS81004E/08E/16E/24E/32E has separate address spaces for Program memory and Data Memory. Program memory can only be read, not written to. It can be up to

32K bytes of Program memory. Data memory can be read and written to up to 448 bytes including the stack area.

### 8.1 Registers

This device has six registers that are the Program Counter (PC), an Accumulator (A), two index registers (X, Y), the Stack Pointer (SP), and the Program Status Word (PSW). The Program Counter consists of 16-bit register.

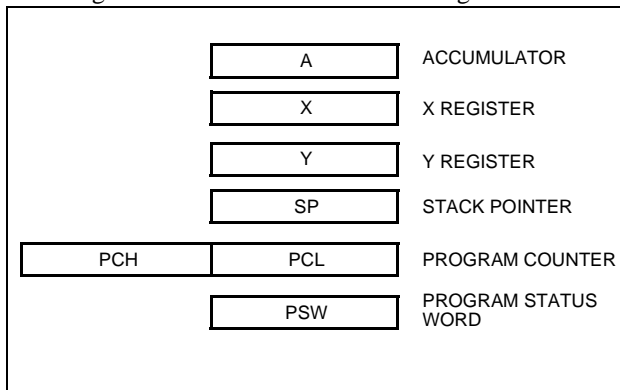

Figure 8-1 Configuration of Registers

#### Accumulator:

The Accumulator is the 8-bit general purpose register, used for data operation such as transfer, temporary saving, and conditional judgement, etc. The Accumulator can be used as a 16-bit register with Y Register as shown below.

In the case of multiplication instruction, execute as a multiplier register. After multiplication operation, the lower 8-bit of the result enters. ( $Y * A \Rightarrow YA$ ). In the case of division instruction, execute as the lower 8-bit of dividend. After division operation, quotient enters.

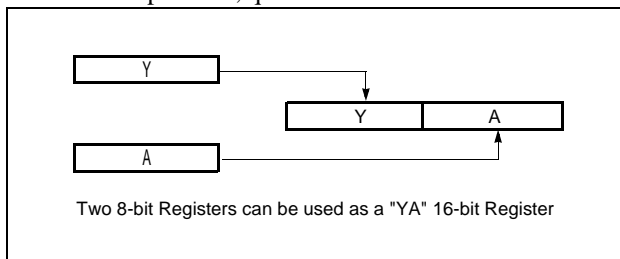

Figure 8-2 Configuration of YA 16-bit Register

#### X, Y Registers:

In the addressing mode which uses these index registers,

the register contents are added to the specified address, which becomes the actual address. These modes are extremely effective for referencing subroutine tables and memory tables. The index registers also have increment, decrement, comparison and data transfer functions, and they can be used as simple accumulators.

#### • X Register

In the case of division instruction, execute as register.

#### • Y Register

In the case of 16-bit operation instruction, execute as the upper 8-bit of YA. (16-bit accumulator). In the case of multiplication instruction, execute as a multiplicand register. After multiplication operation, the upper 8-bit of the result enters. In the case of division instruction, execute as the upper 8-bit of dividend. After division operation, remains enters. Y register can be used as loop counter of conditional branch command. (e.g.DBNE Y, rel)

#### Stack Pointer:

The Stack Pointer is an 8-bit register used for occurrence interrupts, calling out subroutines and PUSH, POP, RETI, RET instruction. Stack Pointer identifies the location in the stack to be accessed (save or restore).

Generally, SP is automatically updated when a subroutine call is executed or an interrupt is accepted. However, if it is used in excess of the stack area permitted by the data memory allocating configuration, the user-processed data may be lost. The SP is post-decremented when a subroutine call or a push instruction is executed, or when an interrupt is accepted. The SP is pre-incremented when a return or a pop instruction is executed.

The stack can be located at any position within 100<sub>H</sub> to 1FF<sub>H</sub> of the internal data memory. The SP is not initialized by hardware, requiring to write the initial value (the location with which the use of the stack starts) by using the initialization routine. Normally, the initial value of "FF<sub>H</sub>" is used.

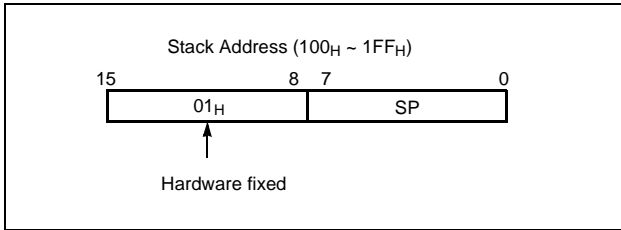

**Caution:**

*The Stack Pointer must be initialized by software because its value is undefined after RESET.*

Example: To initialize the SP

```
LDX    #0FFH
TXSP           ; SP ← FFH
```

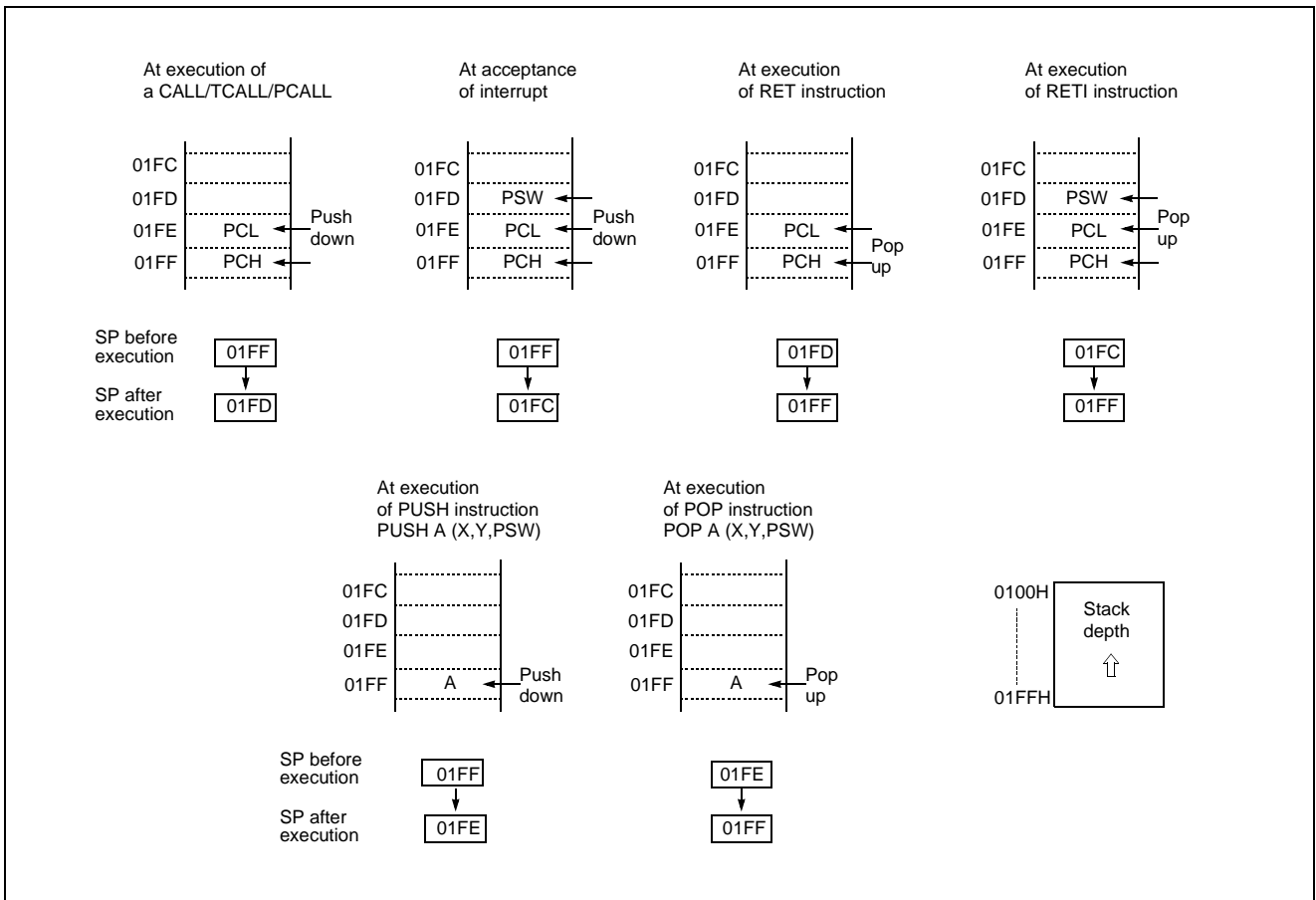

Figure 8-3 Stack Operation

**Program Counter:**

The Program Counter is a 16-bit wide which consists of two 8-bit registers, PCH and PCL. This counter indicates the address of the next instruction to be executed. In reset state, the program counter has reset routine address (PCH:0FF<sub>H</sub>, PCL:0FE<sub>H</sub>).

**Program Status Word:**

The Program Status Word (PSW) contains several bits that

reflect the current state of the CPU. The PSW is described in Figure 8-4. It contains the Negative flag, the Overflow flag, the Break flag the Half Carry (for BCD operation), the Interrupt enable flag, the Zero flag, and the Carry flag.

**[Carry flag C]**

This flag stores any carry or borrow from the ALU of CPU after an arithmetic operation and is also changed by the Shift Instruction or Rotate Instruction.

**[Zero flag Z]**

This flag is set when the result of an arithmetic operation or data transfer is "0" and is cleared by any other result.

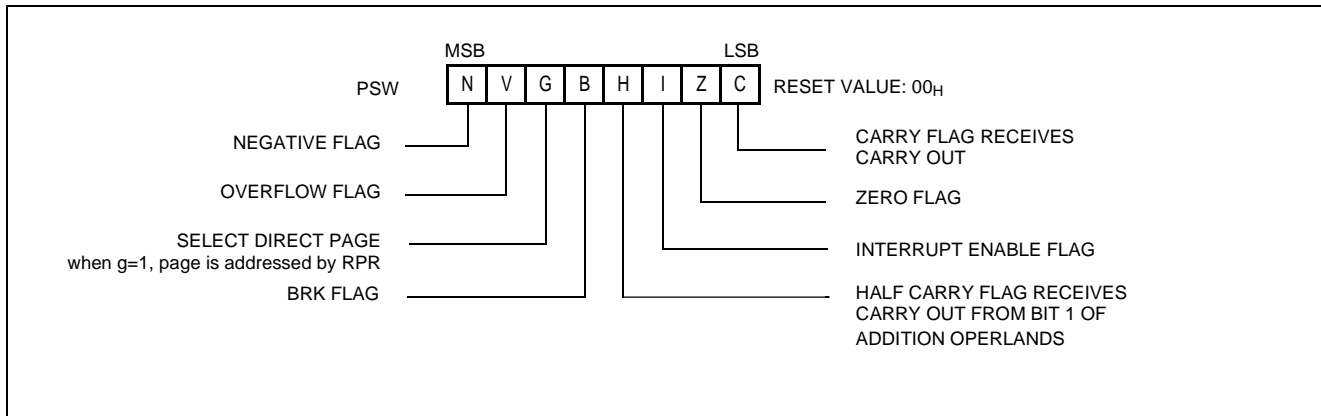

Figure 8-4 PSW (Program Status Word) Register

**[Interrupt disable flag I]**

This flag enables/disables all interrupts except interrupt caused by Reset or software BRK instruction. All interrupts are disabled when cleared to "0". This flag immediately becomes "0" when an interrupt is served. It is set by the EI instruction and cleared by the DI instruction.

**[Half carry flag H]**

After operation, this is set when there is a carry from bit 3 of ALU or there is no borrow from bit 4 of ALU. This bit can not be set or cleared except CLRV instruction with Overflow flag (V).

**[Break flag B]**

This flag is set by software BRK instruction to distinguish BRK from TCALL instruction with the same vector address.

**[Direct page flag G]**

This flag assigns RAM page for direct addressing mode. In

the direct addressing mode, addressing area is from zero page 00H to 0FFH when this flag is "0". If it is set to "1", addressing area is 1 Page. It is set by SETG instruction and cleared by CLRG.

**[Overflow flag V]**

This flag is set to "1" when an overflow occurs as the result of an arithmetic operation involving signs. An overflow occurs when the result of an addition or subtraction exceeds +127(7FH) or -128(80H). The CLR V instruction clears the overflow flag. There is no set instruction. When the BIT instruction is executed, bit 6 of memory is copied to this flag.

**[Negative flag N]**

This flag is set to match the sign bit (bit 7) status of the result of a data or arithmetic operation. When the BIT instruction is executed, bit 7 of memory is copied to this flag.

### 8.2 Program Memory

A 16-bit program counter is capable of addressing up to 64K bytes, but this device has 4/8/16/24/32K bytes program memory space only physically implemented. Accessing a location above FFFF<sub>H</sub> will cause a wrap-around to 0000<sub>H</sub>.

Figure 8-5, shows a map of Program Memory. After reset, the CPU begins execution from reset vector which is stored in address FFFE<sub>H</sub> and FFFF<sub>H</sub> as shown in Figure 8-6.

As shown in Figure 8-5, each area is assigned a fixed location in Program Memory. Program Memory area contains the user program.

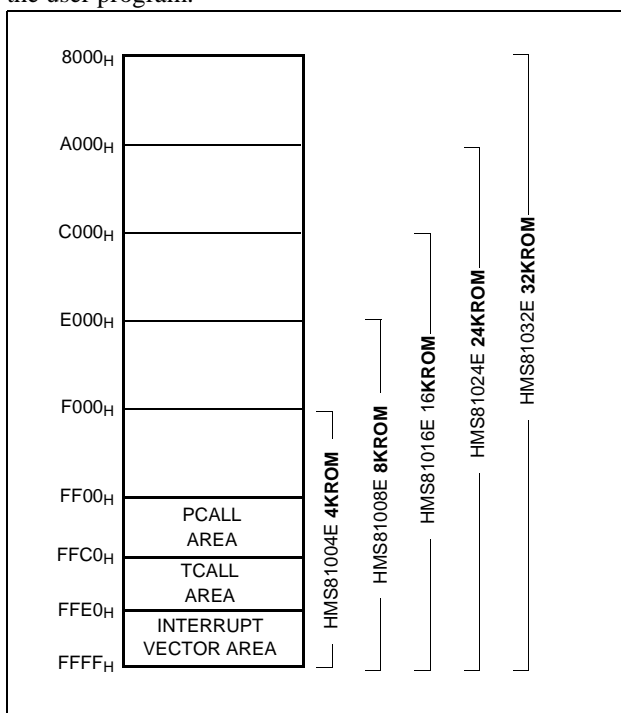

Figure 8-5 Program Memory Map

Page Call (PCALL) area contains subroutine program to reduce program byte length by using 2 bytes PCALL instead of 3 bytes CALL instruction. If it is frequently called, it is more useful to save program byte length.

Table Call (TCALL) causes the CPU to jump to each TCALL address, where it commences the execution of the service routine. The Table Call service area spaces 2-byte for every TCALL: 0FFC0<sub>H</sub> for TCALL15, 0FFC2<sub>H</sub> for TCALL14, etc., as shown in Figure 8-7.

Example: Usage of TCALL

```

LDA    #5
      TCALL 0FH      ; 1BYTE INSTRUCTION
      :             ; INSTEAD OF 2 BYTES
      :             ; NORMAL CALL
;
; TABLE CALL ROUTINE
;
FUNC_A: LDA    LRG0
      RET
;
FUNC_B: LDA    LRG1  (2)
      RET
;
; TABLE CALL ADD. AREA
;
      ORG    0FFC0H  (1)
      DW    FUNC_A
      DW    FUNC_B
    
```

The interrupt causes the CPU to jump to specific location, where it commences the execution of the service routine. The External interrupt 0, for example, is assigned to location 0FFFA<sub>H</sub>. The interrupt service locations spaces 2-byte interval: 0FFF8<sub>H</sub> and 0FFF9<sub>H</sub> for External Interrupt 1, 0FFFA<sub>H</sub> and 0FFFB<sub>H</sub> for External Interrupt 0, etc.

Any area from 0FF00<sub>H</sub> to 0FFFF<sub>H</sub>, if it is not going to be used, its service location is available as general purpose Program Memory.

Address	Vector Area Memory
0FFDE <sub>H</sub>	S/W Interrupt Vector Area
E0	-
E2	-
E4	-
E6	Basic Interval Timer Interrupt Vector Area
E8	Watch Dog Timer Interrupt Vector Area
EA	-
EC	-
EE	Timer2 Interrupt Vector Area
F0	Timer1 Interrupt Vector Area
F2	Timer0 Interrupt Vector Area
F4	-
F6	External Interrupt 2 Vector Area
F8	External Interrupt 1 Vector Area
FA	Key Scan Interrupt Vector Area
FC	-
FE	RESET Vector Area

NOTE:  
 "-" means reserved area.

Figure 8-6 Interrupt Vector Area

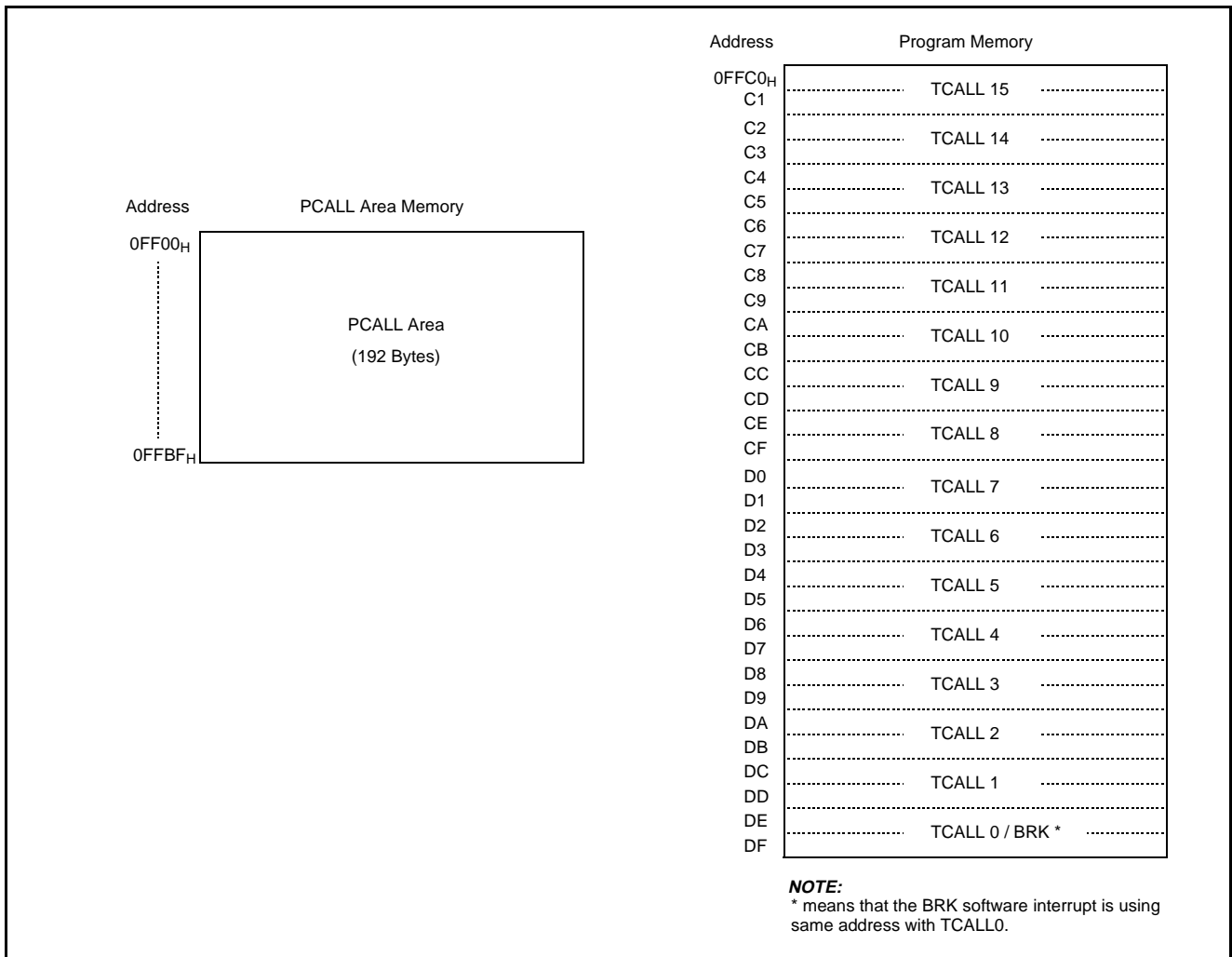
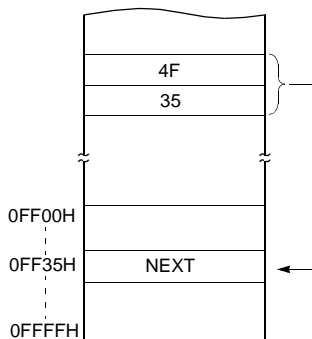

Figure 8-7 PCALL and TCALL Memory Area

**PCALL → rel**

4F35 PCALL 35H



**TCALL → n**

4A TCALL 4

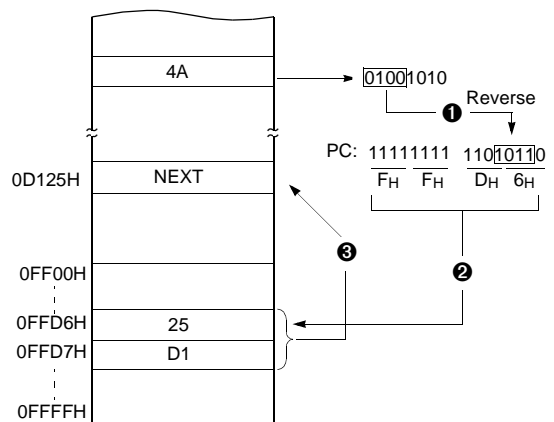

Example: The usage software example of Vector address and the initialize part.

```

        ORG      0FFE0H

        DW      NOT_USED
        DW      NOT_USED
        DW      NOT_USED
        DW      BIT_INT           ; BIT
        DW      WDT_INT           ; Watch Dog Timer
        DW      NOT_USED
        DW      NOT_USED
        DW      TMR2_INT          ; Timer-2
        DW      TMR1_INT          ; Timer-1
        DW      TMR0_INT          ; Timer-0
        DW      NOT_USED         ;
        DW      INT2              ; Int.2
        DW      INT1              ; Int.1
        DW      KEY_INT           ; Key Scan
        DW      NOT_USED         ;
        DW      RESET             ; Reset

        ORG      08000H           ;HMS81032E Program start address

;*****
;
;          MAIN      PROGRAM      *
;*****
;
RESET:    NOP
          CLRG
          DI           ;Disable All Interrupts
          LDX         #0
RAM_CLR:  LDA         #0           ;RAM Clear(!0000H->!00BFH)
          STA         {X}+
          CMPX        #0C0H
          BNE         RAM_CLR     ;

          LDX         #0FFH       ;Stack Pointer Initialize
          TXSP

          LDM         R0, #0       ;Normal Port 0
          LDM         R0DD,#1000_0010B ;Normal Port Direction
          LDM         P0PC,#1000_0010B ;Pull Up Selection Set
          LDM         PMR1,#0000_0010B ;R1 port / int
          :
          :
          LDM         CKCTLR,#0011_1101B ;WDT ON, 16mS Time delay after stop mode release
          :
          :
    
```

### 8.3 Data Memory

Figure 8-8 shows the internal Data Memory space available. Data Memory is divided into 3 groups, a user RAM, control registers, Stack.

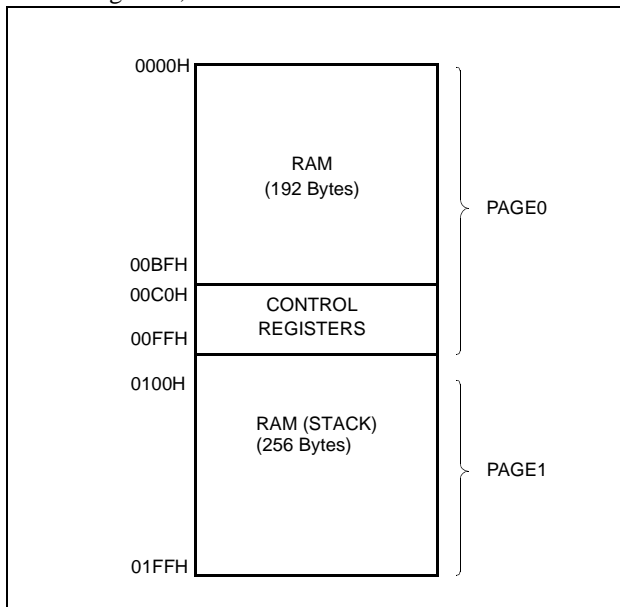

Figure 8-8 Data Memory Map

#### User Memory

The HMS81004E/08E/16E/24E/32E has  $448 \times 8$  bits for the user memory (RAM).

#### Control Registers

The control registers are used by the CPU and Peripheral function blocks for controlling the desired operation of the device. Therefore these registers contain control and status bits for the interrupt system, the timer/ counters, analog to digital converters and I/O ports. The control registers are in address range of 0C0<sub>H</sub> to 0FF<sub>H</sub>.

Note that unoccupied addresses may not be implemented on the chip. Read accesses to these addresses will in general return random data, and write accesses will have an indeterminate effect.

More detailed informations of each register are explained in each peripheral section.

---

**Note:** Write only registers can not be accessed by bit manipulation instruction. Do not use read-modify-write instruction. Use byte manipulation instruction.

---

Example; To write at CKCTRL

```
LDM    CLCTRL, #09H ;Divide ratio +16
```

#### Stack Area

The stack provides the area where the return address is saved before a jump is performed during the processing routine at the execution of a subroutine call instruction or the acceptance of an interrupt.

When returning from the processing routine, executing the subroutine return instruction [RET] restores the contents of the program counter from the stack; executing the interrupt return instruction [RETI] restores the contents of the program counter and flags.

The save/restore locations in the stack are determined by the stack pointer (SP). The SP is automatically decreased after the saving, and increased before the restoring. This means the value of the SP indicates the stack location number for the next save. Refer to Figure 8-3 on page 17.

**8.4 List for Control Registers**

Address	Function Register	Symbol	Read Write	RESET Value
00C0h	PORT R0 DATA REG.	R0	R/W	undefined
00C1h	PORT R0 DATA DIRECTION REG.	R0DD	W	0000000b
00C2h	PORT R1 DATA REG.	R1	R/W	undefined
00C3h	PORT R1 DATA DIRECTION REG.	R1DD	W	0000000b
00C4h	PORT R2 DATA REG.	R2	R/W	undefined
00C5h	PORT R2 DATA DIRECTION REG.	R2DD	W	0000000b
00C6h	reserved			
00C7h	CLOCK CONTROL REG.	CKCTLR	W	--110111b
	BASIC INTERVAL REG.	BITR	R	undefined
00C8h	WATCH DOG TIMER REG.	WDTR	W	-0001111b
00C9h	PORT R1 MODE REG.	PMR1	W	0000000b
00CAh	INT. MODE REG.	IMOD	R/W	--00000b
00CBh	EXT. INT. EDGE SELECTION	IEDS	W	--0000--b
00CCh	INT. ENABLE REG. LOW	IENL	R/W	-00----b
00CDh	INT. REQUEST FLAG REG. LOW	IRQL	R/W	-00----b
00CEh	INT. ENABLE REG. HIGH	IENH	R/W	000-000-b
00CFh	INT. REQUEST FLAG REG. HIGH	IRQH	R/W	000-000-b
00D0h	TIMER0 (16bit) MODE REG.	TM0	R/W	0000000b
00D1h	TIMER1 (8bit) MODE REG.	TM1	R/W	0000000b
00D2h	TIMER2 (8bit) MODE REG.	TM2	R/W	0000000b
00D3h	TIMER0 HIGH-MSB DATA REG.	T0HMD	W	undefined
00D4h	TIMER0 HIGH-LSB DATA REG.	T0HLD	W	undefined
	TIMER0 LOW-MSB DATA REG.	T0LMD	W	undefined
00D5h	TIMER0 HIGH-MSB COUNT REG.		R	undefined
	TIMER0 LOW-LSB DATA REG.	T0LLD	W	undefined
00D6h	TIMER0 LOW-LSB COUNT REG.		R	undefined
	TIMER1 HIGH DATA REG.	T1HD	W	undefined
00D7h	TIMER1 LOW DATA REG.	T1LD	W	undefined
	TIMER1 LOW COUNT REG.		R	undefined
00D8h	TIMER2 DATA REG.	T2DR	W	undefined
	TIMER2 COUNT REG.		R	undefined
00D9h	TIMER0 / TIMER1 MODE REG.	TM01	R/W	0000000b
00DAh	Reserved			
00DBh	Reserved			
00DCh	STANDBY MODE RELEASE REG0	SMPR0	W	0000000b
00DDh	STANDBY MODE RELEASE REG0	SMPR1	W	0000000b
00DEh	PORT R1 OPEN DRAIN ASSIGN REG.	R1ODC	W	0000000b

00DFh	PORT R2 OPEN DRAIN ASSIGN REG.	R2ODC	W	0000000b
00E0h	Reserved			
00E1h	Reserved			
00E2h	Reserved			
00E3h	Reserved			
00E4h	PORT R0 OPEN DRAIN ASSIGN REG.	R0ODC	W	0000000b
00E5h	Reserved			
00E6h	Reserved			
00E7h	Reserved			
00E8h	Reserved			
00E9h	Reserved			
00EAh	Reserved			
00EBh	Reserved			
00ECh	Reserved			
00EDh	Reserved			
00EEh	Reserved			
00EFh	Reserved			
00F0h	SLEEP MODE REG.	SLPM	W	----- 0b
00F1h	Reserved			
00F2	Reserved			
00F3h	Reserved			
00F4h	Reserved			
00F5h	Reserved			
00F6h	STANDBY RELEASE LEVEL CONT. REG. 0	SRLC0	W	0000000b
00F7h	STANDBY RELEASE LEVEL CONT. REG. 1	SRLC1	W	0000000b
00F8h	PORT R0 PULL-UP REG. CONT. REG.	R0PC	W	0000000b
00F9h	PORT R1 PULL-UP REG. CONT. REG.	R1PC	W	0000000b
00FAh	PORT R2 PULL-UP REG. CONT. REG.	R2PC	W	0000000b
00FBh	Reserved			
00FCh	Reserved			
00FDh	Reserved			
00FEh	Reserved			
00FFh	Reserved			

W

Registers are controlled by byte manipulation instruction such as LDM etc., do not use bit manipulation instruction such as SET1, CLR1 etc. If bit manipulation instruction is used on these registers, content of other seven bits are may varied to unwanted value.

R/W

Registers are controlled by both bit and byte manipulation instruction.

- : this bit location is reserved.

### 8.5 Addressing Mode

The HMS81004E/08E/16E/24E/32E uses six addressing modes;

- Register addressing
- Immediate addressing
- Direct page addressing
- Absolute addressing
- Indexed addressing
- Register-indirect addressing

#### (1) Register Addressing

Register addressing accesses the A, X, Y, C and PSW.

#### (2) Immediate Addressing → #imm

In this mode, second byte (operand) is accessed as a data immediately.

Example:

```
0435   ADC   #35H
```

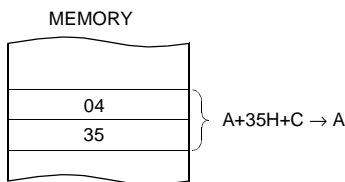

When G-flag is 1, then RAM address is defined by 16-bit address which is composed of 8-bit RAM paging register (RPR) and 8-bit immediate data.

Example: G=1, RPR=0CH

```
E45535  LDM  35H, #55H
```

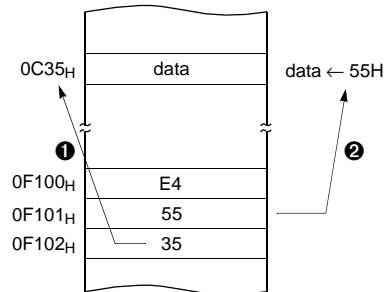

#### (3) Direct Page Addressing → dp

In this mode, a address is specified within direct page.

Example; G=0

```
C535   LDA  35H           ;A ←RAM[35H]
```

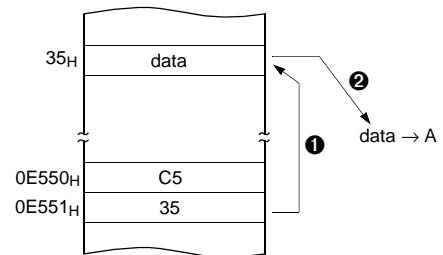

#### (4) Absolute Addressing → !abs

Absolute addressing sets corresponding memory data to Data, i.e. second byte (Operand I) of command becomes lower level address and third byte (Operand II) becomes upper level address.

With 3 bytes command, it is possible to access to whole memory area.

ADC, AND, CMP, CMPX, CMPY, EOR, LDA, LDX, LDY, OR, SBC, STA, STX, STY

Example;

```
0735F0  ADC    !0F035H    ;A←ROM[0F035H]
```

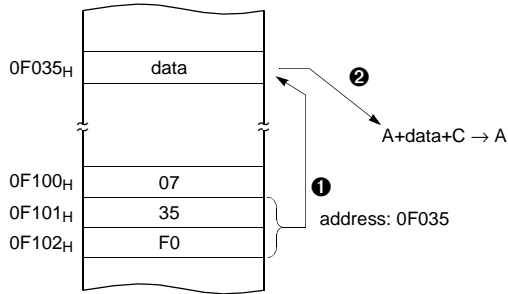

The operation within data memory (RAM)  
ASL, BIT, DEC, INC, LSR, ROL, ROR

Example; Addressing accesses the address 0135H regardless of G-flag and RPR.

```
983501  INC    !0135H    ;A ←ROM[135H]
```

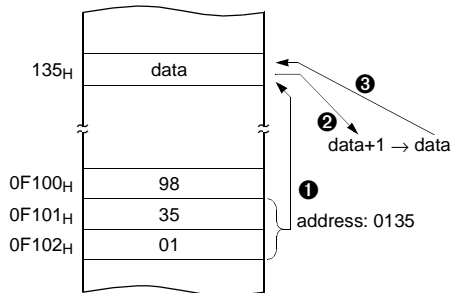

**(5) Indexed Addressing**

**X indexed direct page (no offset) → {X}**

In this mode, a address is specified by the X register.

ADC, AND, CMP, EOR, LDA, OR, SBC, STA, XMA

Example; X=15H, G=1, RPR=01H

```
D4      LDA    {X}      ;ACC←RAM[X].
```

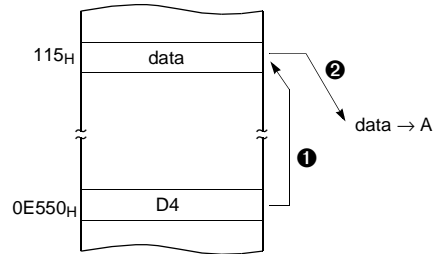

**X indexed direct page, auto increment → {X}+**

In this mode, a address is specified within direct page by the X register and the content of X is increased by 1.

LDA, STA

Example; G=0, X=35H

```
DB      LDA    {X}+
```

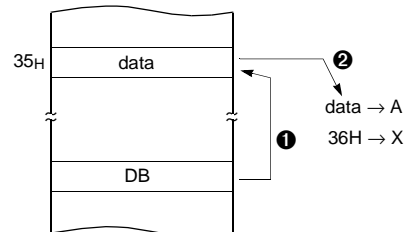

**X indexed direct page (8 bit offset) → dp+X**

This address value is the second byte (Operand) of command plus the data of X-register. And it assigns the memory in Direct page.

ADC, AND, CMP, EOR, LDA, LDY, OR, SBC, STA, STY, XMA, ASL, DEC, INC, LSR, ROL, ROR

Example; G=0, X=0F5H

C645 LDA 45H+X

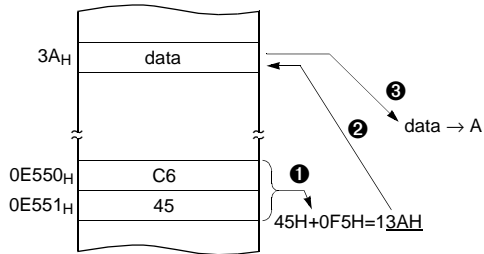

**Y indexed direct page (8 bit offset) → dp+Y**

This address value is the second byte (Operand) of command plus the data of Y-register, which assigns Memory in Direct page.

This is same with above (2). Use Y register instead of X.

**Y indexed absolute → !abs+Y**

Sets the value of 16-bit absolute address plus Y-register data as Memory. This addressing mode can specify memory in whole area.

Example; Y=55H

D500FA LDA !0FA00H+Y

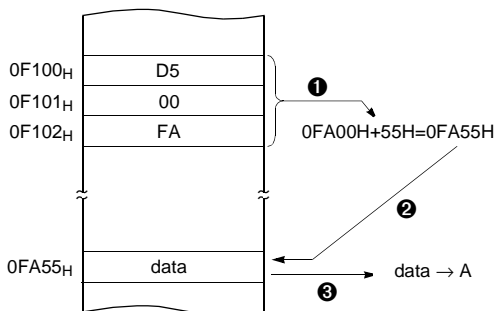

**(6) Indirect Addressing**

**Direct page indirect → [dp]**

Assigns data address to use for accomplishing command which sets memory data (or pair memory) by Operand. Also index can be used with Index register X, Y.

**JMP, CALL**

Example; G=0

3F35 JMP [35H]

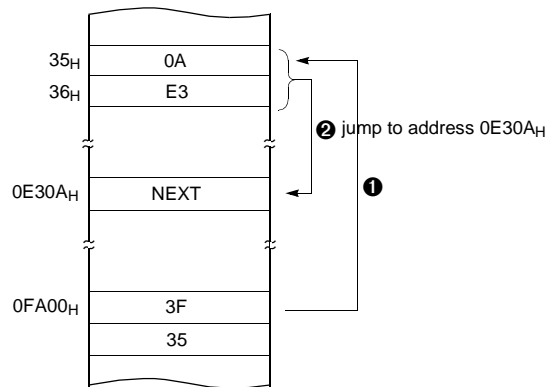

**X indexed indirect → [dp+X]**

Processes memory data as Data, assigned by 16-bit pair memory which is determined by pair data [dp+X+1][dp+X] Operand plus X-register data in Direct page.

ADC, AND, CMP, EOR, LDA, OR, SBC, STA

Example; G=0, X=10H

1625 ADC [25H+X]

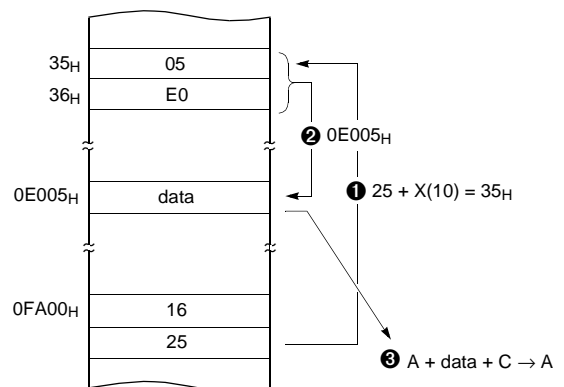

**Y indexed indirect → [dp]+Y**

Processes memory data as Data, assigned by the data [dp+1][dp] of 16-bit pair memory paired by Operand in Direct page plus Y-register data.

ADC, AND, CMP, EOR, LDA, OR, SBC, STA

Example; G=0, Y=10<sub>H</sub>

1725    ADC    [25H]+Y

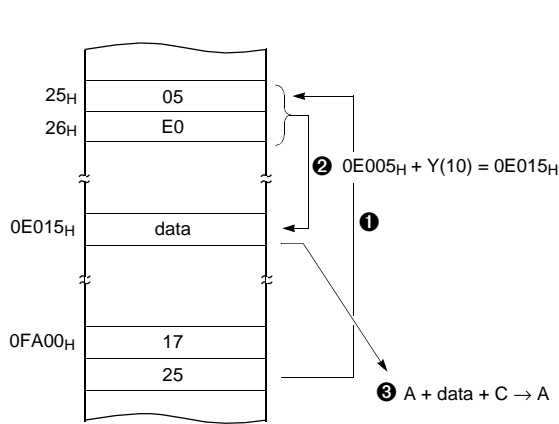

**Absolute indirect → [!abs]**

The program jumps to address specified by 16-bit absolute address.

JMP

Example; G=0

1F25E0    JMP    [!0C025H]

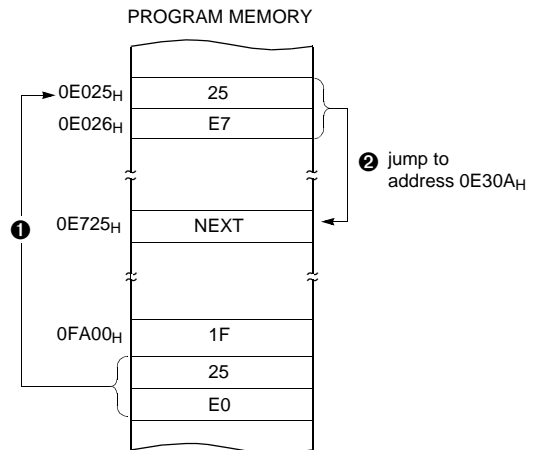

## 9. I/O PORTS

The HMS81004E/08E/16E/24E/32E has 24 I/O ports which are PORT0(8 I/O), PORT1 (8 I/O), PORT2 (8 I/O). Pull-up resistor of each port can be selectable by program. Each port contains data direction register which controls I/O and data register which stores port data.

### 9.1 R0 Ports

R0 is an 8-bit CMOS bidirectional I/O port (address 0C0H). Each I/O pin can independently used as an input or an output through the R0DD register (address 0C1H).

R0 has internal pull-ups that is independently connected or disconnected by R0PC. The control registers for R0 are shown below.

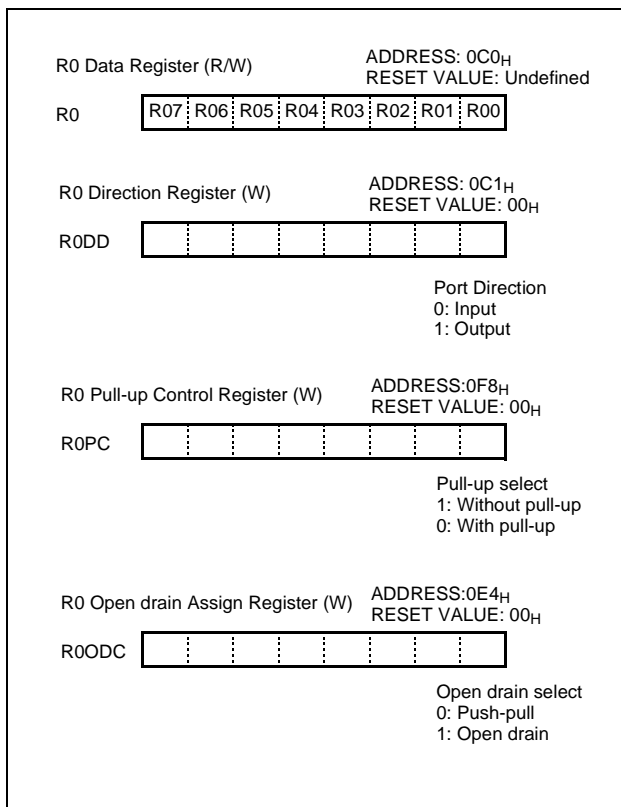

#### (1) R0 I/O Data Direction Register (R0DD)

R0 I/O Data Direction Register (R0DD) is 8-bit register, and can assign input state or output state to each bit. If R0DD is “1”, port R0 is in the output state, and if “0”, it is in the input state. R0DD is write-only register. Since R0DD is initialized as “00h” in reset state, the whole port R0 becomes input state.

#### (2) R0 Data Register (R0)

R0 data register (R0) is 8-bit register to store data of port R0. When set as the output state by R0DD, and data is written in R0, data is output into R0 pin. When set as the input state, input state of pin is read. The initial value of R0 is unknown in reset state.

#### (3) R0 Open drain Assign Register (R0ODC)

R0 Open Drain Assign Register (R0ODC) is 8bit register, and can assign R0 port as open drain output port each bit, if corresponding port is selected as output. If R0ODC is selected as “1”, port R0 is open drain output, and if selected as, “0” it is push-pull output. R0ODC is write-only register and initialized as “00h” in reset state.

#### (4) R0 Pull-up Control Register (R0PC)

R0 Pull-up Control Register (R0PC) is 8-bit register and can control pull-up on or off each bit, if corresponding port is selected as input. If R0PC is selected as “1”, pull-up is disabled and if selected as “0”, it is enabled. R0PC is write-only register and initialized as “00h” in reset state. The pull-up is automatically disabled, if corresponding port is selected as output.

### 9.2 R1 Ports

R1 is an 8-bit CMOS bidirectional I/O port (address 0C2H). Each I/O pin can independently used as an input or an output through the R1DD register (address 0C3H).

R1 has internal pull-ups that is independently connected or disconnected by register R1PC. The control registers for R1 are shown below.

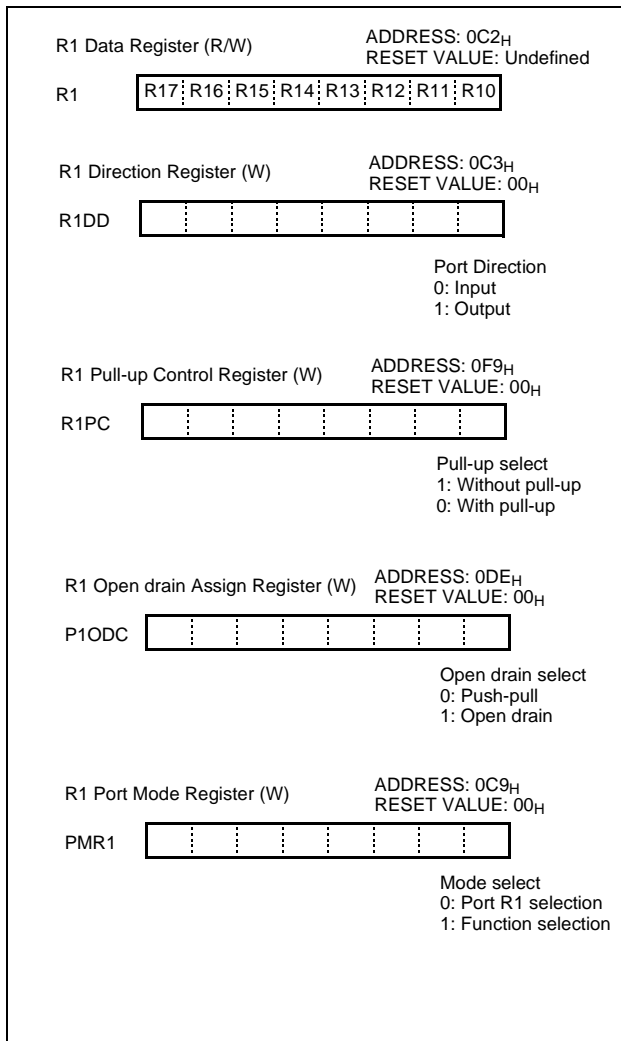

**(1) R1 I/O Data Direction Register (R1DD)**

R1 I/O Data Direction Register (R1DD) is 8-bit register, and can assign input state or output state to each bit. If R1DD is “1”, port R1 is in the output state, and if “0”, it is in the input state. R1DD is write-only register. Since R1DD is initialized as “00h” in reset state, the whole port R1 becomes input state.

**(2) R1 Data Register (R1)**

R1 data register (R1) is 8-bit register to store data of port R1. When set as the output state by R1DD, and data is written in R1, data is output into R1 pin. When set as the input state, input state of pin is read. The initial value of R1 is unknown in reset state.

**(3) R1 Open drain Assign Register (R1ODC)**

R1 Open Drain Assign Register (R1ODC) is 8bit register,

and can assign R1 port as open drain output port each bit, if corresponding port is selected as output. If R1ODC is selected as “1”, port R1 is open drain output, and if selected as “0”, it is push-pull output. R1ODC is write-only register and initialized as “00h” in reset state.

**(4) R1 Port Mode Register (PMR1)**

R1 Port Mode Register (PMR1) is 8-bit register, and can assign the selection mode for each bit. When set as “0”, corresponding bit of PMR1 acts as port R1 selection mode, and when set as “1”, it becomes function selection mode.

PMR1 is write-only register and initialized as “00h” in reset state. Therefore, becomes Port selection mode. Port R1 can be I/O port by manipulating each R1DD bit, if corresponding PMR1 bit is selected as “0”.

Bit Name	PMR1	Selection Mode	Remarks
T0S	0	R17 (I/O)	-
	1	T0 (O)	Timer0
T1S	0	R16 (I/O)	-
	1	T1 (O)	Timer1
T2S	0	R15 (I/O)	-
	1	T2 (O)	Timer2
ECS	0	R14 (I/O)	-
	1	$\overline{EC}$ (I)	Timer0 Event
INT2S	0	R12 (I/O)	
	1	INT2 (I)	Timer0 Input Capture
INT1S	0	R11 (I/O)	
	1	INT1 (I)	

**Table 9-1 Selection mode of PMR1**

**(5) R1 Pull-up Control Register (R1PC)**

R1 Pull-up Control Register (R1PC) is 8-bit register and can control pull-up on or off each bit, if corresponding port is selected as input. If R1PC is selected as “1”, pull-up is disabled and if selected as “0”, it is enabled. R1PC is write-only register and initialized as “00h” in reset state. The

pull-up is automatically disabled, if corresponding port is selected as output.

### 9.3 R2 Port

R2 is an 8-bit CMOS bidirectional I/O port (address 0C4H). Each I/O pin can independently used as an input or an output through the R2DD register (address 0C5H).

R2 has internal pull-ups that is independently connected or disconnected by R2PC (address 0FAH). The control registers for R2 are shown as below.

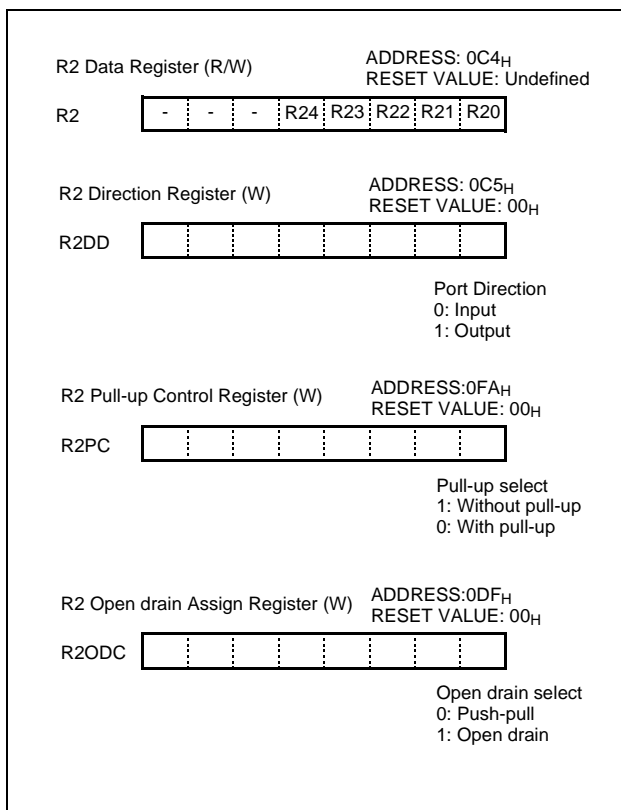

#### (1) R2 I/O Data Direction Register (R2DD)

R2 I/O Data Direction Register (R2DD) is 8-bit register, and can assign input state or output state to each bit. If R2DD is “1”, port R2 is in the output state, and if “0”, it is in the input state. R2DD is write-only register. Since R2DD is initialized as “00h” in reset state, the whole port R2 becomes input state.

#### (2) R2 Data Register (R2)

R2 data register (R2) is 8-bit register to store data of port R2. When set as the output state by R2DD, and data is written in R2, data is outputted into R2 pin. When set as the input state, input state of pin is read. The initial value of R2 is unknown in reset state.

#### (3) R2 Open drain Assign Register (R2ODC)

R2 Open Drain Assign Register (R2ODC) is 8bit register, and can assign R2 port as open drain output port each bit, if corresponding port is selected as output. If R2ODC is selected as “1”, port R2 is open drain output, and if selected as “0”, it is push-pull output. R2ODC is write-only register and initialized as “00h” in reset state.

#### (4) R2 Pull-up Control Register (R2PC)

R2 Pull-up Control Register (R2PC) is 8-bit register and can control pull-up on or off each bit, if corresponding port is selected as input. If R2PC is selected as “1”, pull-up ia disabled and if selected as ”0”, it is enabled. R2PC is write-only register and initialized as “00h” in reset state. The pull-up is automatically disabled, if corresponding port is selected as output.

### 10. CLOCK GENERATOR

Clock generating circuit consists of Clock Pulse Generator (C.P.G), Prescaler, Basic Interval Timer (B.I.T) and Watch Dog Timer. The clock applied to the Xin pin divided by two is used as the internal system clock.

Prescaler consist of 12-bit binary counter. The clock supplied from oscillation circuit is input to prescaler(fex)

The divided output from each bit of prescaler is provided to peripheral hardware

Clock to peripheral hardware can be stopped by bit4 (EN-PCK) of CKCTRL Register. ENPCK is set to “1” in reset

state.

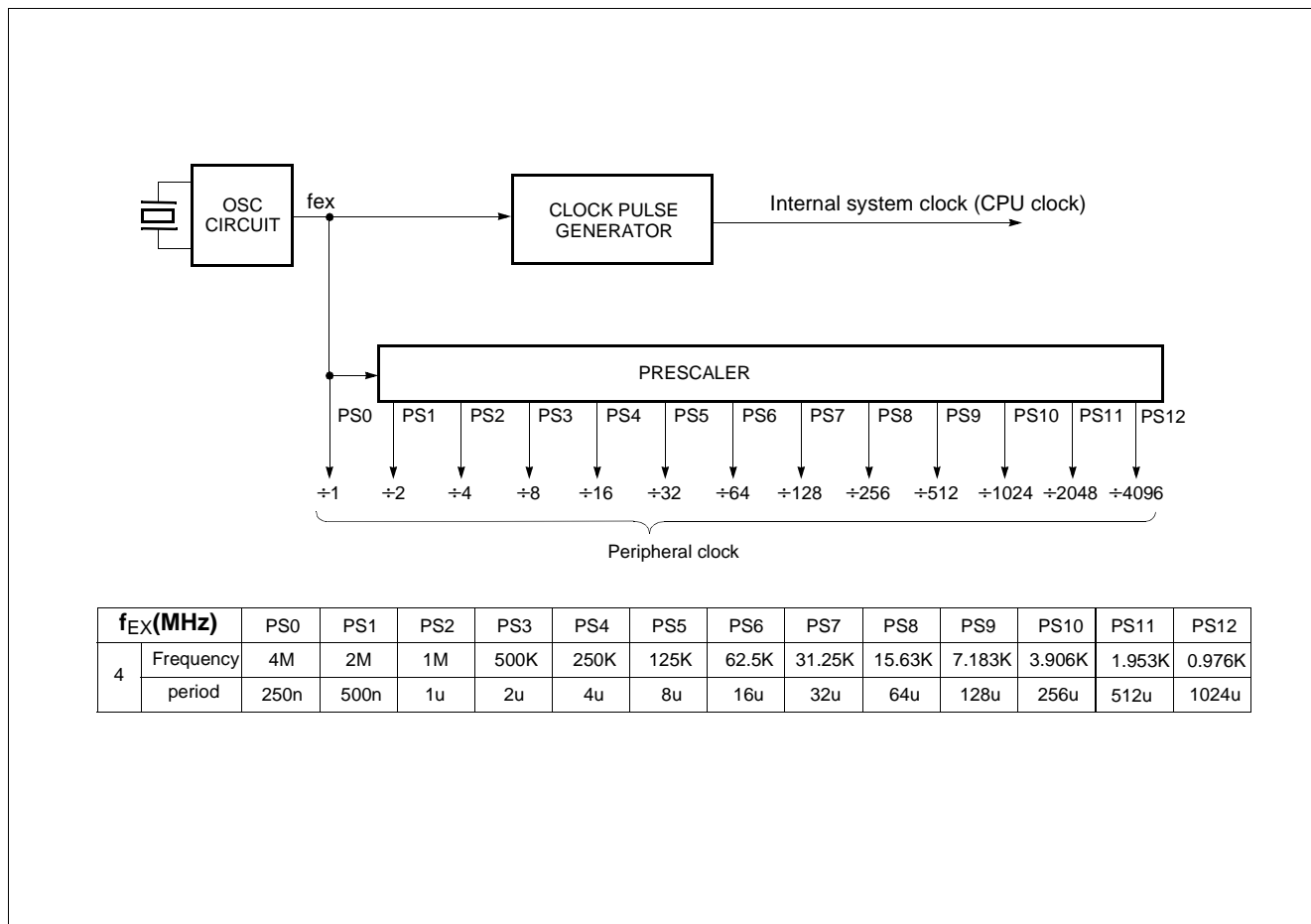
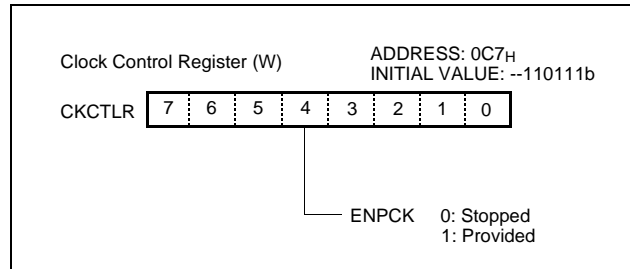

Figure 10-1 Block diagram of Clock Generator

### 10.1 Oscillation Circuit

Oscillation circuit is designed to be used either with a ceramic resonator or crystal oscillator. Figure 10-2 shows circuit diagrams using a crystal (or ceramic) oscillator. As shown in the diagram, oscillation circuits can be constructed by connecting an oscillator between Xout and Xin. Clock from oscillation circuit makes CPU clock via clock pulse generator, and then enters prescaler to make peripheral hardware clock. Alternately, the oscillator may be driven from an external source as Figure 10-3 . In the STOP mode, oscillation stop, Xout state goes to "HIGH" , Xin state goes to "LOW" , and built-in feed back resistor is disabled.

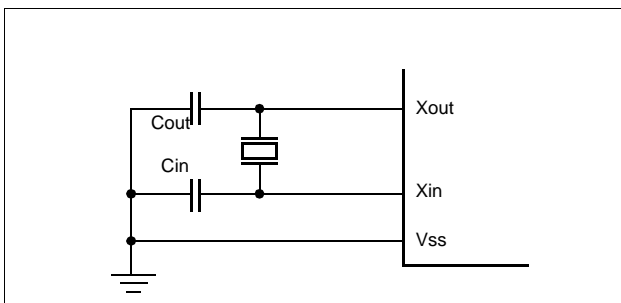

Figure 10-2 External Crystal(Ceramic) oscillator circuit

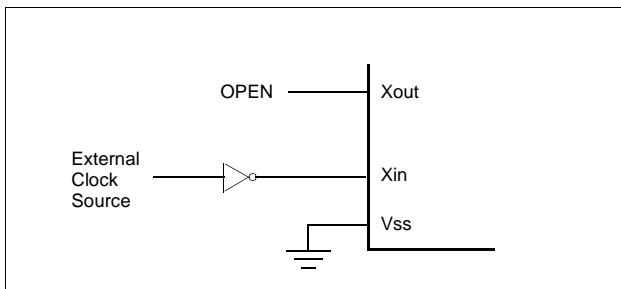

Figure 10-3 External clock input circuit

Oscillation circuit is designed to be used either with a ceramic resonator or crystal oscillator. Since each crystal and ceramic resonator have their own characteristics, the user should consult the crystal manufacturer for appropriate values of external components. In addition, see Figure 10-4 for the layout of the crystal.

**Note:** Minimize the wiring length. Do not allow the wiring to intersect with other signal conductors. Do not allow the wiring to come near changing high current. Set the potential of the grounding position of the oscillator capacitor to that of Vss. Do not ground it to any ground pattern where high current is present. Do not fetch signals from the oscillator.

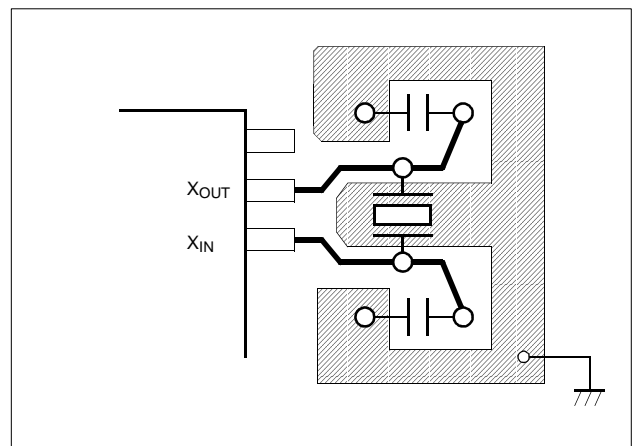

Figure 10-4 Recommend Layout of Oscillator PCB circuit

Frequency	Resonator Maker	Part Name	Load Capacitor	Operating Voltage
2.00MHz	CQ	ZTT2.00	Cin=Cout=open	2.0~3.6
	CQ	ZTA2.00	Cin=Cout=30pF	2.0~3.6
	MURATA	CSTLS2M00G56-B0	Cin=Cout=open	2.0~3.6
	MURATA	CSTCC2.00MG0H6	Cin=Cout=open	2.0~3.6
	MURATA	CSTCC2M00G56-R0	Cin=Cout=open	2.0~3.6
4.00MHz	CQ	ZTT4.00	Cin=Cout=open	2.0~3.6
	CQ	ZTA4.00	Cin=Cout=30pF	2.0~3.6
	MURATA	CSTS0400MG06	Cin=Cout=open	2.0~3.6
	MURATA	CSTLS4M00G56-B0	Cin=Cout=open	2.0~3.6
	MURATA	CSTCR4M00G55-R0	Cin=Cout=open	2.0~3.6
	TDK	FCR4.0MC5	Cin=Cout=open	2.0~3.6
	TDK	FCR4.0MSC5	Cin=Cout=open	2.0~3.6
	CORETECH	CRT4.00MS	Cin=Cout=open	2.0~3.6
CORETECH	CRM4.00MS	Cin=Cout=30pF	2.0~3.6	

Table 10-1 recommendatory resonator

### 11. BASIC INTERVAL TIMER

The HMS81004E/08E/16E/24E/32E has one 8-bit Basic Interval Timer that is free-run and can not stop. Block diagram is shown in Figure 11-1.

The Basic Interval Timer generates the time base for Standby release time, watchdog timer counting, and etc. It also provides a Basic interval timer interrupt (IFBIT). As the count overflow from FF<sub>H</sub> to 00<sub>H</sub>, this overflow causes the interrupt to be generated.

- 8bit binary up-counter
- Use the bit output of prescaler as input to secure the oscillation stabilization time after power-on
- Secures the oscillation stabilization time in standby mode (stop mode) release
- Contents of B.I.T can be read
- Provides the clock for watch dog timer

The Basic Interval Timer is controlled by the clock control register (CKCTRL) shown in Figure 11-2. If bit3(BTCL) of CKCTRL is set to "1", B.I.T is cleared, and then, after one machine cycle, BTCL becomes "0", and B.I.T starts counting. BTCL is set to "0" in reset state.

The input clock of B.I.T can be selected from the prescaler within a range of 2us to 256us by clock input selection bits (BTS2~BTS0). (at fex = 4MHz). In reset state, or power on reset, BTS2="1", BTS1= "1", BTS0= "1" to secure the longest oscillation stabilization time. B.I.T can generate the wide range of basic interval time interrupt request (IFBIT) by selecting prescaler output.

By reading of the Basic Interval Timer Register (BITR), we can read counter value of B.I.T. Because B.I.T can be cleared or read, the spending time up to maximum 65.5ms can be available. B.I.T is read-only register. If B.I.T register is written, then CKCTRL register with same address is written.

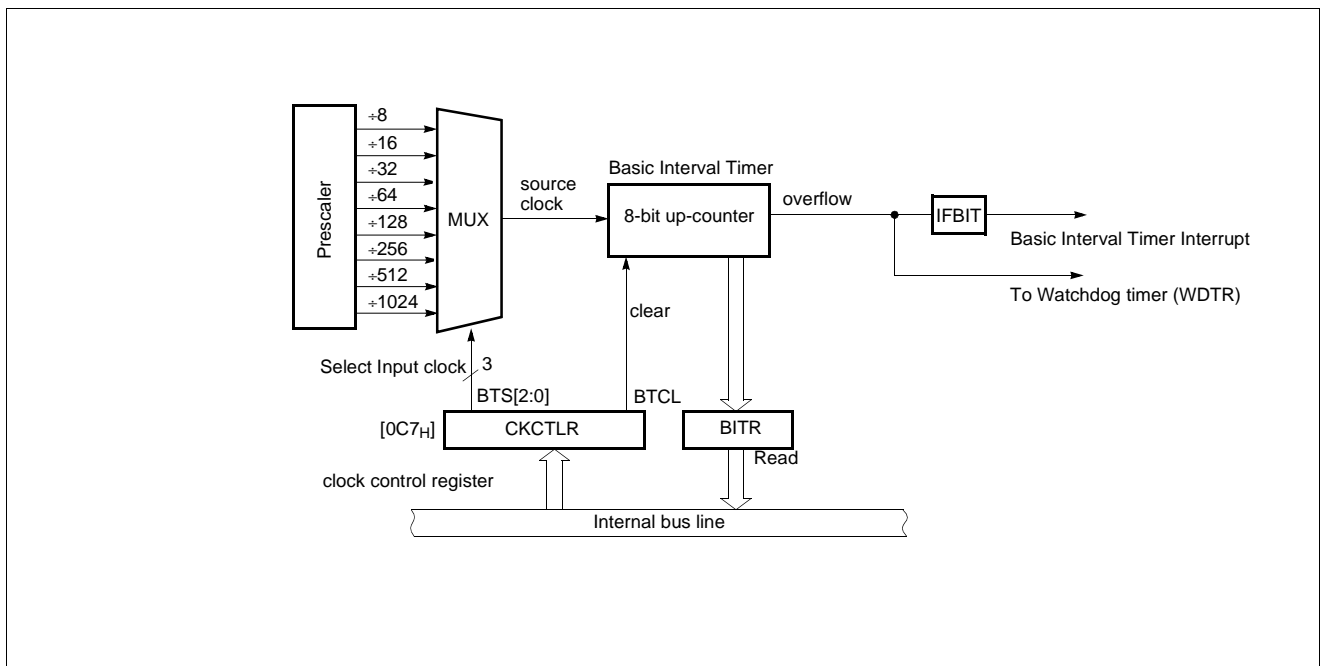

Figure 11-1 Block diagram of Basic Interval Timer

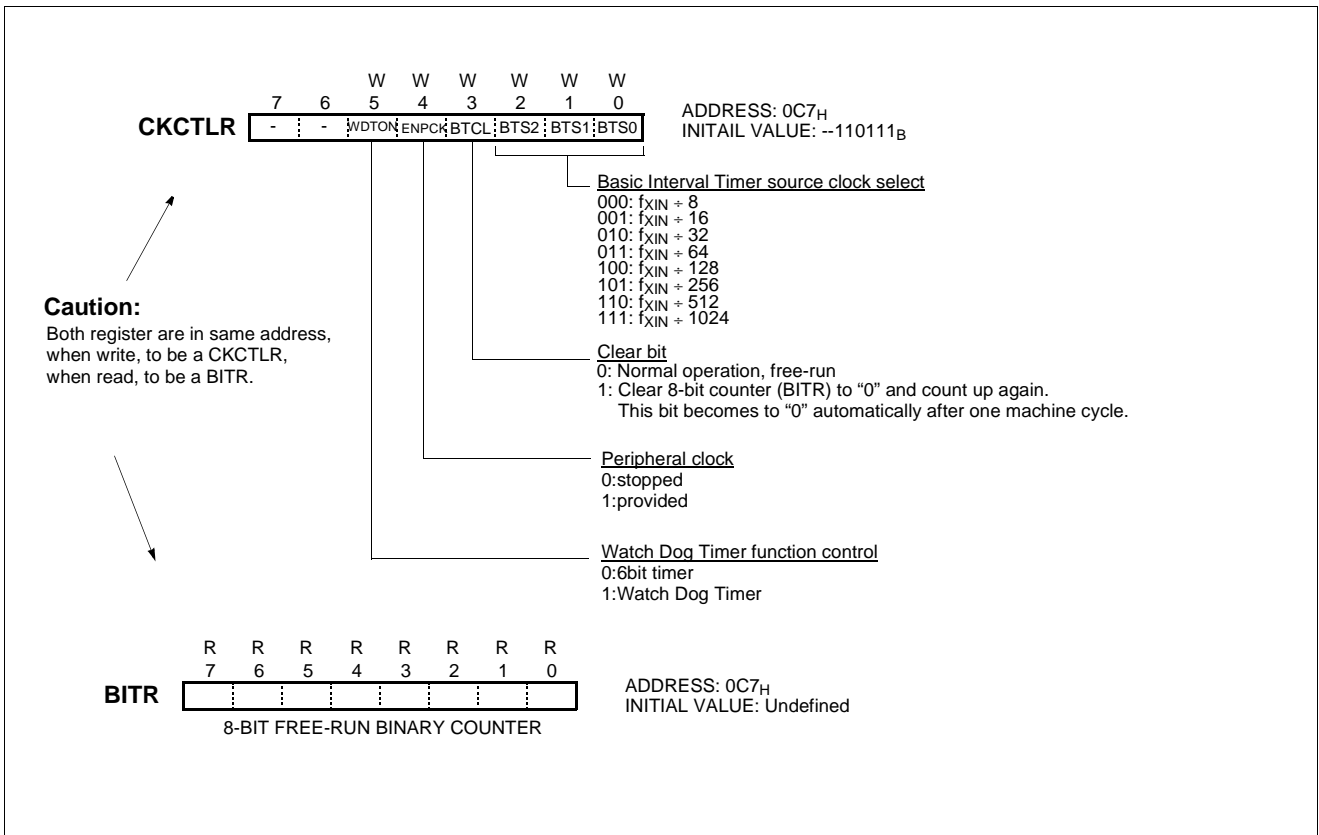

Figure 11-2 CKCTLR AND BITR

BTS[2:0]	CPU Source clock	B.I.T. Input clock@4Mhz(us)	Standby release time(ms)
000	÷ 8	2	0.512
001	÷16	4	1.024
010	÷32	8	2.048
011	÷64	16	4.096
100	÷128	32	8.192
101	÷256	64	16.384
110	÷512	128	32.768
111	÷1024	256	65.536

## 12. WATCH DOG TIMER

Watch Dog Timer (WDT) consists of 6-bit binary counter, 6-bit comparator, and Watch Dog Timer Register (WDTR). Watch Dog Timer can be used 6-bit general Timer or specific Watch dog timer by setting bit5 (WDTON) of Clock Control Register (CKCTRL). By assigning bit6(WDTCL) of WDTR, 6-bit counter can be cleared.

WDT Interrupt (IFWDT) interval is determined by the interrupt IFBIT interval of Basic Interval Timer and the value of WDT Register.

-Interval of IFWDT = (IFBIT interval) \* (WDTR value)

As IFBIT (Basic Interval Timer Interrupt Request) is used for input clock of WDT, Input clock cycle is possible from 512 us to 65,536 us by BTS. (at fex = 4MHz)

\*At Hardware reset time, WDT starts automatically. Therefore the user must select the CKCTRL and WDTR before WDT overflow.

-Reset WDTR value = 0F<sub>h</sub>,=15

-Interval of WDT = 65,536 \* 15 = 983040 us

(about 1second)

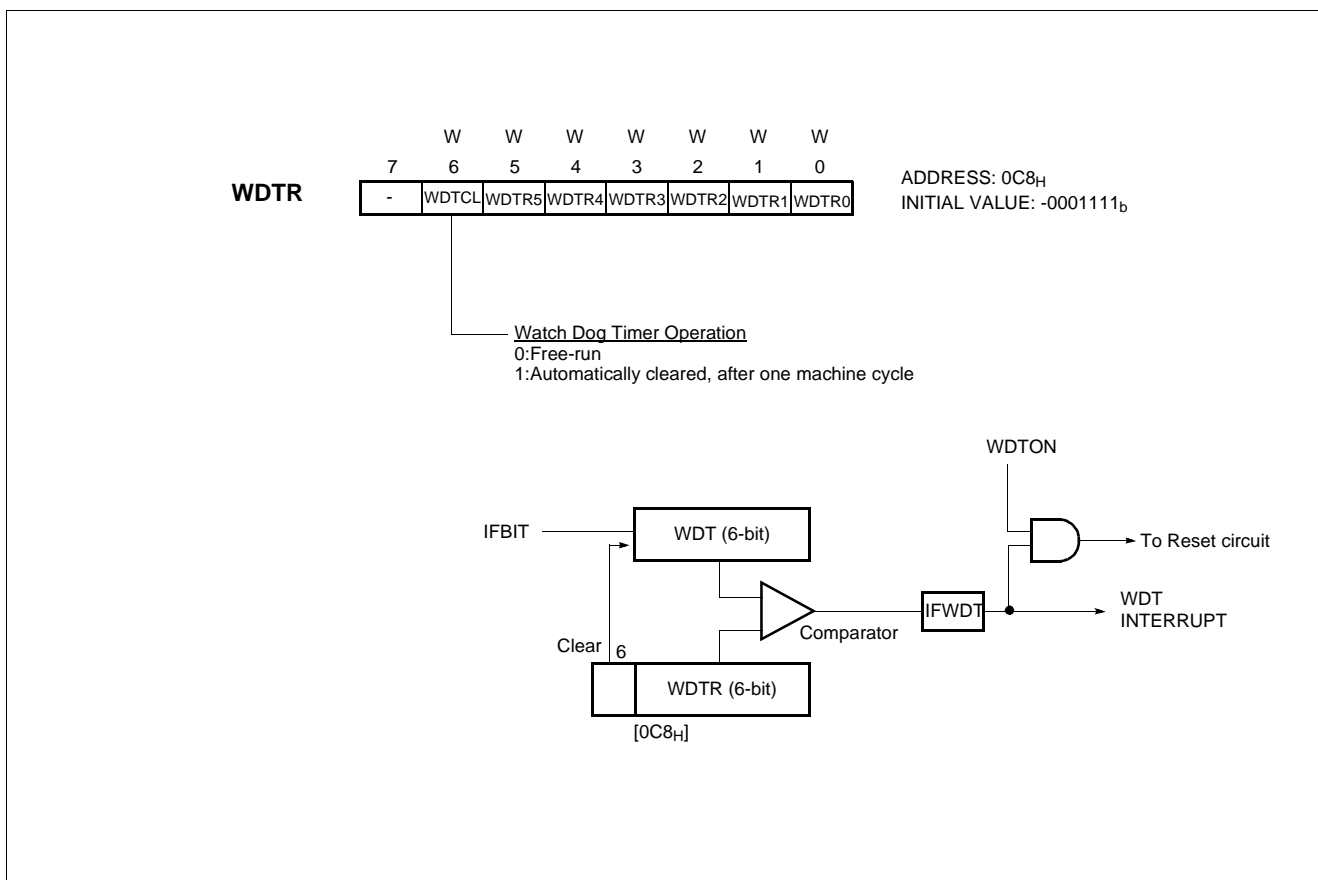

Figure 12-1 Block diagram of Watch Dog Timer

**Note:** When WDTR Register value is 63 (3F<sub>h</sub>)  
(Caution): Do not use "0" for WDTR Register value.

Device come into the reset state by WDT

## 13. Timer0, Timer1, Timer2

### (1) Timer Operation Mode

Timer consists of 16bit binary counter Timer0 (T0), 8bit binary Timer1 (T1), Timer2 (T2), Timer Data Register, Timer Mode Register (TM01, TM0, TM1, TM2) and control circuit. Timer Data Register Consists of Timer0 High-MSB Data Register (T0HMD), Timer0 High-LSB Data Register (T0HLD), Timer0 Low-MSB Data Register (T0LMD), Timer0 Low-LSB Data Register (T0LLD), Timer1 High Data Register (T1HD), Timer1 Low Data

Register (T1LD), Timer2 Data Register (T2DR). Any of the PS0 ~ PS5, PS11 and external event input  $\overline{EC}$  can be selected as clock source for T0. Any of the PS0 ~ PS3, PS7 ~ PS10 can be selected as clock T1. Any of the PS5 ~ PS12 can be selected as clock source for T2.

\* Relevant Port Mode Register (PMR1: 00C9h) value should be assigned for event counter.

Timer0	- 16-bit Interval Timer - 16-bit Event Counter - 16-bit Input Capture - 16-bit rectangular-wave output	- Single/Modulo-N Mode - Timer Output Initial Value Setting - Timer0~Timer1 combination Logic Output - One Interrupt Generating Every 2nd Counter Overflow
Timer1	- 8-bit Interval Timer - 8-bit rectangular-wave output	
Timer2	- 8-bit Interval Timer - 8-bit rectangular-wave output - Modulo-N Mode	

Table 13-1 Timer Operation

16bit Timer (T0)		8bit Timer (T1)		8bit Timer (T2)	
Resolution	MAX. Count	Resolution	MAX. Count	Resolution	MAX. Count
PS0 (0.25us)	16,384us	PS0 (0.25us)	64us	PS5 (8us)	2,048us
PS1 (0.5us)	32,768us	PS1 (0.5us)	128us	PS6 (16us)	4,096us
PS2 (1us)	65,536us	PS2 (1us)	256us	PS7 (32us)	8,192us
PS3 (2us)	131,072us	PS3 (2us)	512us	PS8 (64us)	16,384us
PS4 (4us)	262,144us	PS7 (32us)	8,192us	PS9 (128us)	32,768us
PS5 (8us)	524,288us	PS8 (64us)	16,384us	PS10 (256us)	65,536us
PS11 (512us)	33,554,432us	PS9 (128us)	32,768us	PS11 (512us)	131,072us
$\overline{EC}$	-	PS10 (256us)	65,536us	PS12 (1024us)	262,144us

Table 13-2 Function of Timer & Counter

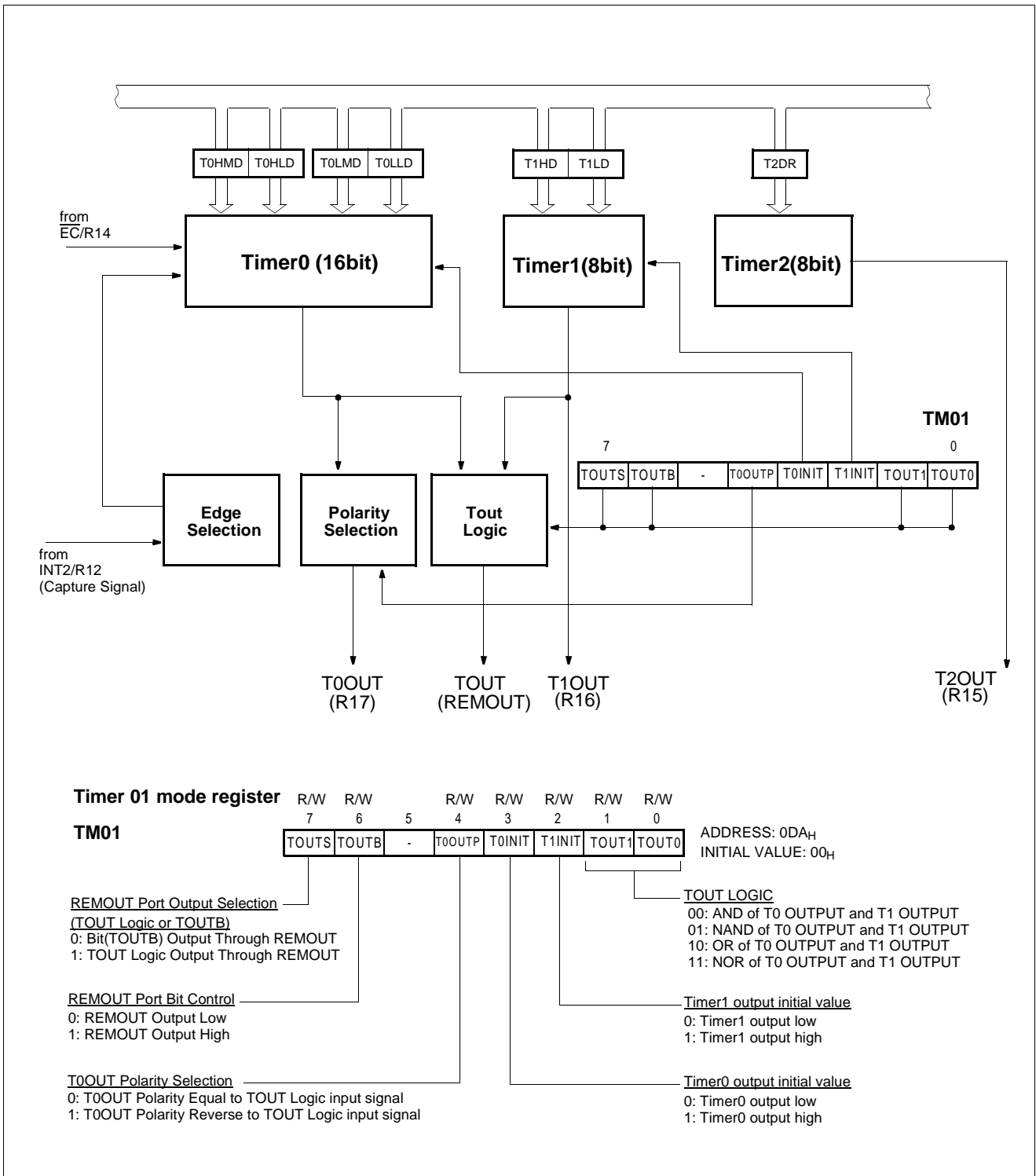

Figure 13-1 Block Diagram of Timer/Counter

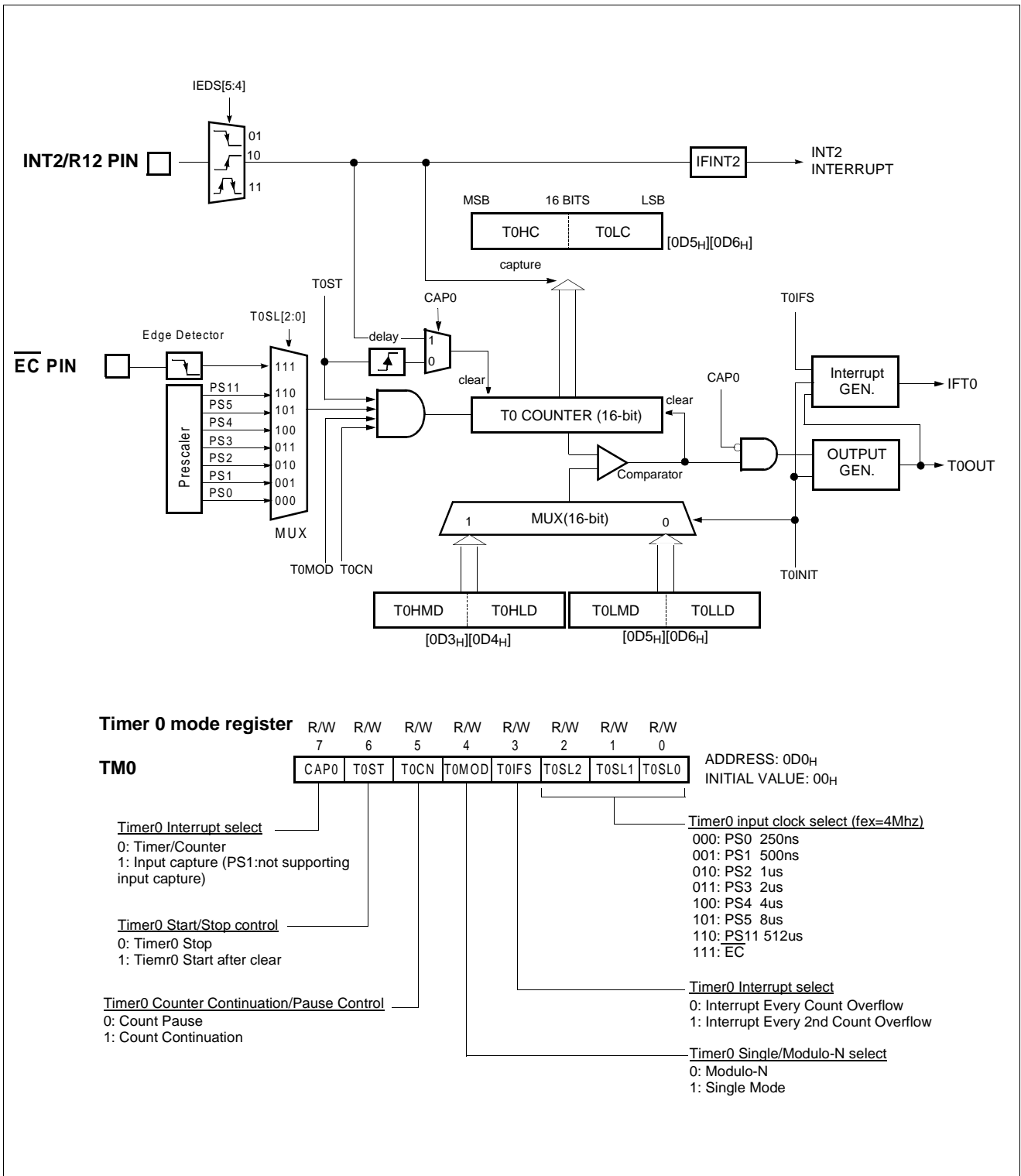

Figure 13-2 Block Diagram of Timer0

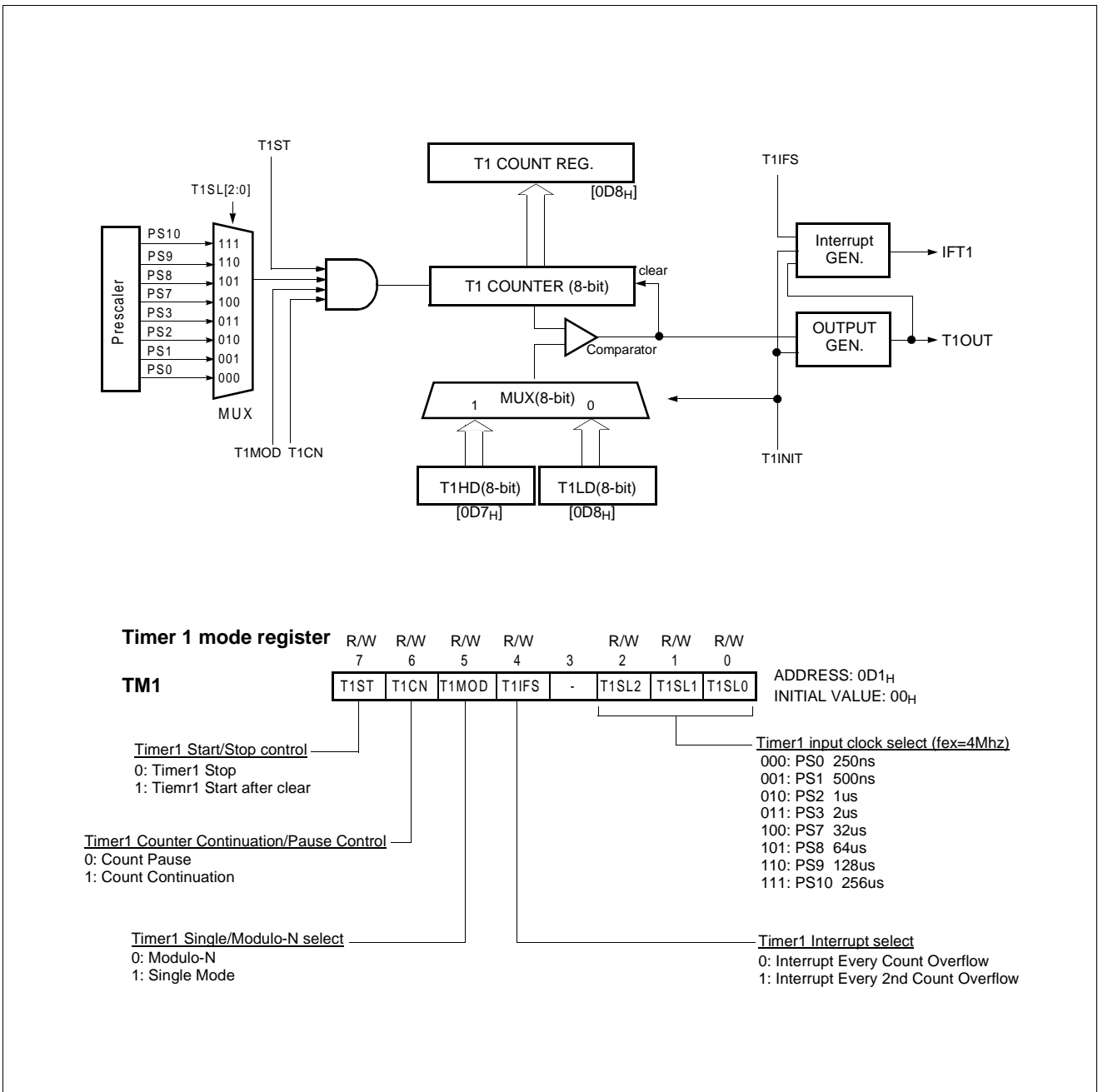

Figure 13-3 Block Diagram of Timer1

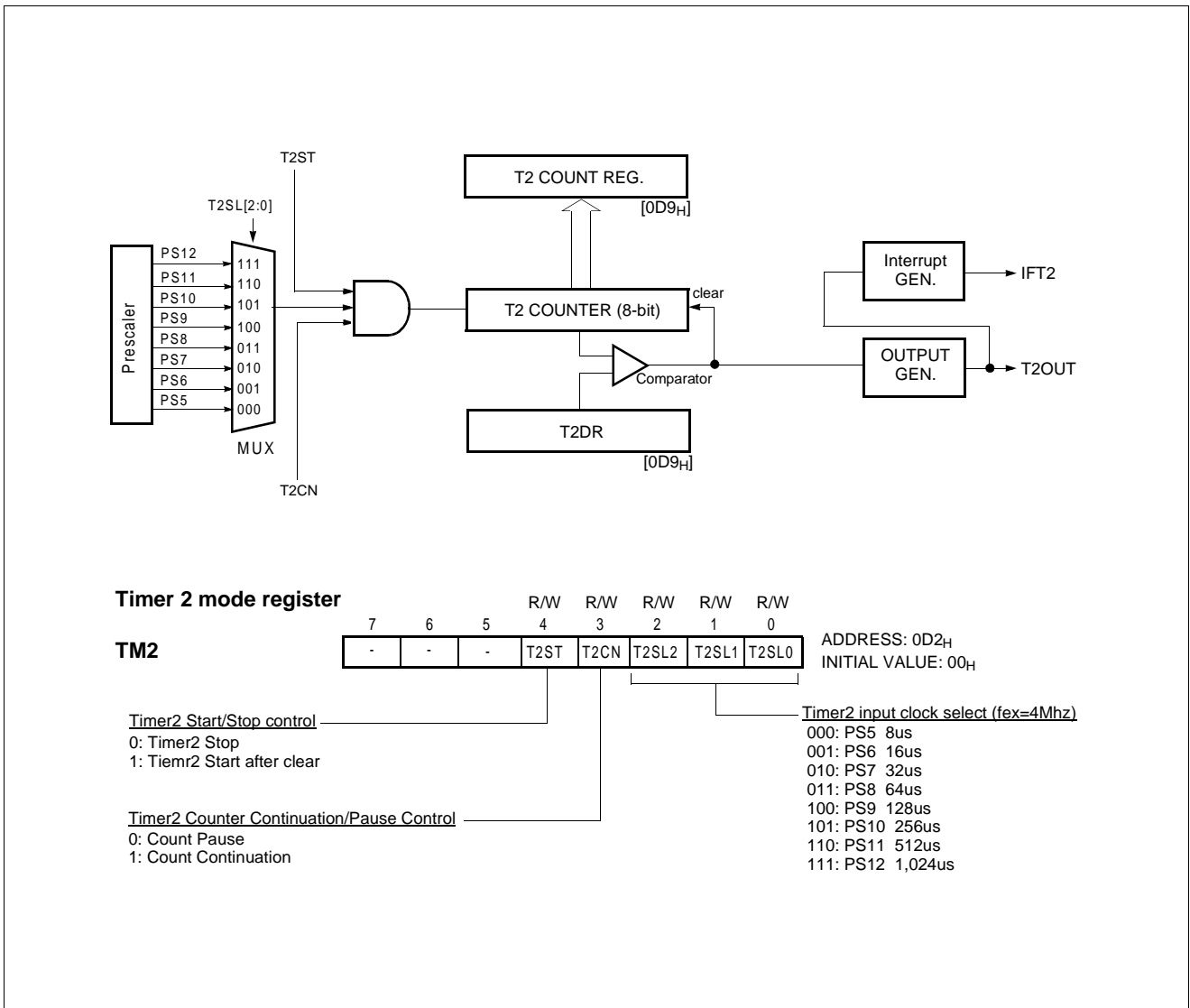

Figure 13-4 Block Diagram of Timer2

## 2) Timer0, Timer1

TIMER0 and TIMER1 have an up-counter. When value of the up-counter reaches the content of Timer Data Register

(TDR), the up-counter is cleared to "00h", and interrupt (IFT0, IFT1) is occurred at the next clock.

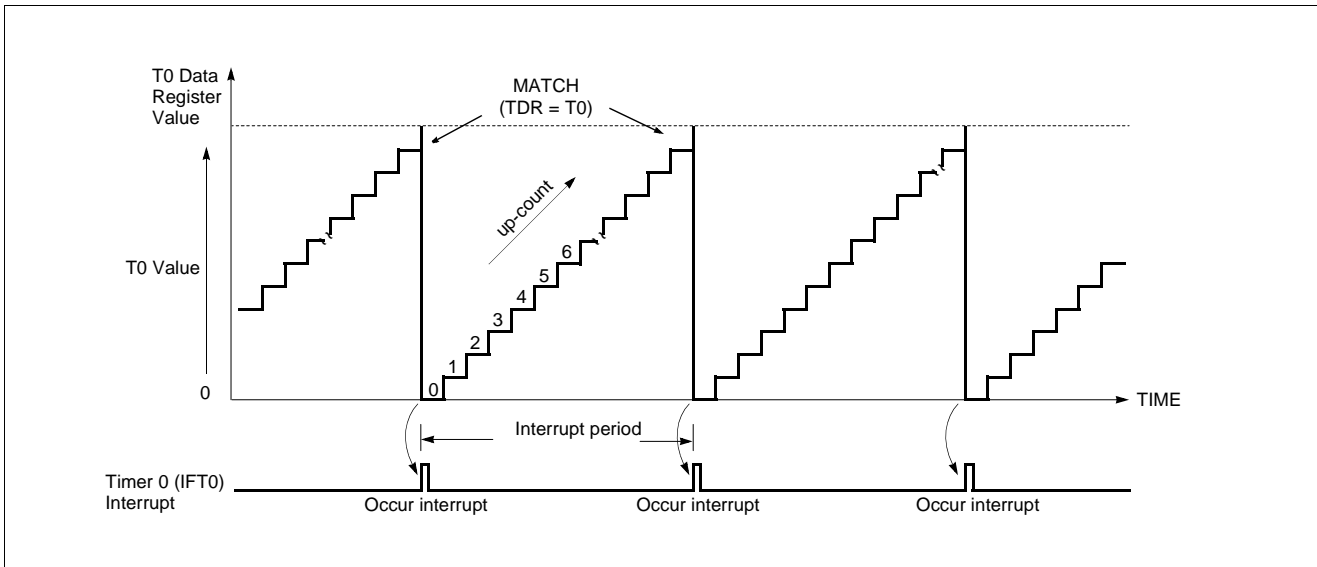

Figure 13-5 Operation of Timer0

For Timer0, the internal clock (PS) and the external clock ( $\overline{EC}$ ) can be selected as counter clock. But Timer1 and Timer2 use only internal clock. As internal timer, Timer0 can be used as an internal timer whose period is determined by the Timer Data Register (TDR). Chosen as an external clock, Timer0 executes as an event counter. The counter execution of Timer0 and Timer1 is controlled by T0CN, T0ST, CAP0, T1CN, T1ST, of the Timer Mode Register TM0 and TM1. T0CN, T1CN are used to stop and start Timer0 and Timer1 without clearing the counter. T0ST, T1ST is used to clear the counter. For clearing and starting the counter, T0ST or T1ST should be temporarily set to "0" and then set to "1". T0CN, T1CN, T0ST and T1ST should be set "1", when Timer counting-up. Controlling of CAP0 enables Timer0 as an input capture. By programming of CAP0 to "1", the period of signal from INT2 can be measured and then, event counter value for INT2 can be read. During counting-up, value of counter can be read from Timer

execution is stopped by the reset signal (RESET="L")

**Note:** In the process of reading 16-bit Timer Data, first read the upper 8-bit data. Then read the lower 8-bit data, and read the upper 8-bit data again. If the earlier read upper 8-bit data are matched with the later read upper 8-bit data, read 16-bit data are correct. If not, caution should be taken in the selection of upper 8-bit data.

(Example)

- 1) Upper 8-bit Read 0A 0A
- 2) Lower 8-bit Read FF 01
- 3) Upper 8-bit Read 0B 0B

=====

0AFF 0B01

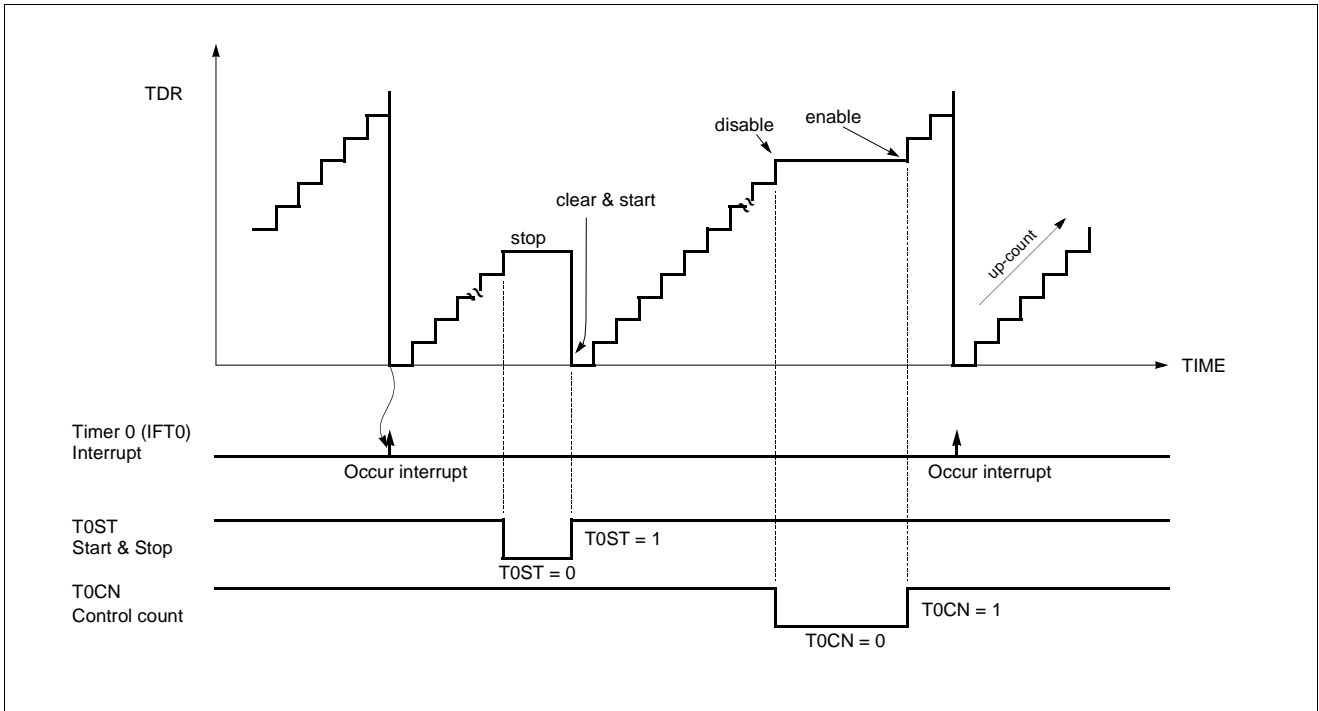

Figure 13-6 Start/Stop Operation of Timer0

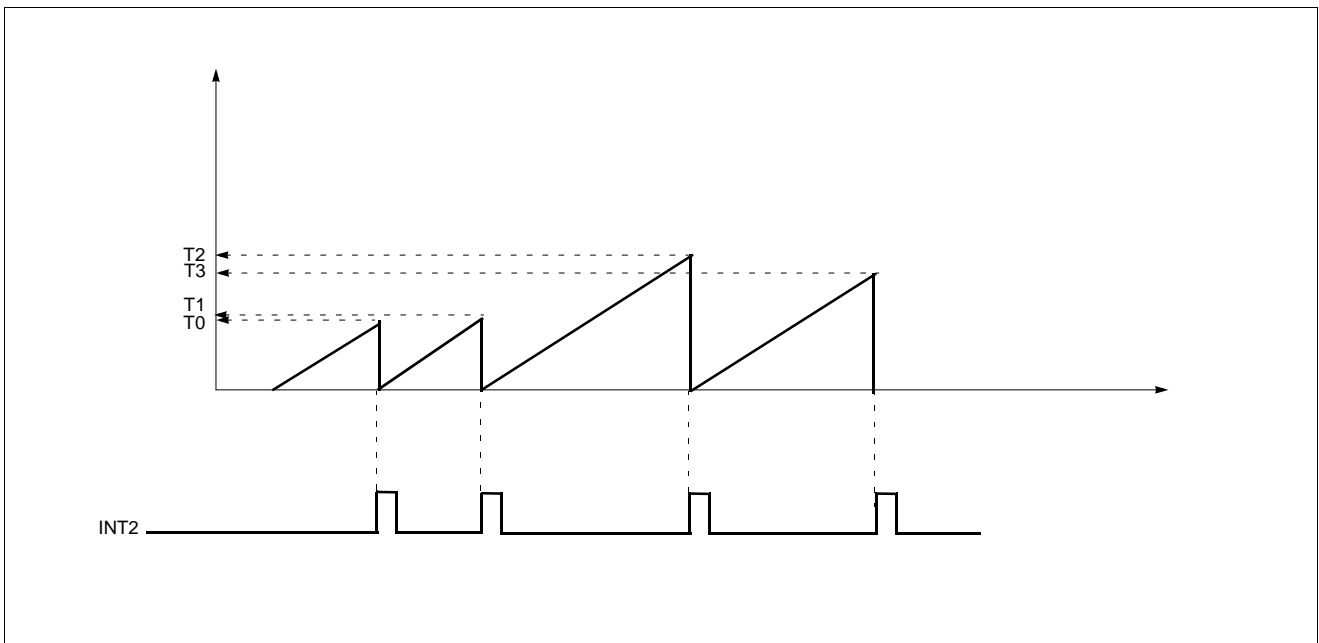

Figure 13-7 Input capture operation of Timer0

### 3) Single/Modulo-N Mode

Timer0 (Timer1) can select initial (T0INIT, T1INIT of TM01) output level of Timer Output port. If initial level is “L”, Low-Data Register value of Timer Data Register is transferred to comparator and T0OUT (T1OUT) is to be “Low”, if initial level is High? High -Data Register is transferred and to be “High”. Single Mode can be set by Mode Select bit (T0MOD, T1MOD) of Timer Mode Register (TM0, TM1) to “1” When used as Single Mode, Timer counts up and compares with value of Data Register. If the result is same, Time Out interrupt occurs and level of Timer Output port toggle, then counter stops as reset state. When used as Modulo-N Mode, T0MOD (T1MOD)

should be set “0”. Counter counts up until the value of Data Register and occurs Time-out interrupt. The level of Timer Output port toggle and repeats process of

counting the value which is selected in Data Register. During Modulo-N Mode, If interrupt select bit (TOIFS, T1IFS) of Mode Register is “0”, Interrupt occurs on every Time-out. If it is “1”, Interrupt occurs every second time-out.

**Note:** Timer Output is toggled whenever time out happen

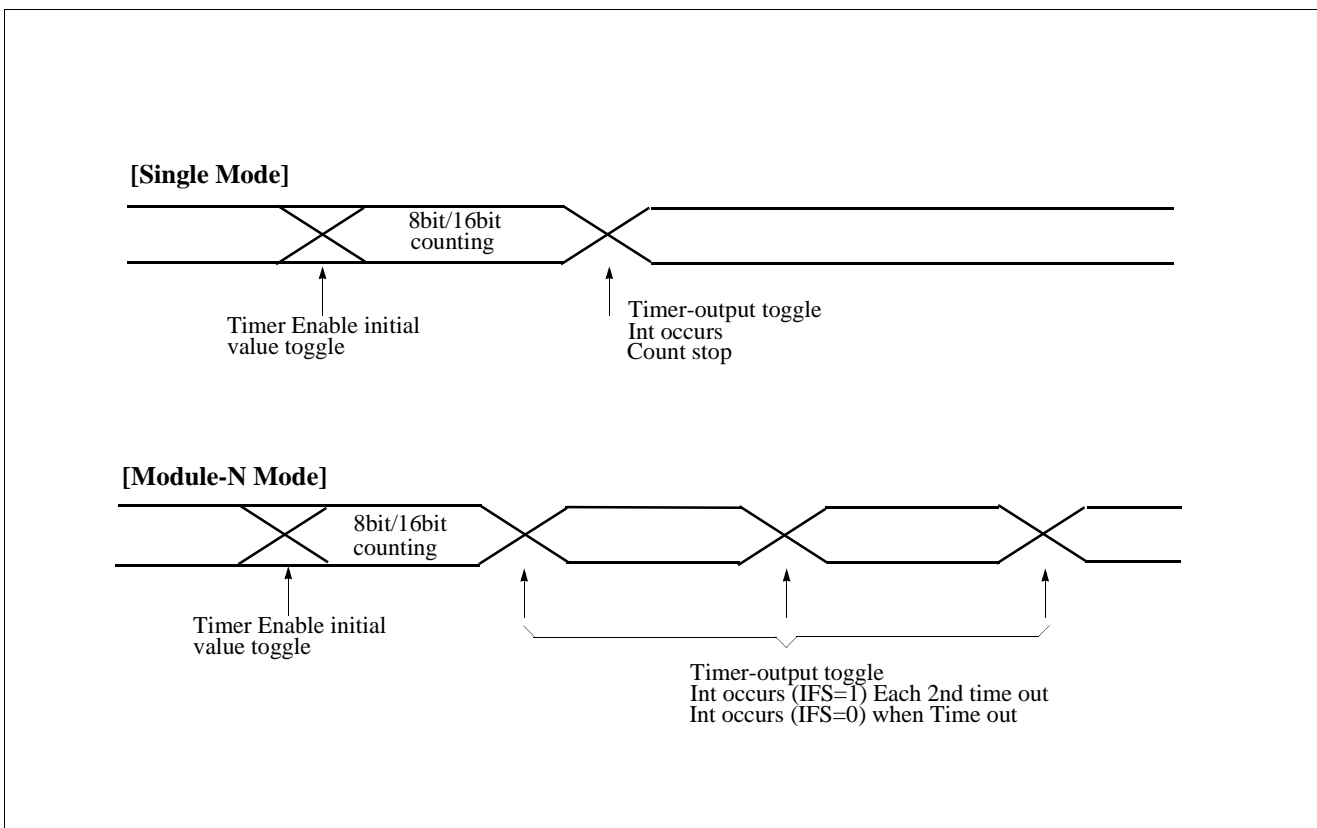

Figure 13-8 Operation Diagram for Single/Modulo-N Mode

### (4) Timer 2

Timer2 operates as a up-counter. The content of T2DR are compared with the contents of up-counter. If a match is found. Timer2 interrupt (IFT2) is generated and the up-counter is cleared to “00h”. Therefore, Timer2 executes as a interval timer. Interrupt period is determined by the count source clock for the Timer2 and content of T2DR.

When T2ST is set to “1”, count value of Timer 2 is cleared and starts counting-up. For clearing and starting the Timer2. T2ST have to set to “1” after set to “0”. In order to write a value directly into the T2DR, T2ST should be set to “0”. Count value of Timer2 can be read at any time.

## 14. INTERRUPTS

The HMS81004E/08E/16E/24E/32E interrupt circuits consist of Interrupt Mode Register (MOD), Interrupt enable register (IENH, IENL), Interrupt request flags of IRQH, IRQL, Priority circuit and Master enable flag ("I" flag of PSW). 8 interrupt sources are provided. The configuration of interrupt circuit is shown in Figure 14-1.

The HMS81004E/08E/16E/24E/32E contains 8 interrupt sources; 3 externals and 5 internals. Nested interrupt services with priority control is also possible. Software interrupt is non-maskable interrupt, the others are all maskable interrupts.

- 8 interrupt source (2Ext, 3Timer, BIT, WDT and Key Scan)
- 8 interrupt vector
- Nested interrupt control is possible
- Programmable interrupt mode (Hardware and software interrupt accept mode)
- Read and write of interrupt request flag are possible.
- In interrupt accept, request flag is automatically cleared.

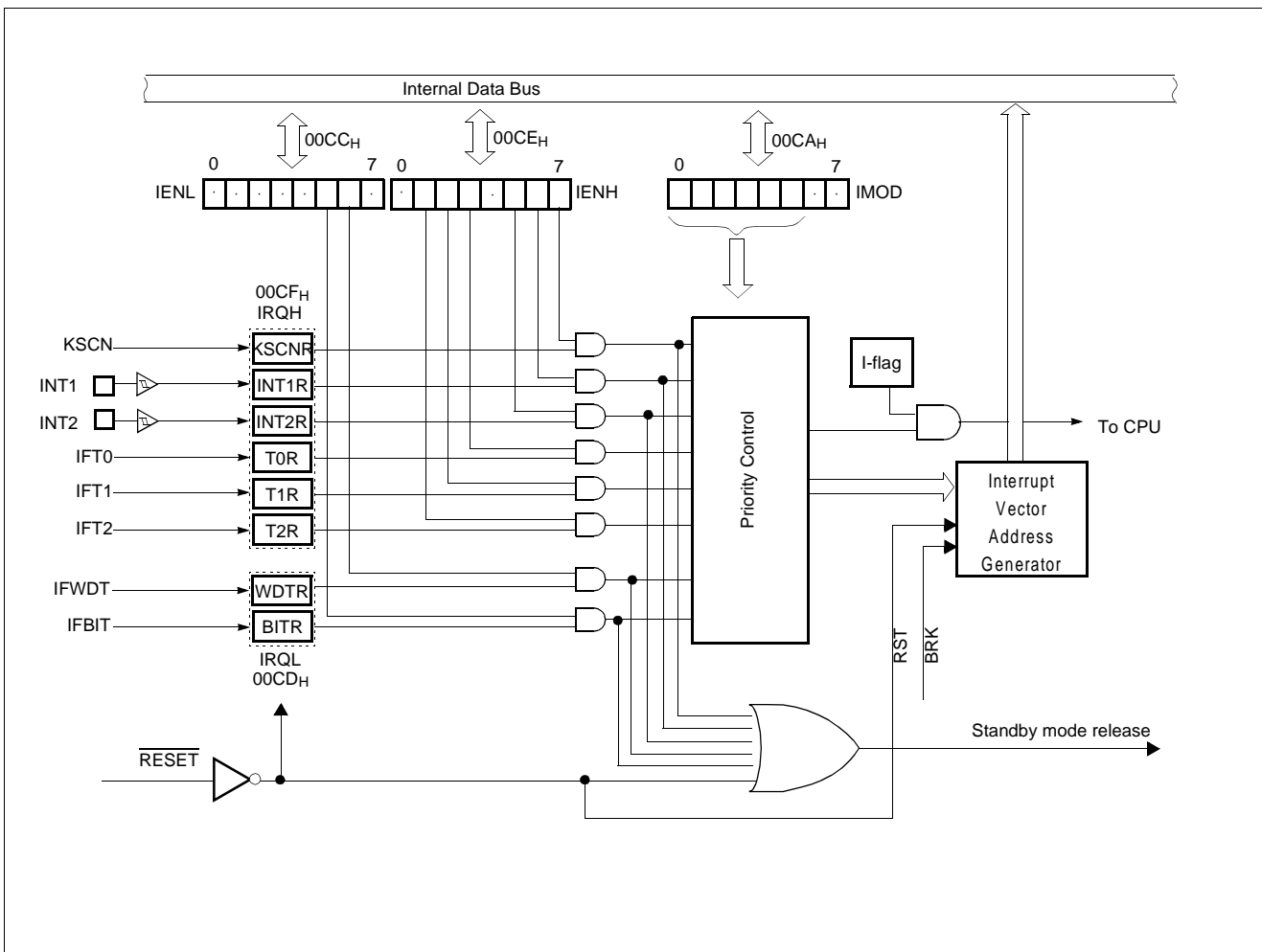

Figure 14-1 Block Diagram of Interrupt

### 14.1 Interrupt priority and sources

Each interrupt vector is independent and has its own priority. Software interrupt (BRK) is also available. Interrupt

source classification is shown in Table 14-1.

### 14.2 Interrupt control register

I flag of PSW is a interrupt mask enable flag. When I flag = “0”, all interrupts become disable. When I flag = “1”, interrupts can be selectively enabled and disabled by contents of corresponding Interrupt Enable Register. When interrupt is occurred, interrupt request flag is set, and Interrupt request is detected at the edge of interrupt signal. The accepted interrupt request flag is automatically cleared

during interrupt cycle process. The interrupt request flag maintains “1” until the interrupt is accepted or is cleared in program. In reset state, interrupt request flag register (IRQH, IRQL) is cleared to “0”. It is possible to read the state of interrupt register and to manipulate the contents of register and to generate interrupt. (Refer to software interrupt)

	Mask	Priority	Reset/Interrupt	Symbol	INT Vector H	INT Vector L
Hardware Interrupt	Non-maskable	-	Hardware Reset	$\overline{\text{RESET}}$	FFFF	FFFE
	maskable	1	Key Scan	KSCNR	FFFB	FFFA
		2	External Interrupt1	INT1R	FFF9	FFF8
		3	External Interrupt2	INT2R	FFF7	FFF6
		4	Timer0	T0R	FFF3	FFF2
		5	Timer1	T1R	FFF1	FFF0
		6	Timer2	T2R	FFE9	FFE8
		7	Watch Dog Timer	WDTR	FFE7	FFE6
8	Basic Interval Timer	BITR	FFDF	FFDE		
Software Interrupt	-	-	BRK Instruction	BRK	FFDF	FFDE

Table 14-1 Interrupt Source

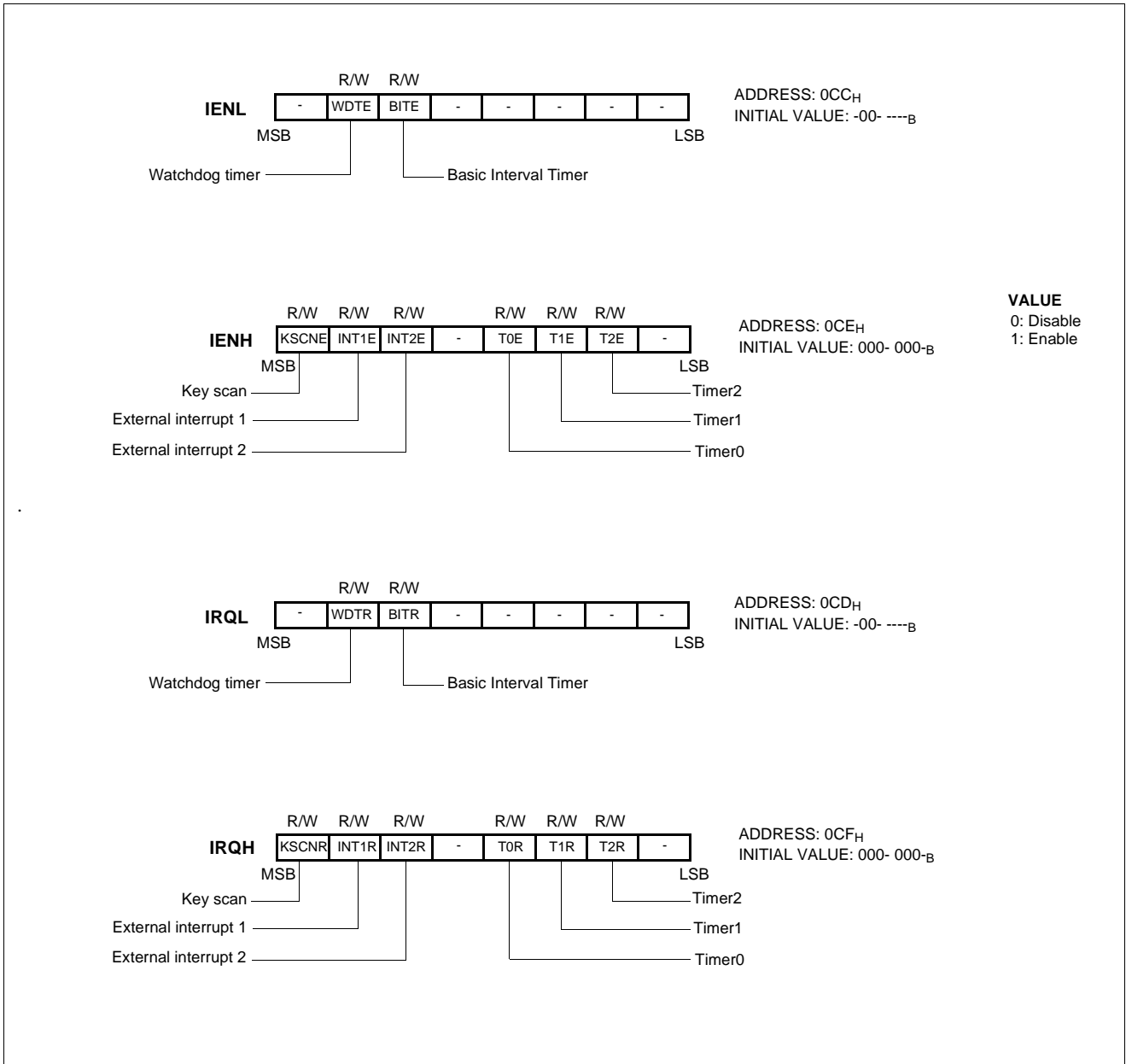
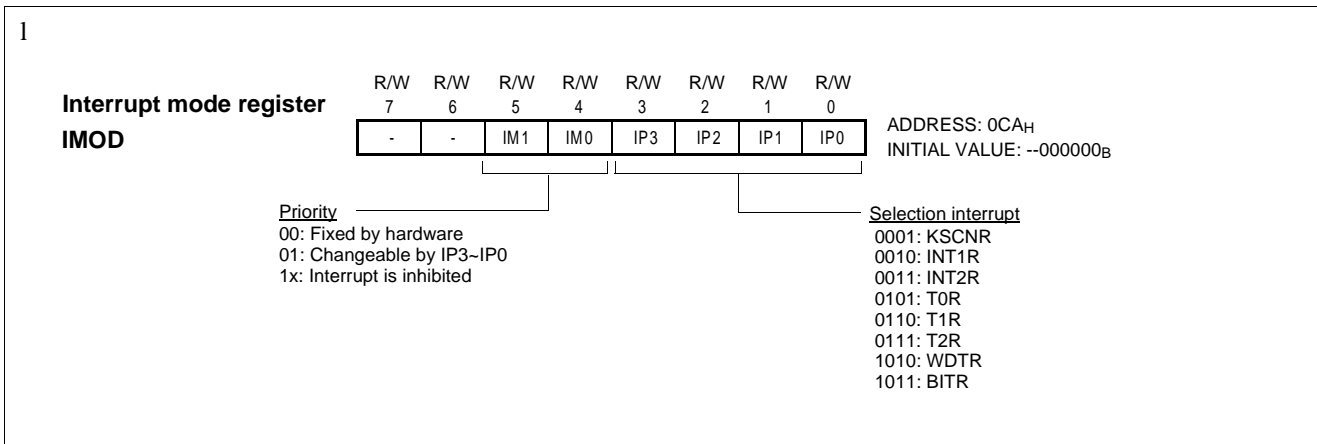

Figure 14-2 Interrupt Enable & Request Flag

### 14.3 Interrupt accept mode

The interrupt priority order is determined by bit (IM1, IM0) of IMOD register. The condition allow for accepting interrupt is set state of the interrupt mask enable flag and

the interrupt enable bit must be “1”. In Reset state, these IP3 - IP0 registers become all “0”.



**Figure 14-3 Interrupt Accept Mode & Selection by IP3~IP0**

### 14.4 Interrupt Sequence

An interrupt request is held until the interrupt is accepted or the interrupt latch is cleared to “0” by a reset or an instruction. Interrupt acceptance sequence requires 8 f<sub>XIN</sub> after the completion of the current instruction execution. The interrupt service task is terminated upon execution of an interrupt return instruction [RETI].

#### Interrupt acceptance

1. The interrupt master enable flag (I-flag) is cleared to “0” to temporarily disable the acceptance of any following maskable interrupts. When a non-maskable interrupt is accepted, the acceptance of any following interrupts is temporarily disabled.

2. Interrupt request flag for the interrupt source accepted is cleared to “0”.
3. The contents of the program counter (return address) and the program status word are saved (pushed) onto the stack area. The stack pointer decreases 3 times.
4. The entry address of the interrupt service program is read from the vector table address and the entry address is loaded to the program counter.
5. The instruction stored at the entry address of the interrupt service program is executed.

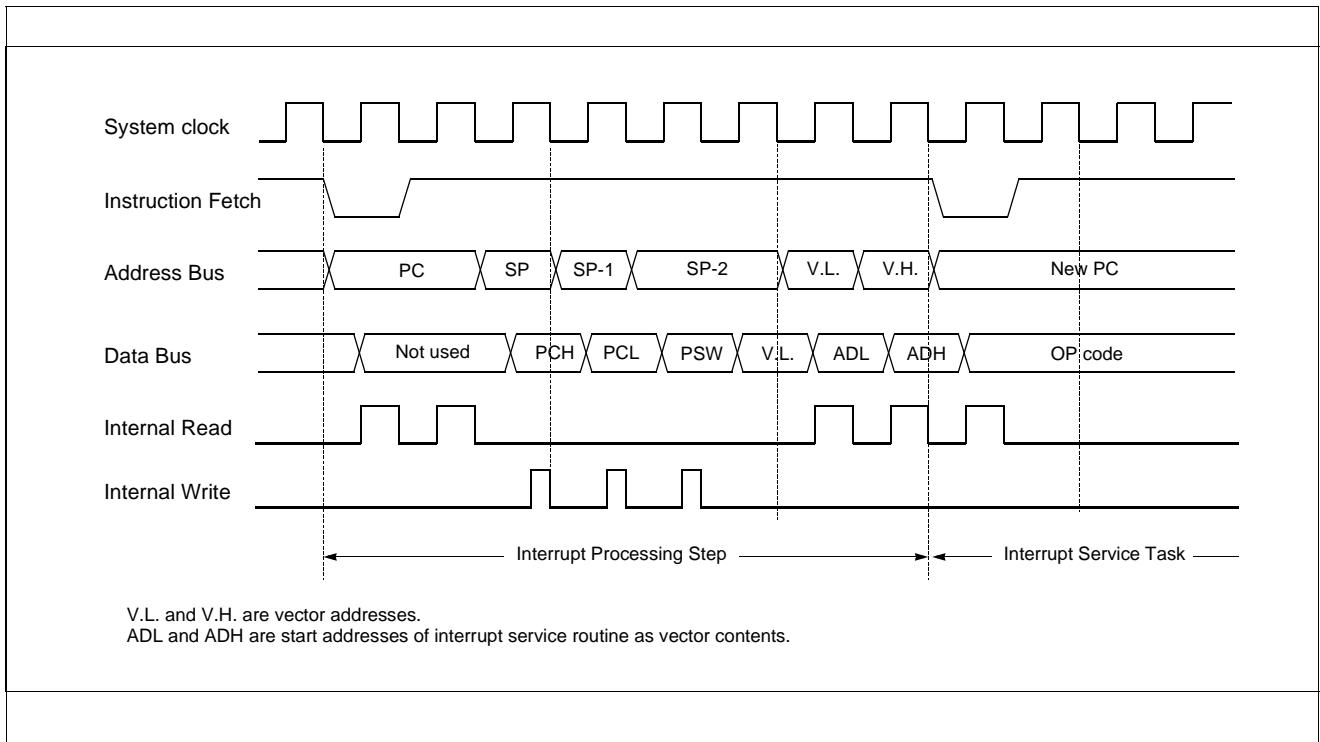
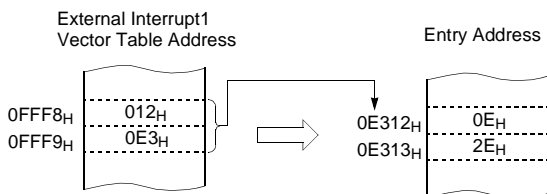

Figure 14-4 Timing chart of Interrupt Acceptance and Interrupt Return Instruction



Correspondence between vector table address for External Interrupt1 and the entry address of the interrupt service program.

A interrupt request is not accepted until the I-flag is set to “1” even if a requested interrupt has higher priority than that of the current interrupt being serviced.

When nested interrupt service is required, the I-flag should be set to “1” by “EI” instruction in the interrupt service program. In this case, acceptable interrupt sources are selectively enabled by the individual interrupt enable flags.

### Saving/Restoring General-purpose Register

During interrupt acceptance processing, the program counter and

the program status word are automatically saved on the stack, but accumulator and other registers are not saved itself. These registers are saved by the software if necessary. Also, when multiple interrupt services are nested, it is necessary to avoid using the same data memory area for saving registers.

The following method is used to save/restore the general-purpose registers.

Example: Register save using push and pop instructions

```
INTxx:  PUSH   A      ;SAVE ACC.
        PUSH   X      ;SAVE X REG.
        PUSH   Y      ;SAVE Y REG.
```

interrupt processing

```
POP     Y      ;RESTORE Y REG.
POP     X      ;RESTORE X REG.
POP     A      ;RESTORE ACC.
RETI
```

General-purpose register save/restore using push and pop instructions;

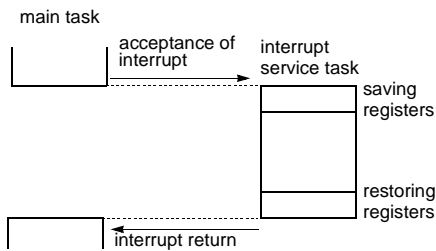

### 14.5 BRK Interrupt

Software interrupt can be invoked by BRK instruction, which has the lowest priority order.

Interrupt vector address of BRK is shared with the vector of TCALL 0 (Refer to Program Memory Section). When BRK interrupt is generated, B-flag of PSW is set to distinguish BRK from TCALL 0.

Each processing step is determined by B-flag as shown in Figure 14-5

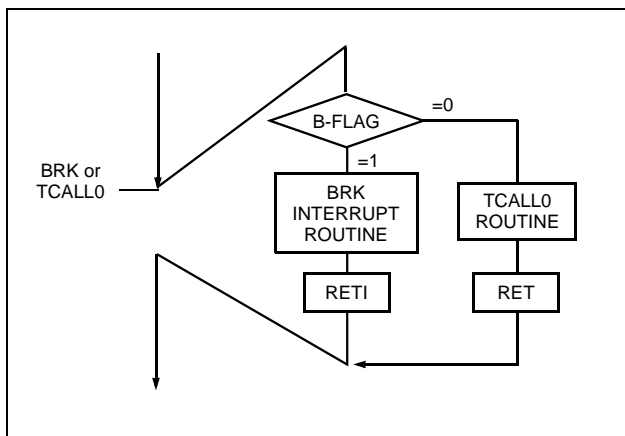

Figure 14-5 Execution of BRK/TCALL0

### 14.6 Multi Interrupt

If two requests of different priority levels are received simultaneously, the request of higher priority level is serviced. If requests of the interrupt are received at the same time simultaneously, an internal polling sequence determines by hardware which request is serviced.

### 14.7 External Interrupt

The external interrupt on INT1 and INT2 pins are edge triggered depending on the edge selection register IEDS (address 0D8H) as

However, multiple processing through software for special features is possible. Generally when an interrupt is accepted, the I-flag is cleared to disable any further interrupt. But as user sets I-flag in interrupt routine, some further interrupt can be serviced even if certain interrupt is in progress.

**Example:** During Timer1 interrupt is in progress, INT1 interrupt serviced without any suspend.

```

TIMER1:  PUSH  A
         PUSH  X
         PUSH  Y
         LDM   IENH,#40H ; Enable INT1 only
         LDM   IENL,#00H ; Disable other
         EI    ; Enable Interrupt
         :
         :
         :
         :
         LDM   IENH,#0FFH ; Enable all interrupts
         LDM   IENL,#0FFH
         POP   Y
         POP   X
         POP   A
         RETI
    
```

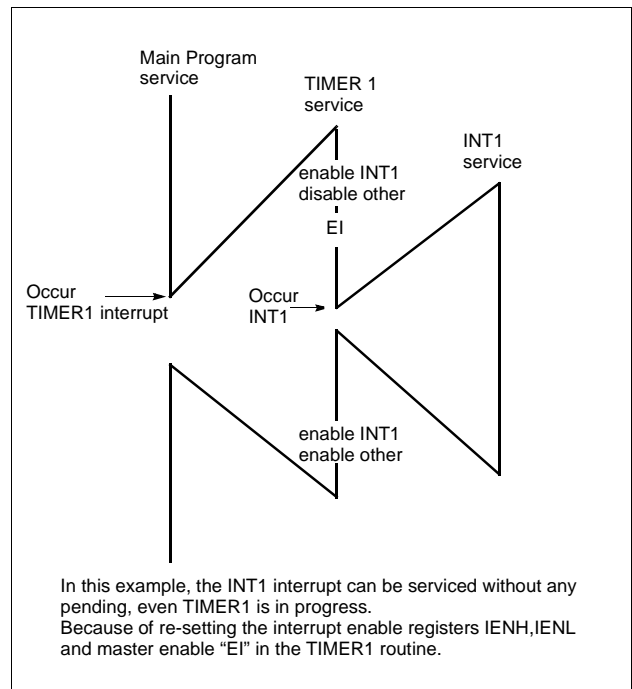

Figure 14-6 Execution of Multi Interrupt

shown in Figure14-7.

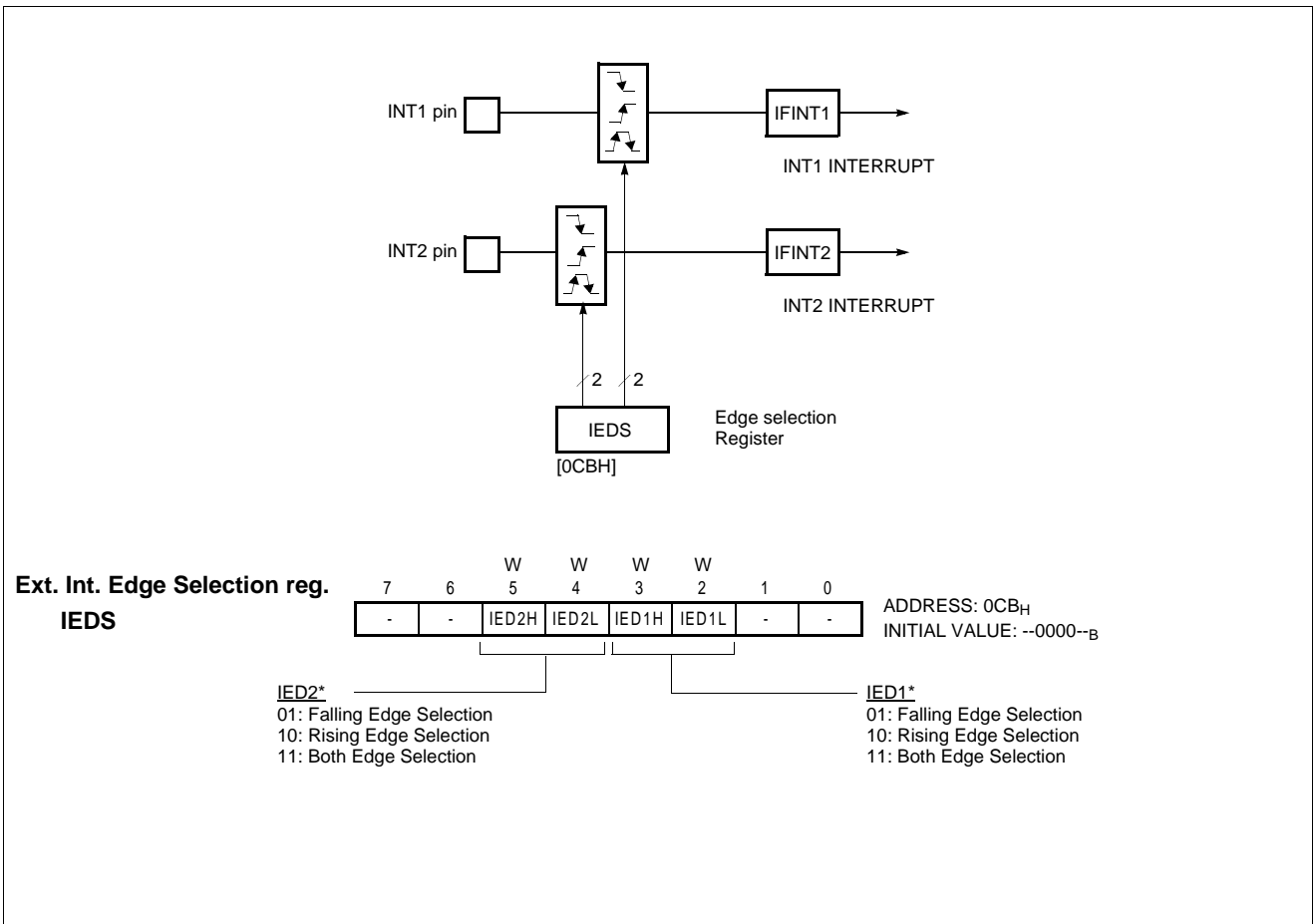

Figure 14-7 External Interrupt Block Diagram

**Response Time**

The INT1 ~ INT2 edge are latched into IFINT1 ~ IFINT2 at every machine cycle. The values are not actually polled by the circuitry until the next machine cycle. If a request is active and conditions are right for it to be acknowledged, a hardware subroutine call to the requested service routine will be the next instruction to be executed. The DIV itself takes twelve cycles. Thus, a minimum of twelve complete machine cycles elapse between activation of an external interrupt request and the beginning of execution of the first instruction of the service routine.

Figure 14-8 shows interrupt response timings.

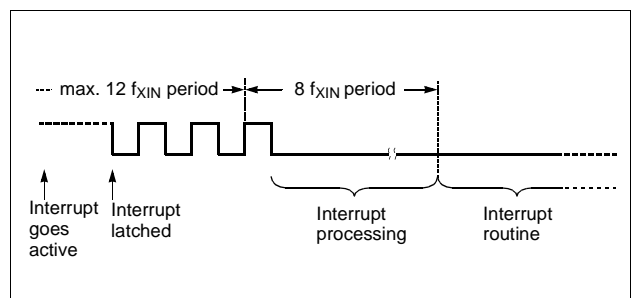

Figure 14-8 Interrupt Response Timing Diagram

**14.8 Key Scan Input Processing**

Key Scan Interrupt is generated by detecting low or high Input from each Input pin (R0, R1) is one of the sources which release standby (SLEEP, STOP) mode. Key Scan ports are all 16bit which are controlled by Standby Mode Release Register (SMRR0, SMRR1). Key Input is considered as Interrupt, therefore, KSCNE bit of IEHN should be

set for correct interrupt executing, SLEEP mode and STOP mode, the rest of executing is the same as that of external Interrupt. Each SMRR Register bit is allowed for each port (for Bit= "0", no Key Input, for Bit= "1", Key Input available). At reset, SMRR becomes "00h". So, there is no Key Input source.

Standby release level control register (SRLC) can select the key scan input level “L” or “H” for standby release by each bit pin (R0, R1). Standby release level control register

(SRLC) is write-only register and initialized as “00h” in reset state.

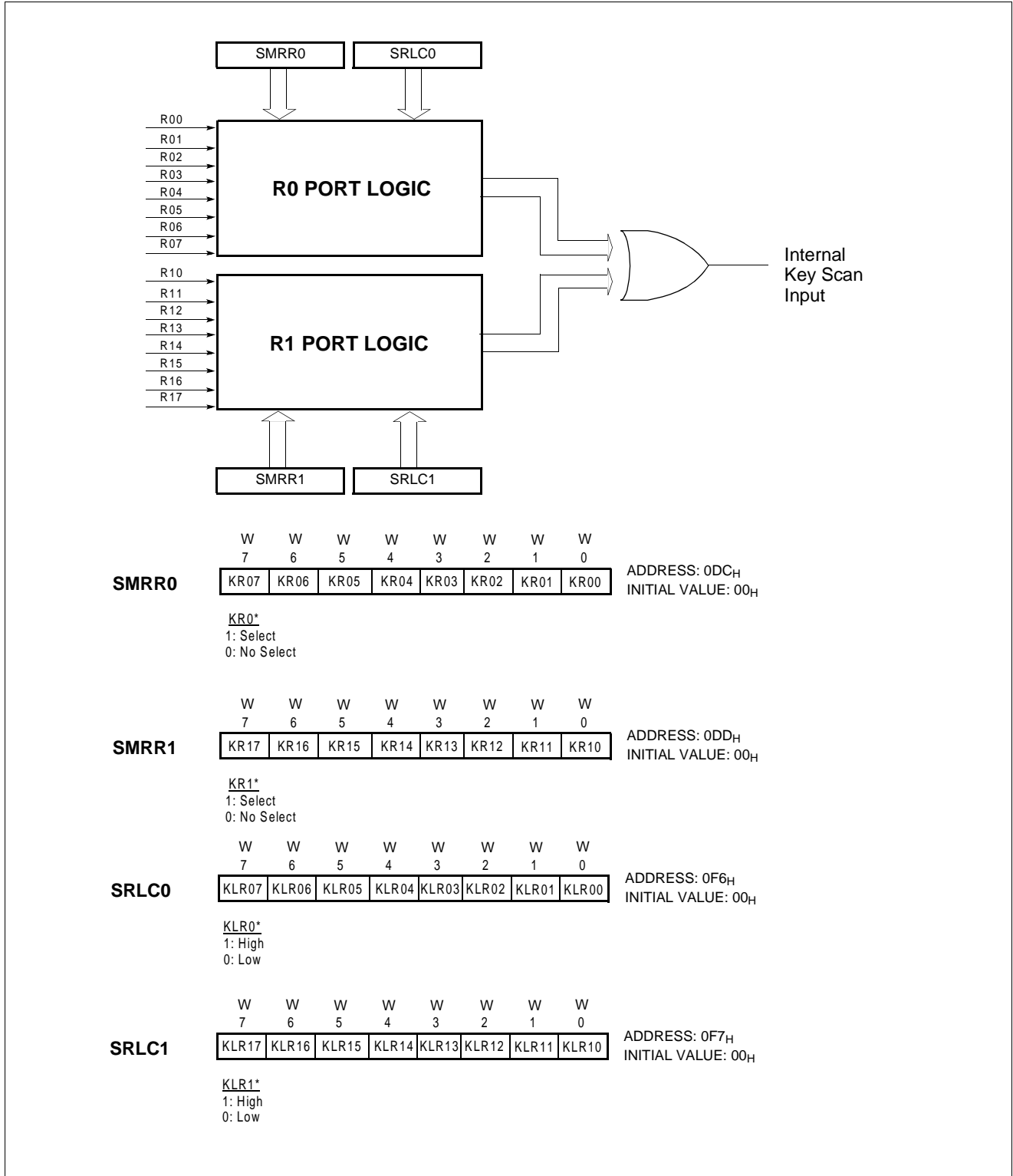

Figure 14-9 Block Diagram of Key Scan Block

## 15. STANDBY FUNCTION

### 15.1 Sleep Mode

SLEEP mode can be entered by setting the bit of SLEEP mode register (SLPM). In the mode, CPU clock stops but oscillator keeps running. B.I.T and a part of peripheral hardware execute, but prescaler output which provide clock to peripherals can be stopped by program. (Except, PS10 can't stopped.) In SLEEP mode, more consuming power can be saved by not using other peripheral hardware except for B.I.T. By setting ENPCK (peripheral clock control bit) of CKCTLR (clock control register) to "0", peripheral hardware halted, and SLEEP mode is entered. To release SLEEP mode by B.I.T (basic interval timer interrupt), bit10 of prescaler should be selected as B.I.T input clock before entering SLEEP mode. "NOP" instruction should be follows setting of SLEEP mode for rising pre-charge time of data bus line.

(ex) setting of SLEEP mode : set the bit of SLEEP  
 ; mode register (SLPM)  
 NOP : NOP instruction

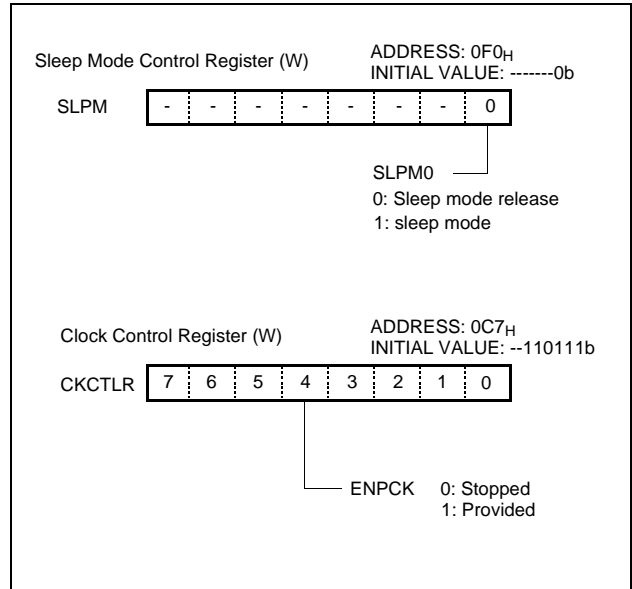

### 15.2 Stop Mode

STOP mode can be entered by STOP instruction during program. In STOP mode, oscillator is stopped to make all clocks stop, which leads to less power consumption. All registers and RAM data are preserved. "NOP" instruction should be follows STOP instruction for rising precharge

time of Data Bus line.

(ex) STOP : STOP instruction execution  
 NOP : NOP instruction

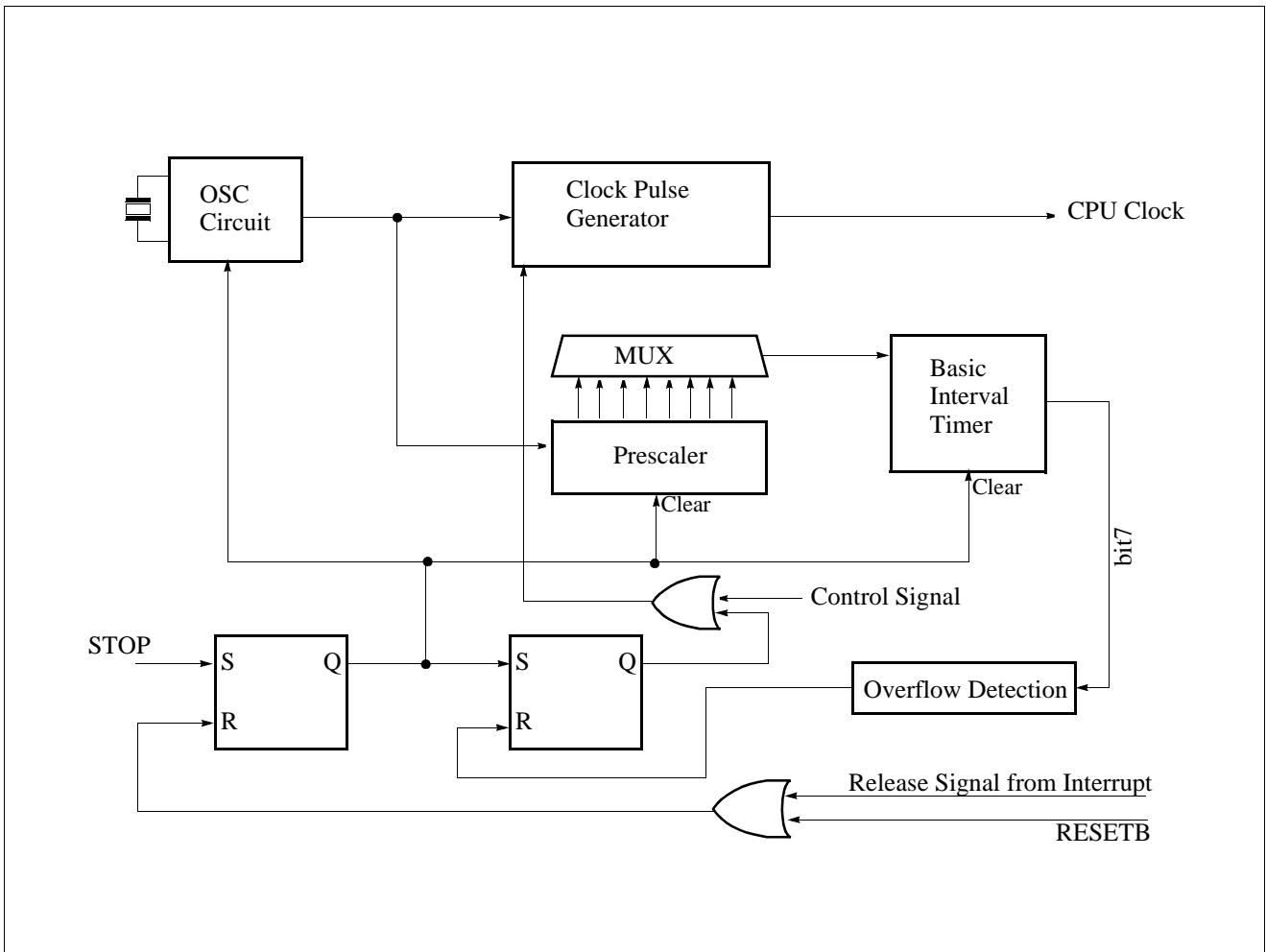

Figure 15-1 Block Diagram of Standby Circuit

### 15.3 Standby mode release

Release of STANDBY mode is executed by RESET input and Interrupt signal. Register value is defined when Reset. When there is a release signal of STOP mode (Interrupt, RESET input), the instruction execution starts after stabilization oscillation time is set by value of BTS2 ~ BTS0 and set ENPCK to "1".

Release Signal	SLEEP	STOP
RESETB	O	O
KSCN(Key Input)	O	O
INT1,INT2	O	O
B.I.T.	O	X

Table 15-1 Release Signal of Standby Mode

Release Factor	Release Method
RESETB	By RESETB Pin=Low level, Standby mode is released and system is initialized
KSCN(Key Input)	Standby mode is released by low input of selected pin by key scan Input(SMRR0,SMRR1). In case of interrupt mask enable flag= "0", program executes just after standby instruction, if flag= "1" enters each interrupt service routine.
INT1,INT2	When external interrupt (INT1,INT2) enable flag is "1", standby mode is released at the rising edge of each terminal. When standby mode is released at interrupt. Mask Enable flag= "0", program executes from the next instruction of standby instruction. When "1", enters each interrupt service routine.
Basic Interval Timer(IFBIT)	When B.I.T. is executed only by bit10 of prescaler(PS10), SLEEP mode can be released. Interrupt release SLEEP mode, when BIT interrupt enable flag is "1". When standby mode is released at interrupt. Mask enable flag= "0", program executes from the next instruction of SLEEP instruction. When "1", enters each interrupt service routine.

Table 15-2

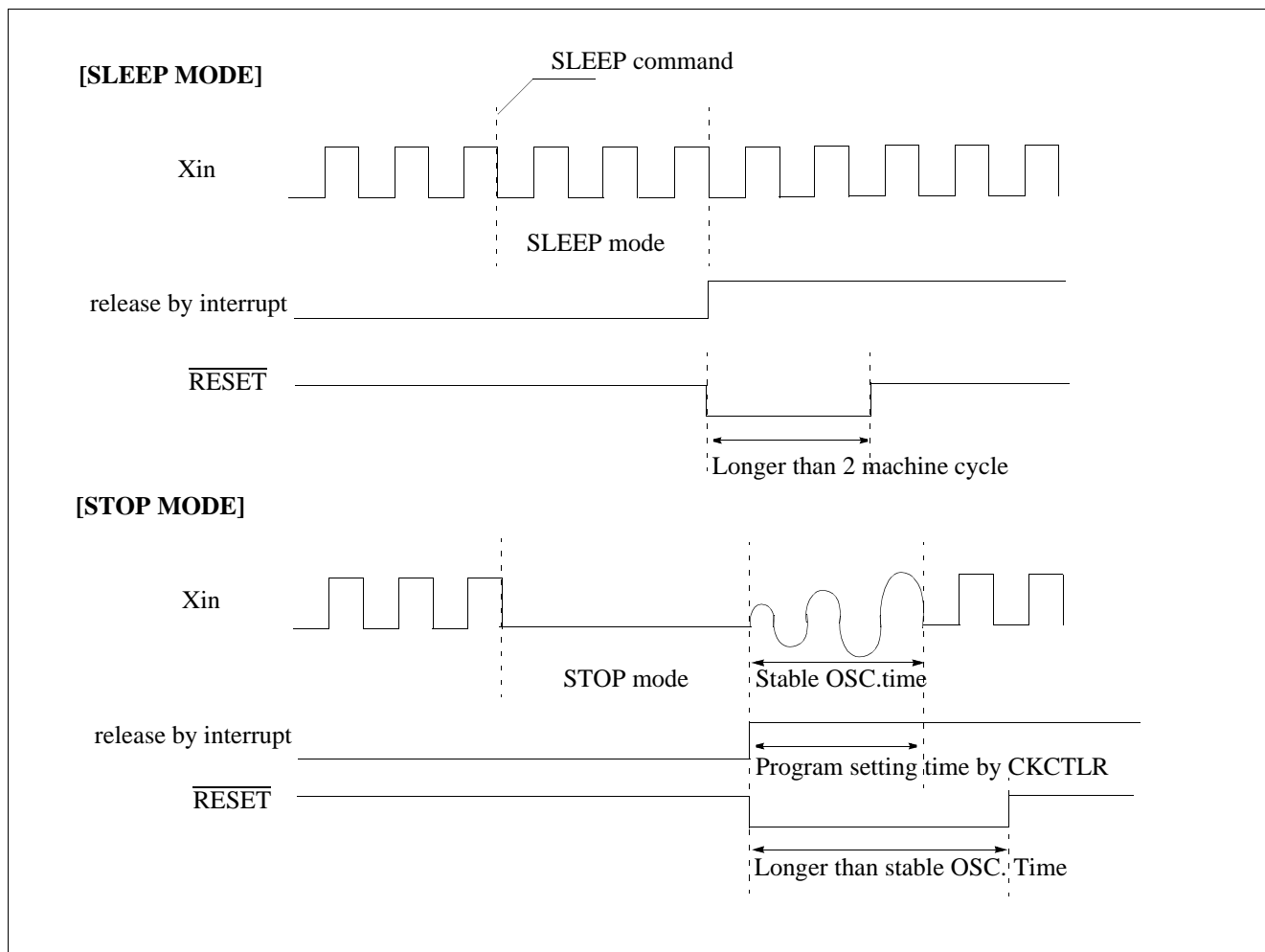

Figure 15-2 Block Diagram of Standby Circuit

### 15.4 Operation of standby mode release

After standby mode is released, the operation begins according to content of related interrupt register just before

standby mode start (Figure 15-3).

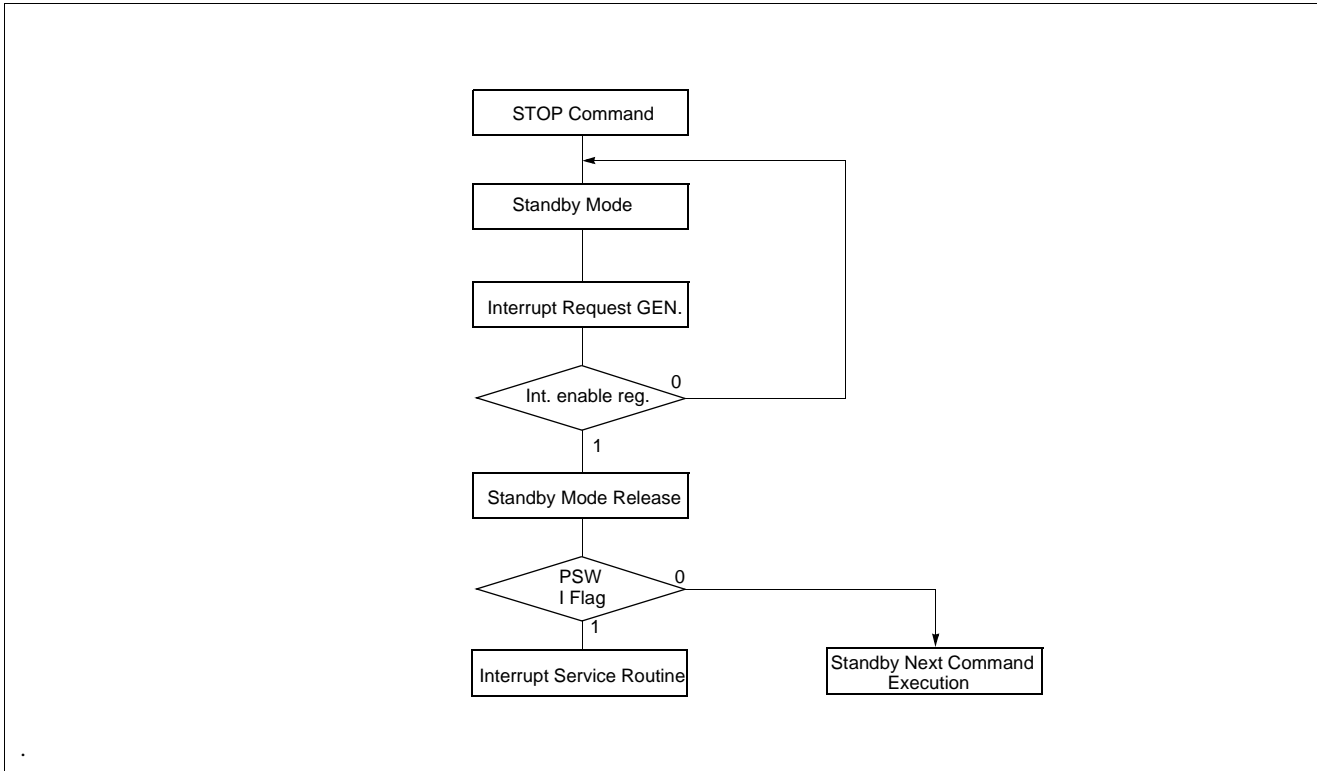

Figure 15-3 Standby Mode Release Flow

**(1) Interrupt Enable Flag(I) of PSW = “0”**

Release by only interrupt which interrupt enable flag = “1”, and starts to execute from next to standby instruction (SLEEP or STOP).

**(2) Interrupt Enable Flag(I) of PSW = “1”**

Released by only interrupt which each interrupt enable flag = “1”, and jump to the relevant interrupt service routine.

*tering STOP mode, clock of bit10 (PS10) of prescaler is selected or peripheral hardware clock control bit (ENPCK) to “1”, Therefore the clock necessary for stabilization oscillation time should be input into B.I.T. otherwise, standby mode is released by reset signal. In case of interrupt request flag and interrupt enable flag are both “1”, standby mode is not entered.*

**Note:** When STOP instruction is used, B.I.T should guarantee the stabilization oscillation time. Thus, just before en-

Internal circuit	SLEEP mode	STOP mode
Oscillator	Active	Stop
Internal CPU	Stop	Stop
Register	Retained	Retained
RAM	Retained	Retained
I/O port	Retained	Retained
Prescaler	Active	Stop
Basic Interval Timer	PS10 selected:Active Others: Stop	Stop
Watch-dog Timer	Stop	Stop
Timer	Stop	Stop
Address Bus,Data Bus	Retained	Retained

**Table 15-3 Operation State in Standby Mode**

## 16. RESET FUNCTION

### 16.1 External RESET

The  $\overline{\text{RESET}}$  pin should be held at low for at least 2 machine cycles with the power supply voltage within the operating voltage range and must be connected 0.1uF capacitor for

stable system initialization. The RESET pin contains a Schmitt trigger with an internal pull-up resistor.

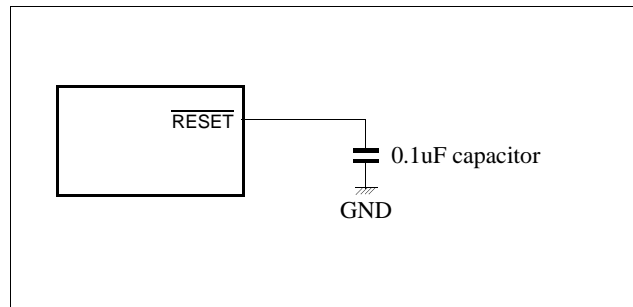

Figure 16-1  $\overline{\text{RESET}}$  Pin connection

### 16.2 Power on RESET

Power On Reset circuit automatically detects the rise of power voltage (the rising time should be within 50ms) the power voltage reaches a certain level, RESET terminal is maintained at “L” Level until a crystal ceramic oscillator oscillates stably. After power applies and starting of oscillation, this reset state is maintained for about oscillation cycle of 219 (about 65.5ms: at 4MHz).The execution of built-in Power On Reset circuit is as follows:

(1) Latch the pulse from Power On Detection Pulse Generator circuit, and reset Prescaler, B.I.T and B.I.T Overflow

detection circuit.

(2) Once B.I.T Overflow detection circuit is reset. Then, Prescaler starts to count.

(3) Prescaler output is inputted into B.I.T and PS10 of Prescaler output is automatically selected. If overflow of B.I.T is detected, Overflow detection circuit is set.

4) Reset circuit generates maximum period of reset pulse from Prescaler and B.I.T

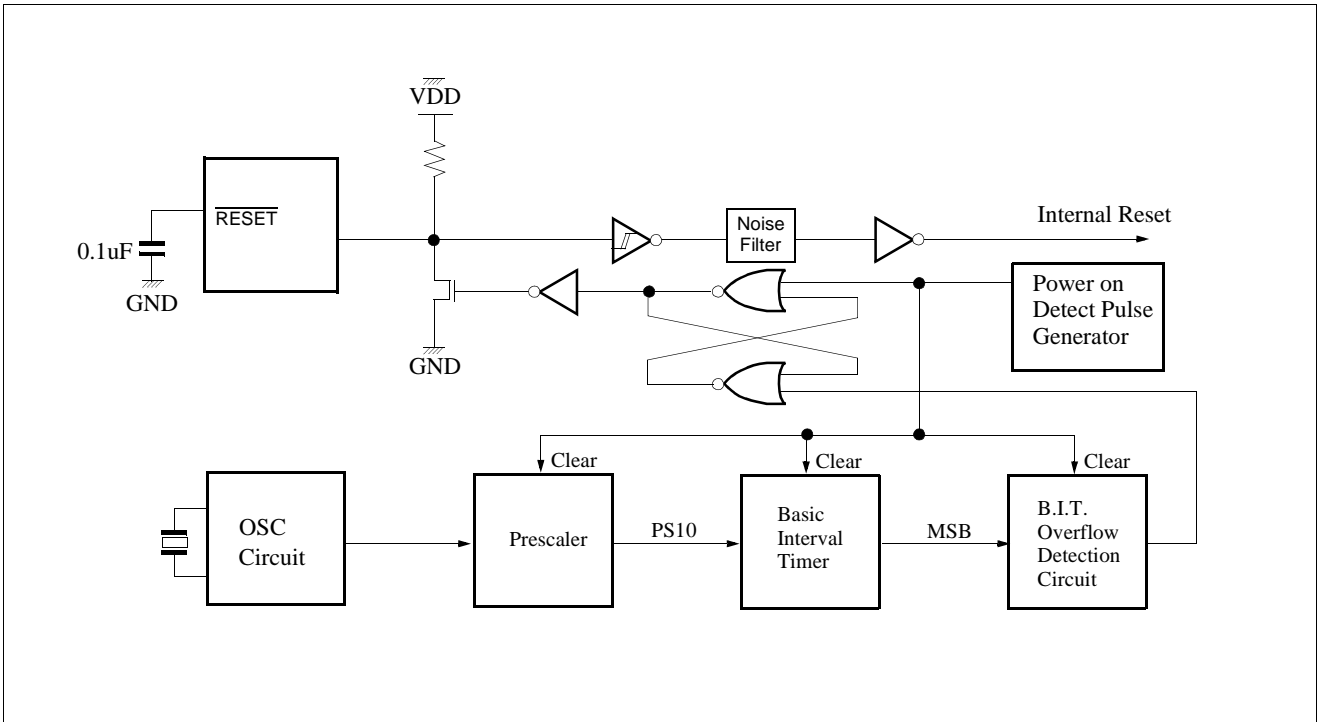

Figure 16-2 Block Diagram of Power On Reset Circuit

**Note:** When Power On Reset, oscillator stabilization time doesn't include OSC. Start time.

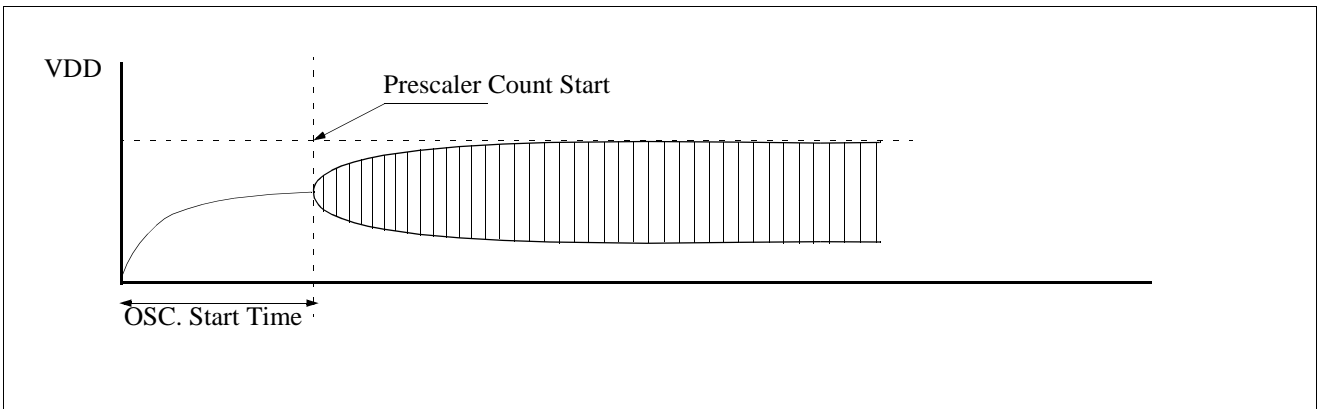

Figure 16-3 Oscillator stabilization diagram

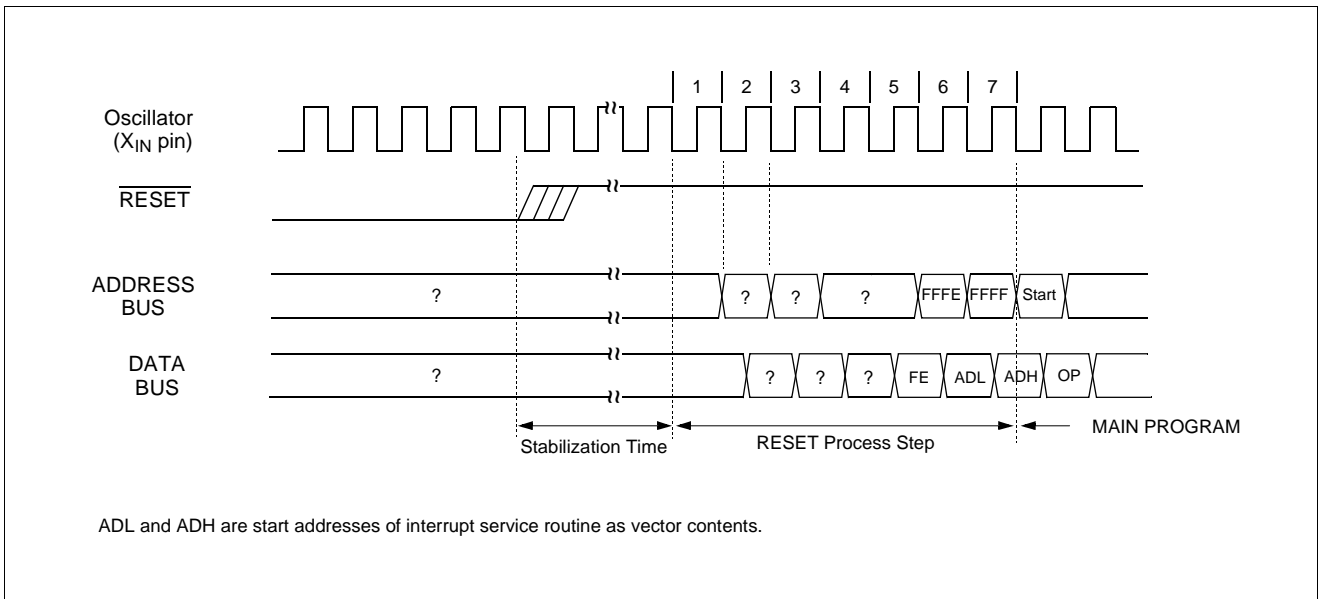

Figure 16-4 Timing Diagram of Reset

### 16.3 Low voltage detection mode

#### (1) Low voltage detection condition

An on board voltage comparator checks that VDD is at the required level to ensure correct operation of the device. If VDD is below a certain level, Low voltage detector forces the device into low voltage detection mode.

#### (2) Low Voltage Detection Mode

There is no power consumption except stop current, stop mode release function is disabled. All I/O port is configured as input mode and Data memory is retained until voltage through external capacitor is worn out. In this mode,

all port can be selected with Pull-up resistor by Mask option. If there is no information on the Mask option sheet, the default pull up option (all port connect to pull-up resistor) is selected.

#### (3) Release of Low Voltage Detection Mode

Reset signal result from new battery (normally 3V) wakes the low voltage detection mode and come into normal reset state. It depends on user whether to execute RAM clear routine or not

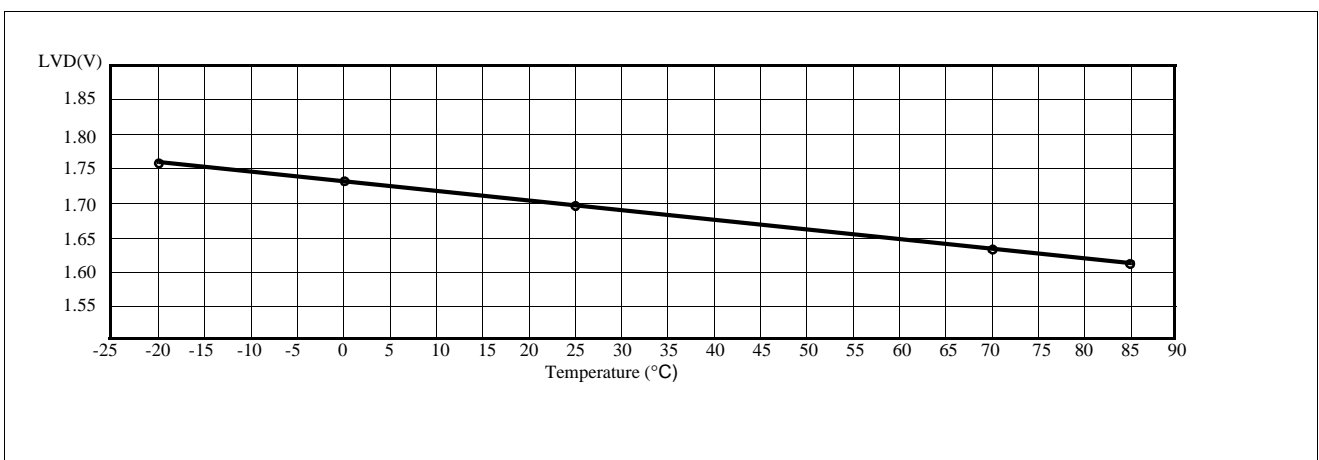
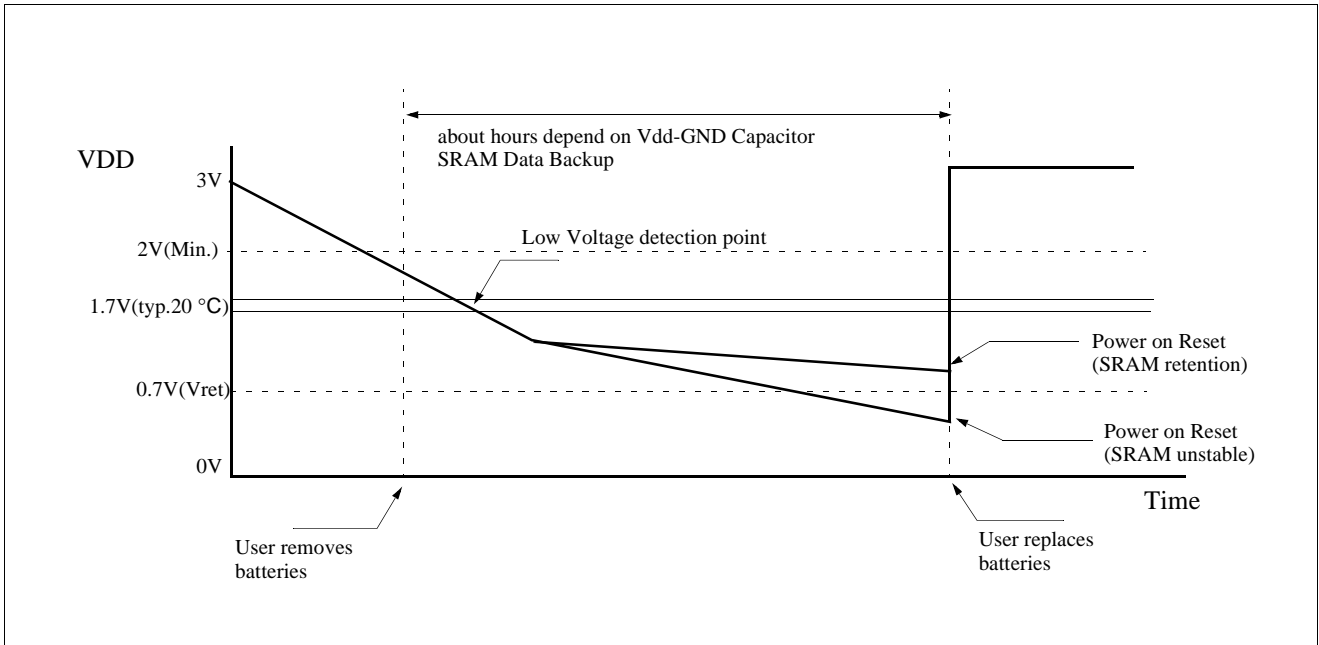

Figure 16-5 Low Voltage vs Temperature

**(4) SRAM BACK-UP after Low Voltage Detection.**



**Figure 16-6 Oscillator stabilizing diagram**

Interrupt	disable
Stop release	disable
All I/O port	input Mode
Remout port	Low Level
OSC	STOP
All I/O port pull-up on	Mask Option
SRAM Data	retention until Fret

**Table 16-1 The operation after Low Voltage detection**

(5) S/W flow chart example after Reset using SRAM Back-up

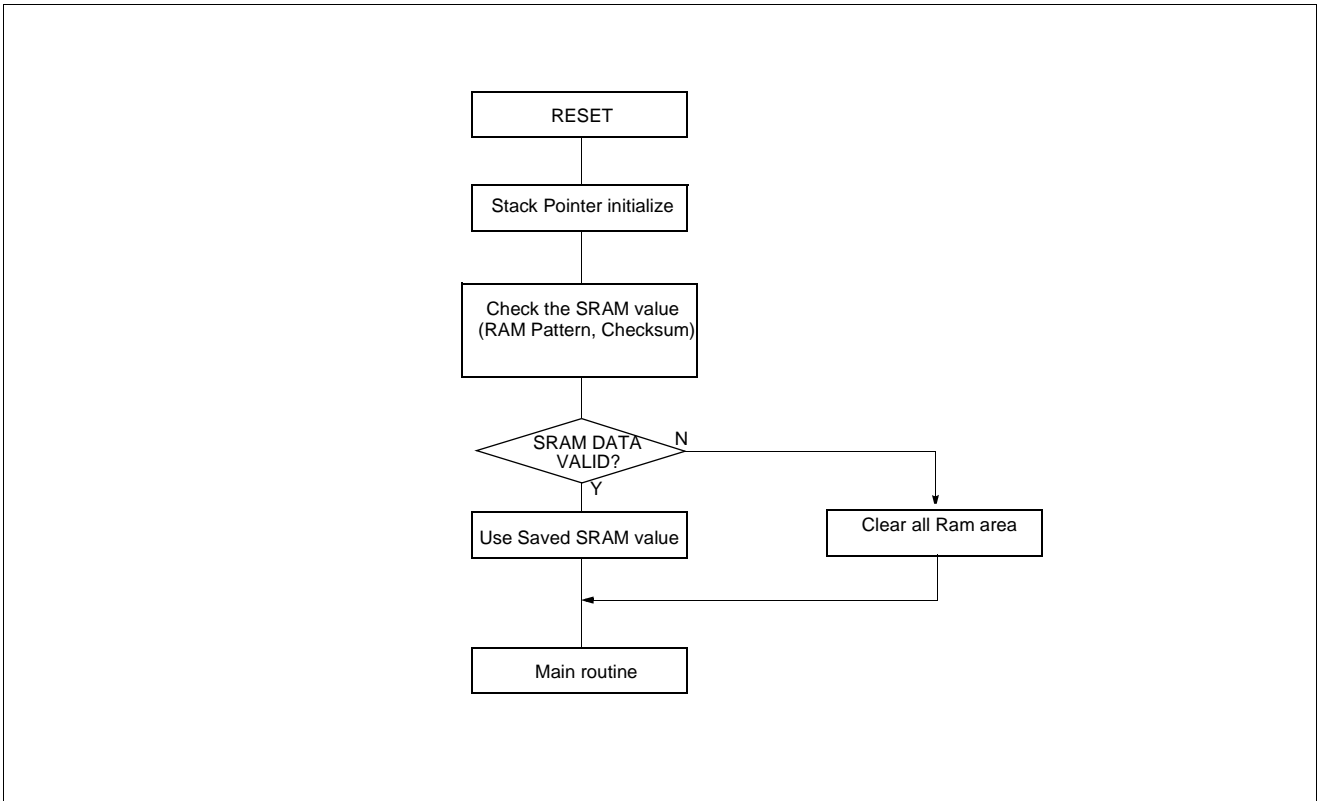

Figure 16-7 S/W flow chart example after Reset using SRAM Back-up



17.2 PROM Mode pin assignment

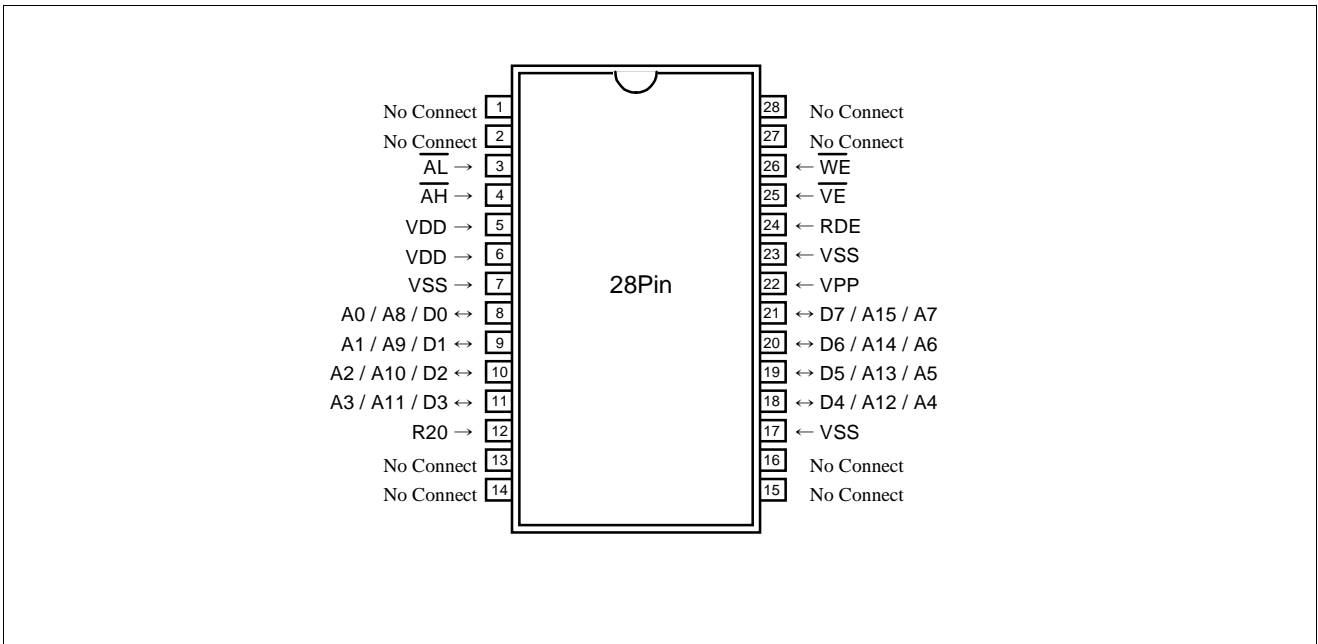

Figure 17-2 pin assignment

### 17.3 Standard Mode Pin Description

Pin Name	Input Output Type	Pin Number				Function	@ RESET	@ STOP
		20Pin	24Pin	28Pin	44Pin			
R00	Input Output	6	8	8	11	<ul style="list-style-type: none"> <li>▶ 8bit CMOS input with pull_up resistor (option).</li> <li>▶ 8bit push-pull output.</li> <li>▶ During output, pull-up resistor is disabled automatically.</li> <li>▶ Programmable key scan Input function.</li> </ul>	Input	Remain
R01		7	9	9	15			
R02		8	10	10	16			
R03		9	11	11	19			
R04		12	14	18	27			
R05		13	15	19	30			
R06		14	16	20	31			
R07	15	17	21	32				
R10	Input Output	2	4	21	5	<ul style="list-style-type: none"> <li>▶ 8bit CMOS input with pull_up resistor (option).</li> <li>▶ 8bit push-pull output.</li> <li>▶ During output, pull-up resistor is disabled automatically.</li> <li>▶ Programmable key scan Input function.</li> <li>▶ LED driver : include N-TR</li> <li>▶ Programmable open drain output</li> </ul>	Input	Remain
R11/ INT1		1	3	3	4			
R12/ INT2		---	2	2	3			
R13		---	1	1	2			
R14 / $\overline{EC}$		---	24	28	44			
R15/T2		---	23	27	43			
R16/T1		20	22	26	42			
R17/T0	19	21	25	41				
R20	Input Output	10	12	12	20	<ul style="list-style-type: none"> <li>▶ 8bit CMOS input with pull_up resistor (option).</li> <li>▶ 8bit push-pull output.</li> <li>▶ During output, pull-up resistor is disabled automatically.</li> <li>▶ LED driver : include N-TR</li> </ul>	Input	Remain
R21		---	---	13	21			
R22		---	---	14	22			
R23		---	---	15	24			
R24		---	---	16	25			
R25		---	---	---	13			
R26		---	---	---	14			
R27	---	---	---	36				
XIN	Input	5	7	7	10	Oscillator Input		Low
XOUT	Output	4	6	6	9	Oscillator Output		High
REMOUT	Output	18	20	24	38	Remocon signal output pin Large current output capability	Low level output	Low level output
$\overline{RESET}$	Input	17	19	23	37	Low Active, include pull-up resistor, External capacitor needed (0.1uF)	Low level	Remain
$\overline{TEST}$	Input	16	18	22	33	Low Active, include pull-up resistor		Remain
VDD	Power	3	5	5	8	Positive Power Supply		
VSS	Power	11	13	17	26	Ground		
VSS	Power	---	---	---	35			

**17.4 PROM Mode Pin Description**

28Pin Number	Standard Mode Pin Name	EPROM Mode Pin Name	Input Output Type	Function
1	R13			No Connection
2	R12			No Connection
3	R11	$\overline{AL}$	Input	Address Low Input Enable
4	R10	$\overline{AH}$	Input	Address High Input Enable
5	VDD	VDD	Power	Positive Power Supply
6	XOUT	VDD	Power	
7	XIN	VSS	Power	Ground
8	R00	A0/A8/D0	Input Output	<ul style="list-style-type: none"> <li>▶ Input Mode : Address 3-0</li> <li style="padding-left: 20px;">: Address 11-8</li> <li>▶ Output Mode : Data 3-0</li> </ul>
9	R01	A1/A9/D1		
10	R02	A2/A10/D2		
11	R03	A3/A11/D3		
12	R20	R20	Input	---
13	R21			No Connection
14	R22			No Connection
15	R23			No Connection
16	R24			No Connection
17	VSS	VSS	Power	Ground
18	R04	A4/A12/D4	Input Output	<ul style="list-style-type: none"> <li>▶ Input Mode : Address 7-4</li> <li style="padding-left: 20px;">: Address 15-12</li> <li>▶ Output Mode : Data 7-4</li> </ul>
19	R05	A5/A13/D5		
20	R06	A6/A14/D6		
21	R07	A7/A15/D7		
22	$\overline{TEST}$	VPP	Input	Program Voltage
23	$\overline{RESET}$	VSS	Power	Ground
24	REMOUT	RDE	Input	Read Enable
25	R17	$\overline{VE}$	Input	Verify Enable
26	R16	$\overline{WE}$	Input	Program Enable
27	R15			No Connection
28	R14			No Connection

## 17.5 EPROM Mode

### Mode setting during power up

Mode setting	VPP	RDE	MS	$\overline{VE}$	$\overline{WE}$	$\overline{AL}$	$\overline{AH}$
PROM Write & Verify	11.5V	H	H	H	H	H	H
PROM Verify or Read	11.5V	H	H	H	H	H	H
LOCK Bit Write	11.5V	H	L	H	H	H	H
LOCK Bit Read	11.5V	H	L	H	H	H	H
ROM Size Write	11.5V	H	L	H	H	H	H
ROM Size Read	11.5V	H	L	H	H	H	H

### Mode setting after power up

Mode setting	VPP	RDE	MS	$\overline{VE}$	$\overline{WE}$	$\overline{AL}$	$\overline{AH}$	Remark
PROM Write & Verify	11.5V	L	H	H	H	H	L	Address High Latch
				H	H	L	H	Address Low Latch
				H	L	H	H	PROM Write
				L	H	H	H	PROM Verify
PROM Verify or Read	11.5V	L	H	H	H	H	L	Address High Latch
				H	H	L	H	Address Low Latch
				L	H	H	H	PROM Verify or Read
LOCK Bit Write	11.5V	L	L	H	H	H	L	R0=6X : LOCK Bit Write Data
				H	L	H	H	Program
LOCK Bit Read	11.5V	L	L	H	H	H	L	R0=6X : LOCK Bit Write Data
				H	H	L	H	LOCK Bit Read (R04 Port is High) (R05 Port is Low)

### Programming DC characteristics

Items	Symbol	Min.	Typ.	Max.	Unit	Test condition
Input high voltage	V <sub>IH</sub>	4.5	V <sub>DD</sub>	V <sub>DD</sub> +0.3	V	-
Input low voltage	V <sub>IL</sub>	-0.1	V <sub>SS</sub>	0.4	V	-
Output high voltage	V <sub>OH</sub>	4.0	-	-	V	I <sub>OH</sub> =2.5mA
Output low voltage	V <sub>OL</sub>	-	-	0.4	V	I <sub>OL</sub> =1mA
VDD current	I <sub>DD</sub>	-	-	100	mA	-
VPP current	I <sub>PP</sub>	-	-	100	mA	$\overline{WE}=V_{IL}$
VDD voltage	V <sub>DD</sub>	4.5	5.0	5.5	V	
VPP voltage	V <sub>PP</sub>	11.2	11.5	11.8	V	-
VSS voltage	V <sub>SS</sub>	0	0	0	V	GROUND Level

### Programming AC characteristics

(V<sub>dd</sub>=5.0V±0.5V, V<sub>pp</sub>=11.5V±0.3V, V<sub>ss</sub>=0V, T<sub>a</sub>=25±5 °C)

Items	Symbol	Min.	Typ.	Max.	Unit
High Address Setup Time	t <sub>AHS</sub>	2	-	-	us
High Address Pulse Width	t <sub>AH</sub>	2	-	-	us
High Address Hold Time	t <sub>AHH</sub>	2	-	-	us
Low Address Setup Time	t <sub>ALS</sub>	2	-	-	us
Low Address Pulse Width	t <sub>AL</sub>	2	-	-	us
Low Address Hold Time	t <sub>ALH</sub>	2	-	-	us
Program Setup Time	t <sub>WES</sub>	2	-	-	us
Program Pulse Width	t <sub>WE</sub>	180	200	220	us
Program Hold Time	t <sub>WEH</sub>	2	-	-	us
Data Out Delay Time	t <sub>VED</sub>	-	-	150	ns
Data Out Time	t <sub>VE</sub>	2	-	-	us
Data Out Floating Time	t <sub>VEF</sub>	-	-	130	ns

**Verify or Read DC characteristics**(V<sub>dd</sub>=5.0V±0.5V, V<sub>pp</sub>=11.5V±0.3V, V<sub>ss</sub>=0V, T<sub>a</sub>=25±5 °C)

Items	Symbol	Min.	Typ.	Max.	Unit	Test condition
VDD Active current	IDD1	-	-	30	mA	$\overline{VE}=V_{IL}$
Input high voltage	V <sub>IH</sub>	V <sub>DD</sub> -0.2	-	V <sub>DD</sub> +0.2	V	
Input low voltage	V <sub>IL</sub>	-0.2	-	0.2	V	
Output high voltage	V <sub>OH</sub>	0.7V <sub>DD</sub>	-	-	V	I <sub>OH</sub> =-2.5mA
Output low voltage	V <sub>OL</sub>	-	-	0.4	V	I <sub>OL</sub> =1mA

**Verify or Read AC characteristics**(V<sub>dd</sub>=5.0V±0.5V, V<sub>pp</sub>=11.5V±0.3V, V<sub>ss</sub>=0V, T<sub>a</sub>=25±5 °C)

Items	Symbol	Min.	Typ.	Max.	Unit
High Address Setup Time	t <sub>AHS</sub>	2	-	-	us
High Address Pulse Width	t <sub>AH</sub>	2	-	-	us
High Address Hold Time	t <sub>AHH</sub>	2	-	-	us
Low Address Setup Time	t <sub>ALS</sub>	2	-	-	us
Low Address Pulse Width	t <sub>AL</sub>	2	-	-	us
Low Address Hold Time	t <sub>ALH</sub>	2	-	-	us
Address Delay Time	t <sub>ADD</sub>	-	-	170	ns
Data Out Delay Time	t <sub>VED</sub>	-	-	150	ns
Data Out Time	t <sub>VE</sub>	2	-	-	us
Data Out Hold Time	t <sub>VEH</sub>	-	-	55	ns
Data Out Floating Time	t <sub>VEF</sub>	0	-	-	ns

### 17.6 Timing Diagram in EPROM Mode

#### EPROM Write & Verify

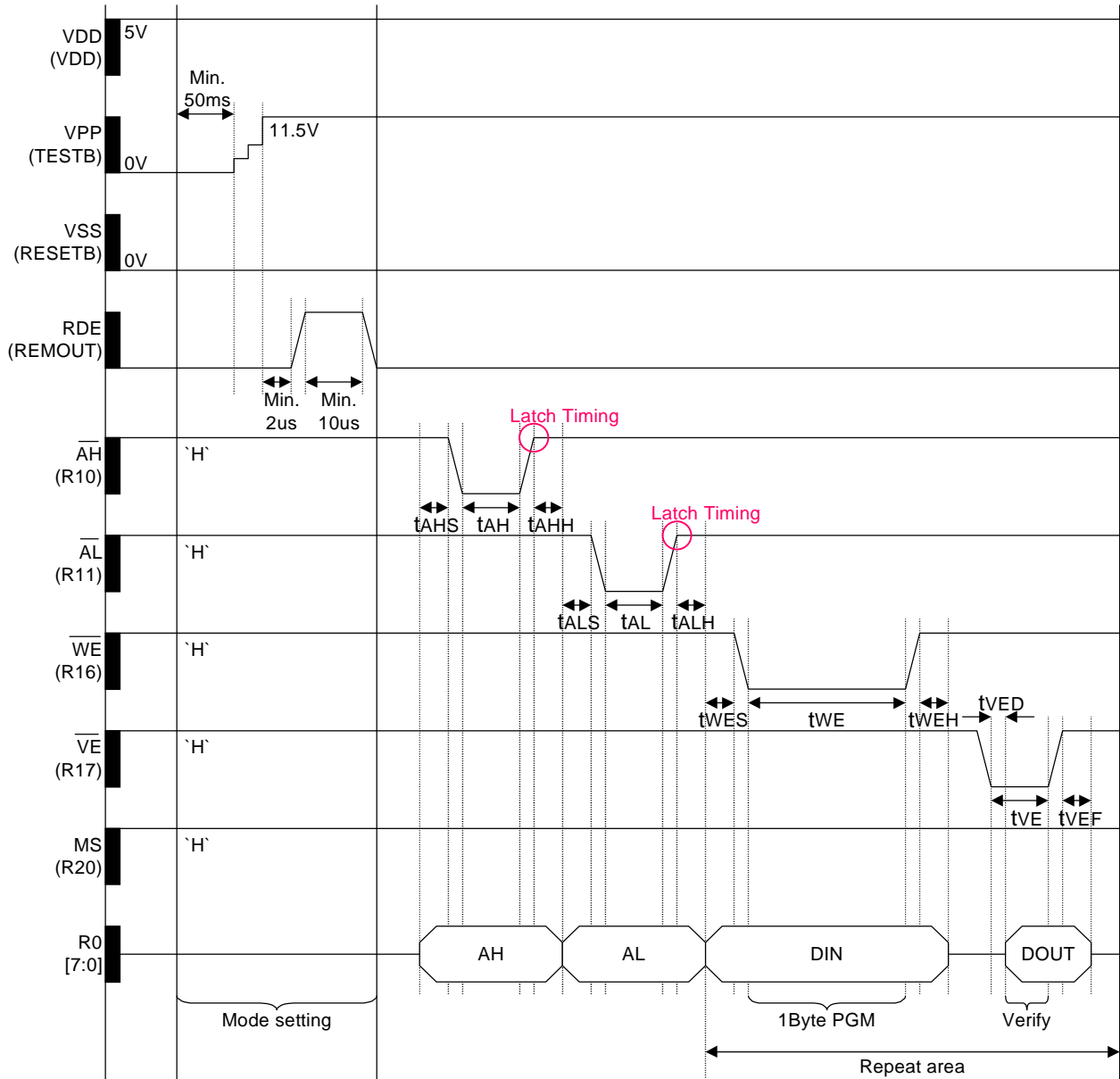

- ※ 1. R0[7:0] address input is latched when AH(R10), AL(R11) is rising.
- 2. R0[7:0] Data out (DOUT) is valid during R17 is 'Low'.
- 3. Writing time (R16 is 'Low') is 200us, and verify data. Maximum repeat count is 20.
- 4. If cell can not be programmed within maximum repeat count, judge as IC is fail.

- ※ AH : High Byte Address Input
- AL : Low Byte Address Input
- DIN : Data Input
- DOUT : Data Output

EPROM Verify or Read

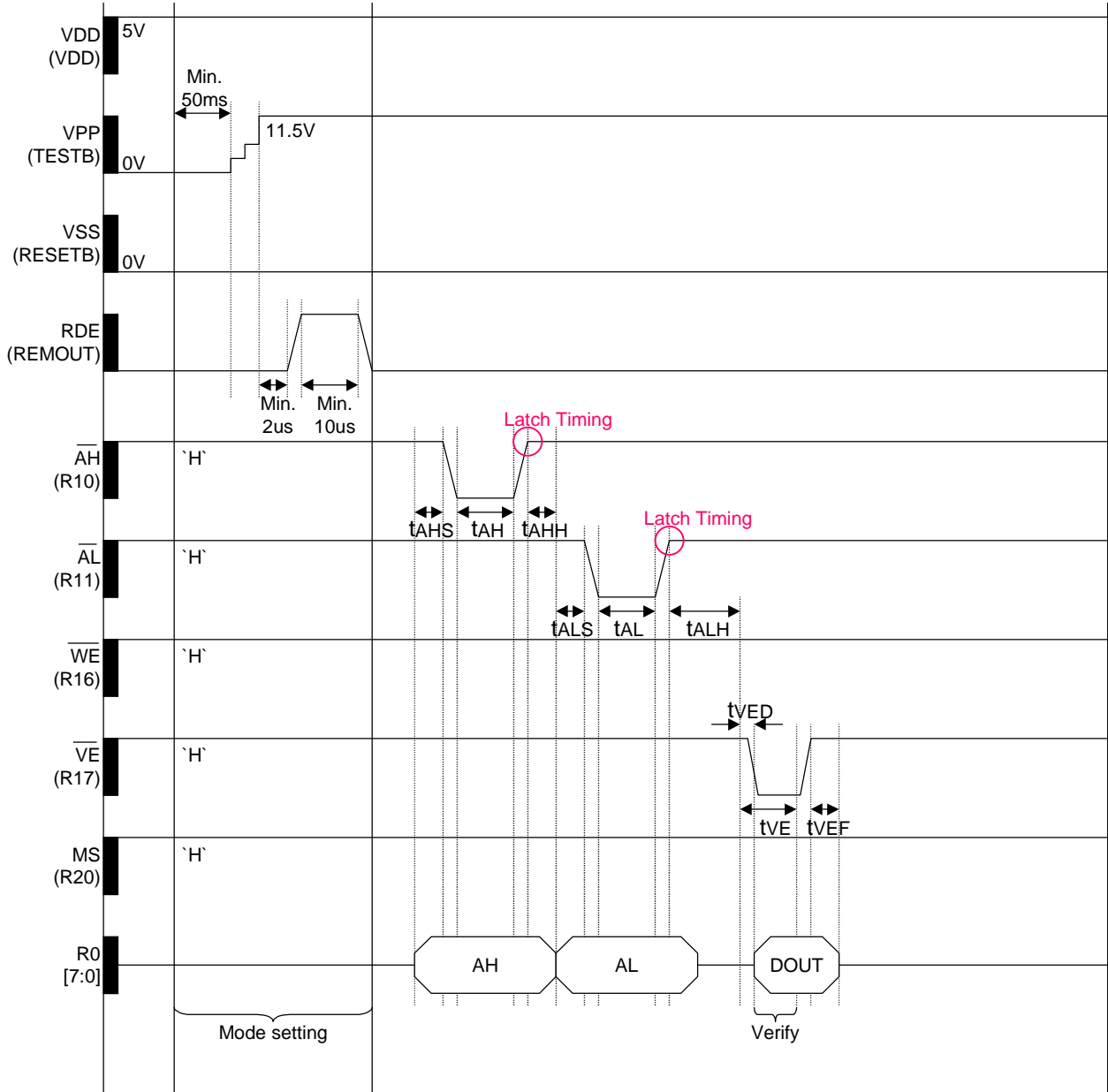

※ AH : High Byte Address Input  
 AL : Low Byte Address Input  
 DIN : Data Input  
 DOUT : Data Output

Lock Bit Write

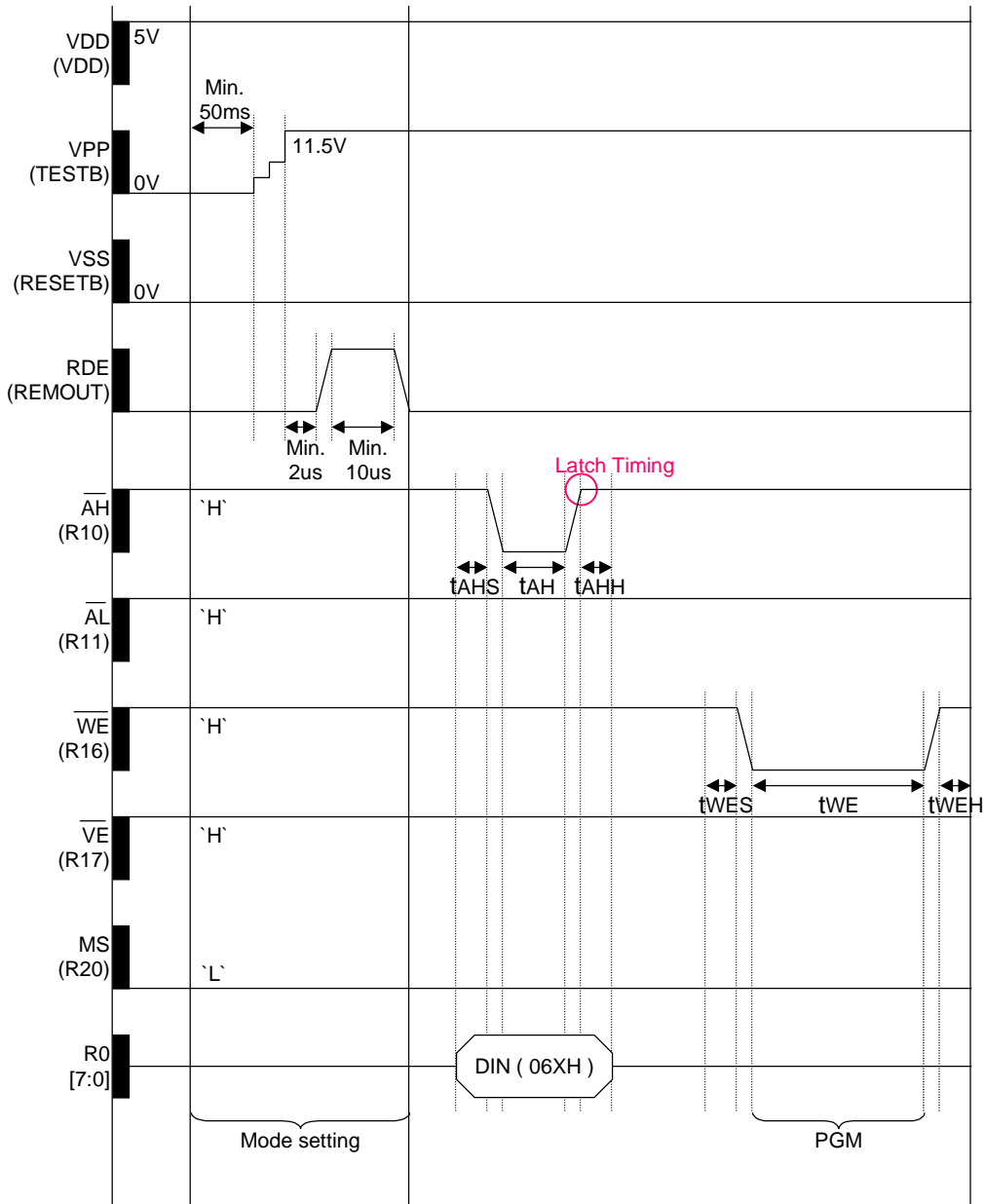

- ※ 1. DIN = 06XH : LOCK bit Write Data. ( X means "don't care" )
- 2. Writing time (R16 is `Low`) is 200us, and can not verify locked or not in this mode. Repeat count is fixed to 20.

LOCK Bit Read

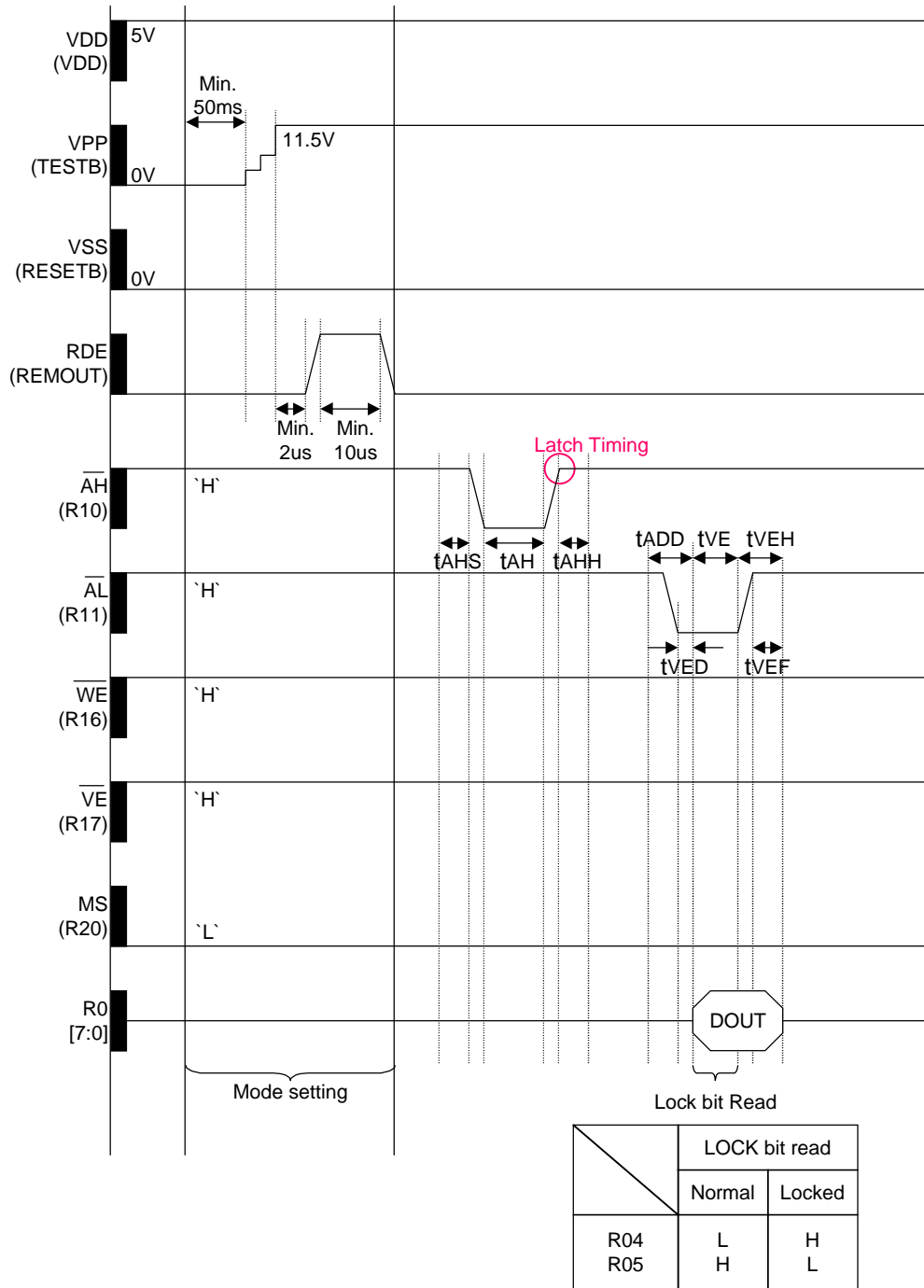

17.7 Programming Flow Chart

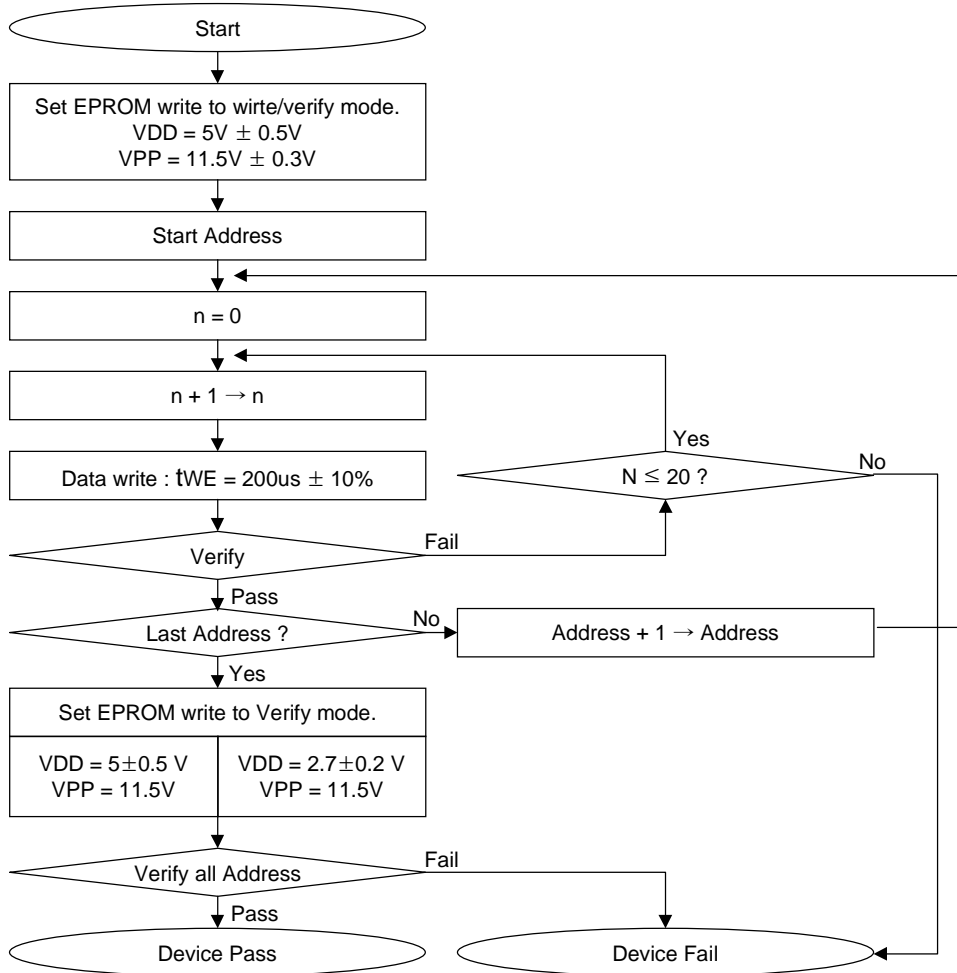

ROM size : 32KB  
 Start address : 0x8000  
 End address : 0xFFFF  
 Blank data : 0x00

### 17.8 REMOUT Port Ioh Characteristics Graph

(typical process & room temperature)

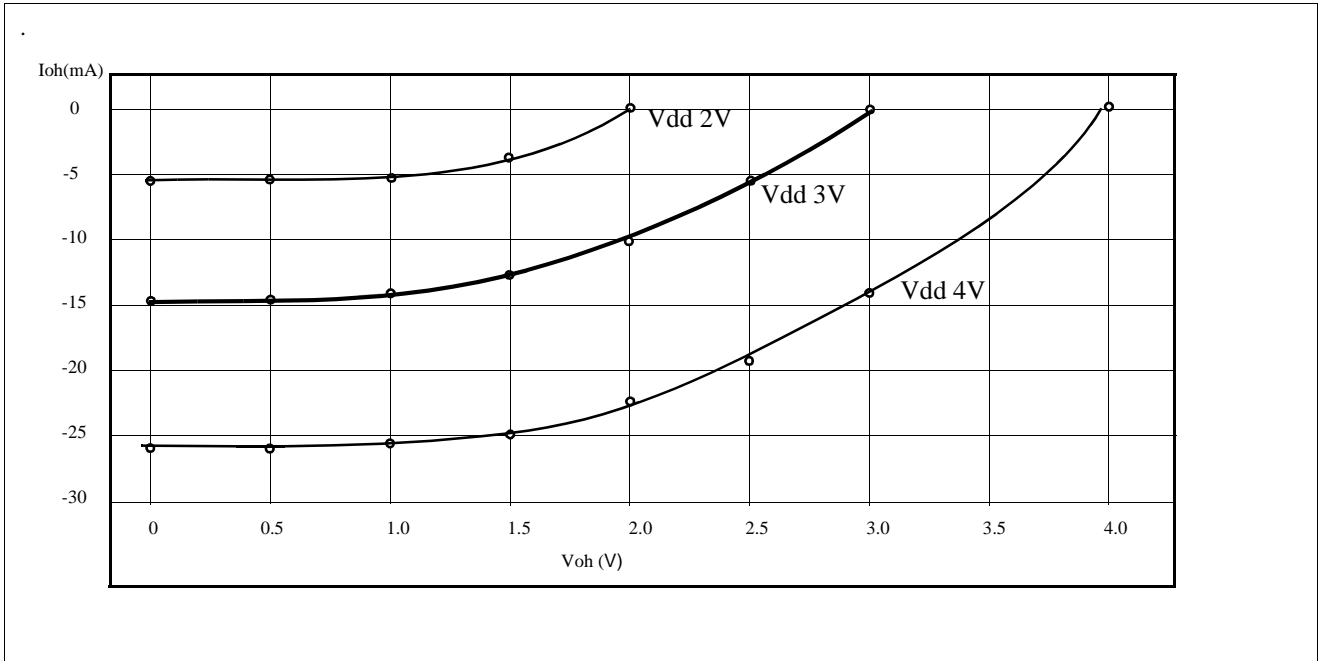

Figure 17-3 Ioh vs Voh

### 17.9 REMOUT Port Iol Characteristics Graph

(typical process & room temperature)

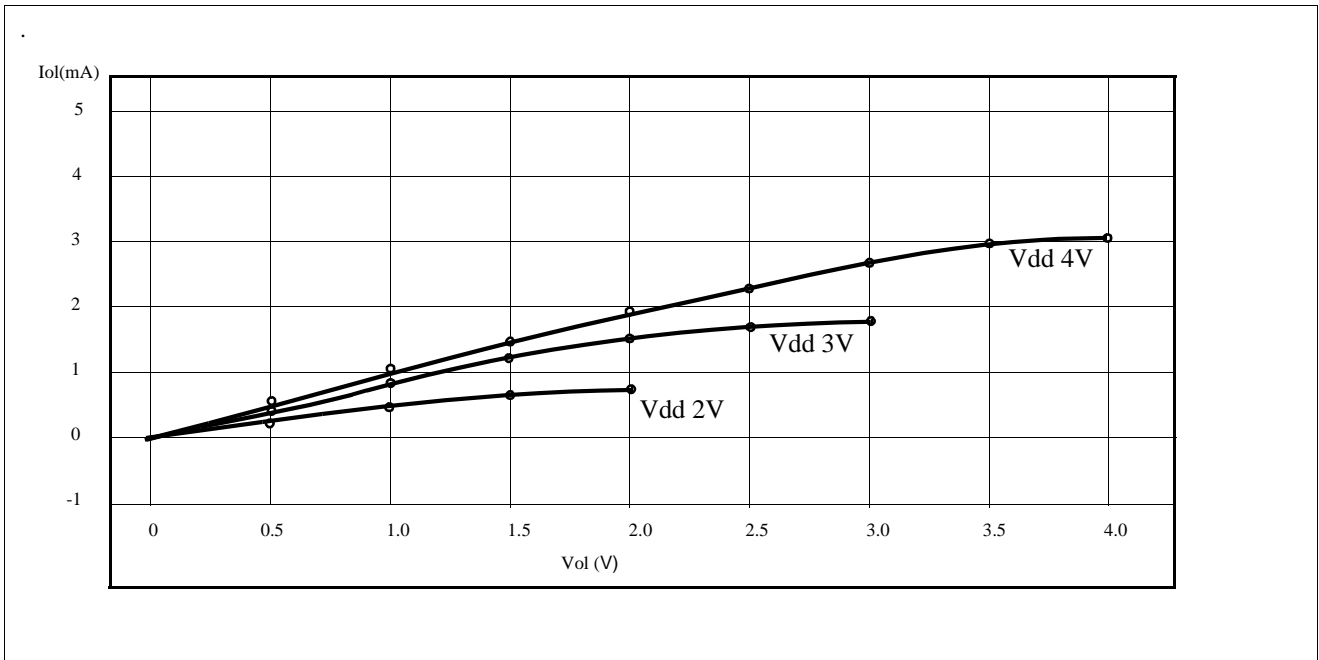

Figure 17-4 Iol vs Vol

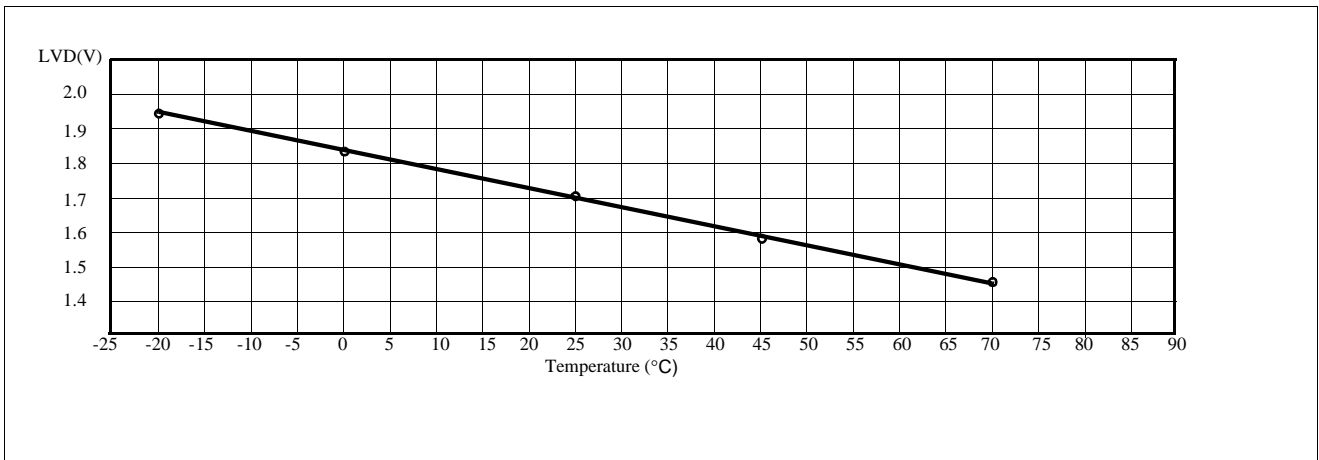
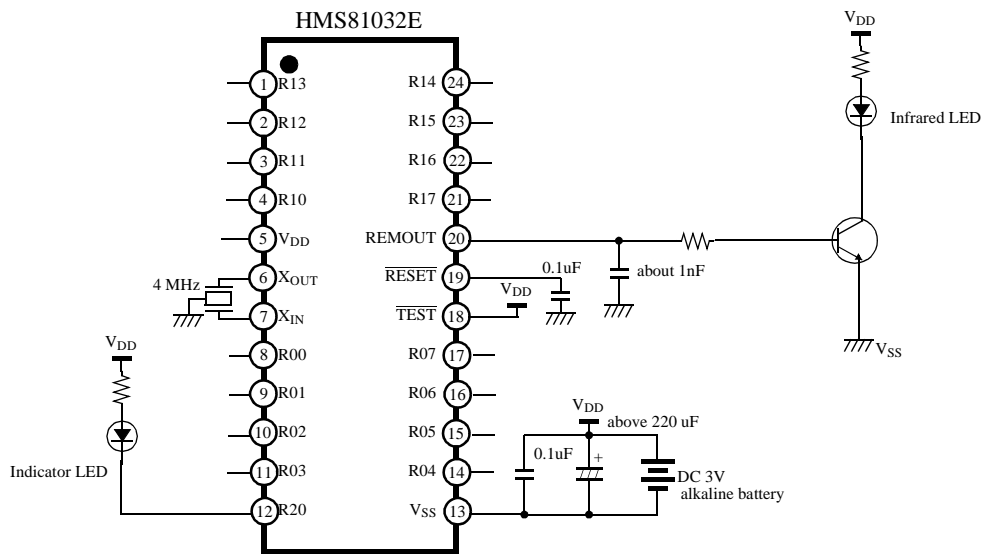

Figure 17-5 Low Voltage vs Temperature

## 18. GENERAL CIRCUIT DIAGRAM

### 18.1 Recommendable circuit diagram of HMS81032E

In case of using high gain Tr. for longer transmission distance application we recommend to attach proper value of capacitor between REMOUT pin of chip and  $V_{SS}$  of the system to prevent excessive overshoot voltage of the system power (over the maximum supply  $V_{DD}$  of chip) during signal transmission.



1. Tr. and IR LED should be located as far as possible from the IC.
2. Power capacitor and noise filtering capacitor should be located as near as possible from the IC.
3. Ceramic resonator should be located as near as possible from the IC.

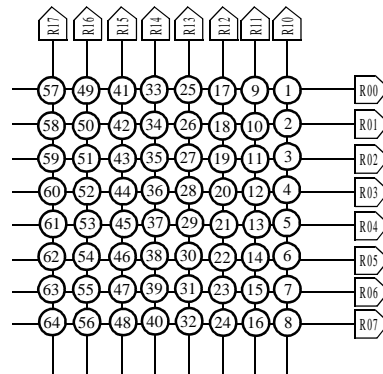
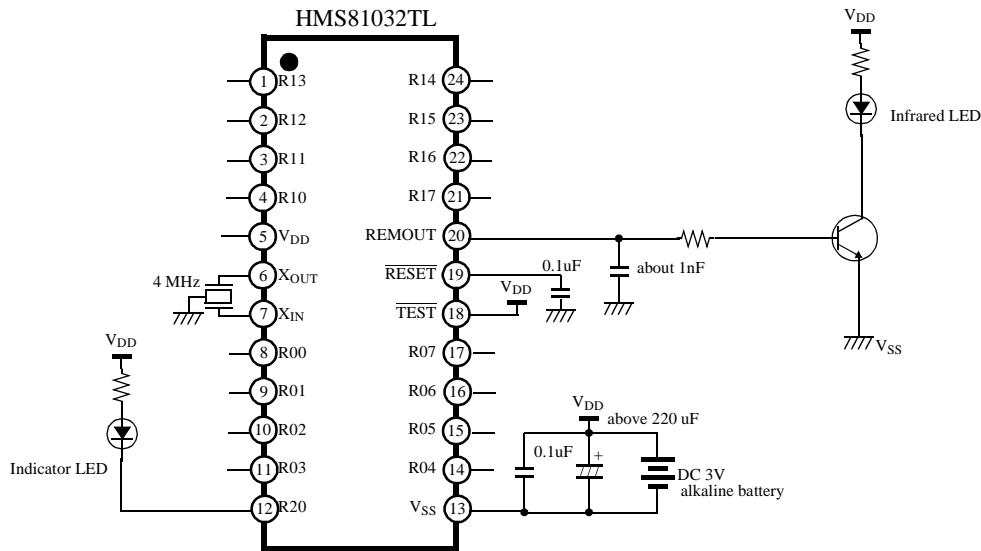

Figure 18-1 GENERAL CIRCUIT DIAGRAM OF HMS81032E

### 18.2 Recommendable circuit diagram of HMS81032TL

In case of using high gain Tr. for longer transmission distance application we recommend to attach proper value of capacitor between REMOUT pin of chip and V<sub>SS</sub> of the system to prevent excessive overshoot voltage of the system power (over the maximum supply V<sub>DD</sub> of chip) during signal transmission.



1. Tr. and IR LED should be located as far as possible from the IC.
2. Power capacitor and noise filtering capacitor should be located as near as possible from the IC.
3. Ceramic resonator should be located as near as possible from the IC.

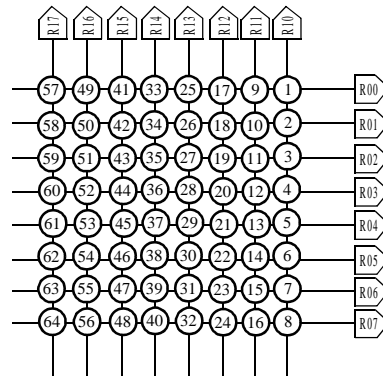

Figure 18-2 GENERAL CIRCUIT DIAGRAM OF HMS81032TL



# APPENDIX

---

**A. MASK ORDER SHEET**

**MASK ORDER & VERIFICATION SHEET**

**HMS810**   **E -UE**

*Customer should write inside thick line box.*

**1. Customer Information**

Company Name	
Application	
Order Date	YYYY MM DD
Tel:	Fax:
Name&Signature:	

**2. Device Information**

Package	<input type="checkbox"/> 20SOP	<input type="checkbox"/> 20PDIP
	<input type="checkbox"/> 24SOP	<input type="checkbox"/> 24SKDIP
	<input type="checkbox"/> 28SOP	<input type="checkbox"/> 28SKDIP
	<input type="checkbox"/> 28PIN DIE	
Mask Data	File Name: ( .OTP)	
Check Sum	( @27c256)	

**3. Inclusion of pull-up resistor in Low Volatage Detection mode**

Port	R00	R01	R02	R03	R04	R05	R06	R07	R10	R11	R12 <sup>*1</sup>	R13	R14 <sup>*1</sup>	R15 <sup>*1</sup>	R16	R17	R20	R21 <sup>*2</sup>	R22 <sup>*2</sup>	R23 <sup>*2</sup>	R24 <sup>*2</sup>	
Y/N																						

\*1 : is not available for 20PIN. So default option is pull-up on.

\*2 : is not available for 20PIN & 24PIN. So default option is pull-up on.

**4. Marking Specification**

*(Please check mark into  )*

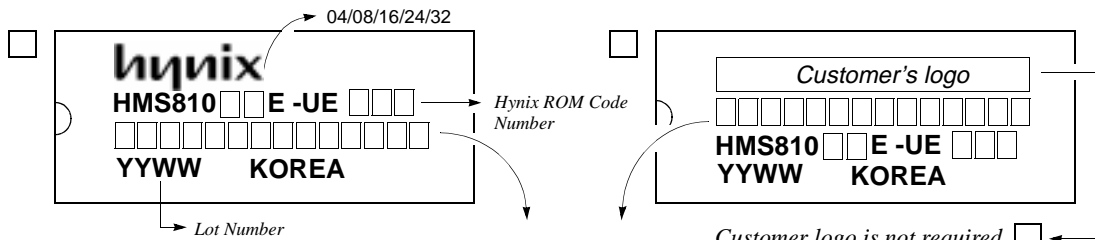

*If the customer logo must be used in the special mark, please submit a clean original of the logo.*

Customer's part number

**5. Delivery Schedule**

	Date	Quantity	Hynix Confirmation
Customer Sample	YYYY MM DD	pcs	
Risk Order	YYYY MM DD	pcs	

**6. ROM Code Verification**

*This box is written after "6.Verification".*

Verification Date:	YYYY MM DD
<i>Please confirm our verification data.</i>	
Check Sum:	
Tel:	Fax:
Name & Signature:	

Approval Date:	YYYY MM DD
<i>I agree with your verification data and confirm you to make mask set.</i>	
Tel:	Fax:
Name & Signature:	



## B. INSTRUCTION

### B.1 Terminology List

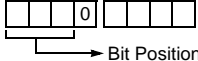
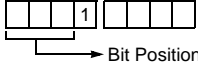
Terminology	Description
A	Accumulator
X	X - register
Y	Y - register
PSW	Program Status Word
#imm	8-bit Immediate data
dp	Direct Page Offset Address
!abs	Absolute Address
[ ]	Indirect expression
{ }	Register Indirect expression
{ }+	Register Indirect expression, after that, Register auto-increment
.bit	Bit Position
A.bit	Bit Position of Accumulator
dp.bit	Bit Position of Direct Page Memory
M.bit	Bit Position of Memory Data (000 <sub>H</sub> ~0FFF <sub>H</sub> )
rel	Relative Addressing Data
upage	U-page (0FF00 <sub>H</sub> ~0FFFF <sub>H</sub> ) Offset Address
n	Table CALL Number (0~15)
+	Addition
x	 Upper Nibble Expression in Opcode
y	 Upper Nibble Expression in Opcode
-	Subtraction
×	Multiplication
/	Division
( )	Contents Expression
^	AND
∨	OR
⊕	Exclusive OR
~	NOT
←	Assignment / Transfer / Shift Left
→	Shift Right
↔	Exchange
=	Equal
≠	Not Equal



**B.2 Instruction Map**

LOW HIGH	0000 00	00001 01	00010 02	00011 03	00100 04	00101 05	00110 06	00111 07	01000 08	01001 09	01010 0A	01011 0B	01100 0C	01101 0D	01110 0E	01111 0F
000	-	SET1 dp.bit	BBS A.bit,rel	BBS dp.bit,rel	ADC #imm	ADC dp	ADC dp+X	ADC !abs	ASL A	ASL dp	TCALL 0	SETA1 .bit	BIT dp	POP A	PUSH A	BRK
001	CLRC				SBC #imm	SBC dp	SBC dp+X	SBC !abs	ROL A	ROL dp	TCALL 2	CLRA1 .bit	COM dp	POP X	PUSH X	BRA rel
010	CLRG				CMP #imm	CMP dp	CMP dp+X	CMP !abs	LSR A	LSR dp	TCALL 4	NOT1 M.bit	TST dp	POP Y	PUSH Y	PCALL Upage
011	DI				OR #imm	OR dp	OR dp+X	OR !abs	ROR A	ROR dp	TCALL 6	OR1 OR1B	CMPX dp	POP PSW	PUSH PSW	RET
100	CLRV				AND #imm	AND dp	AND dp+X	AND !abs	INC A	INC dp	TCALL 8	AND1 AND1B	CMPY dp	CBNE dp+X	TXSP	INC X
101	SETC				EOR #imm	EOR dp	EOR dp+X	EOR !abs	DEC A	DEC dp	TCALL 10	EOR1 EOR1B	DBNE dp	XMA dp+X	TSPX	DEC X
110	SETG				LDA #imm	LDA dp	LDA dp+X	LDA !abs	TXA	LDY dp	TCALL 12	LDC LDCB	LDX dp	LDX dp+Y	XCN	DAS
111	EI				LDM dp,#imm	STA dp	STA dp+X	STA !abs	TAX	STY dp	TCALL 14	STC M.bit	STX dp	STX dp+Y	XAX	STOP

LOW HIGH	10000 10	10001 11	10010 12	10011 13	10100 14	10101 15	10110 16	10111 17	11000 18	11001 19	11010 1A	11011 1B	11100 1C	11101 1D	11110 1E	11111 1F
000	BPL rel	CLR1 dp.bit	BBC A.bit,rel	BBC dp.bit,rel	ADC {X}	ADC !abs+Y	ADC [dp+X]	ADC [dp]+Y	ASL !abs	ASL dp+X	TCALL 1	JMP !abs	BIT !abs	ADDW dp	LDX #imm	JMP [!abs]
001	BVC rel				SBC {X}	SBC !abs+Y	SBC [dp+X]	SBC [dp]+Y	ROL !abs	ROL dp+X	TCALL 3	CALL !abs	TEST !abs	SUBW dp	LDY #imm	JMP [dp]
010	BCC rel				CMP {X}	CMP !abs+Y	CMP [dp+X]	CMP [dp]+Y	LSR !abs	LSR dp+X	TCALL 5	MUL	TCLR1 !abs	CMPW dp	CMPX #imm	CALL [dp]
011	BNE rel				OR {X}	OR !abs+Y	OR [dp+X]	OR [dp]+Y	ROR !abs	ROR dp+X	TCALL 7	DBNE Y	CMPX !abs	LDYA dp	CMPY #imm	RETI
100	BMI rel				AND {X}	AND !abs+Y	AND [dp+X]	AND [dp]+Y	INC !abs	INC dp+X	TCALL 9	DIV	CMPY !abs	INCW dp	INC Y	TAY
101	BVS rel				EOR {X}	EOR !abs+Y	EOR [dp+X]	EOR [dp]+Y	DEC !abs	DEC dp+X	TCALL 11	XMA {X}	XMA dp	DECW dp	DEC Y	TYA
110	BCS rel				LDA {X}	LDA !abs+Y	LDA [dp+X]	LDA [dp]+Y	LDY !abs	LDY dp+X	TCALL 13	LDA {X}+	LDX !abs	STYA dp	XAY	DAA
111	BEQ rel				STA {X}	STA !abs+Y	STA [dp+X]	STA [dp]+Y	STY !abs	STY dp+X	TCALL 15	STA {X}+	STX !abs	CBNE dp	XYX	NOP

**B.3 Instruction Set**
**Arithmetic / Logic Operation**

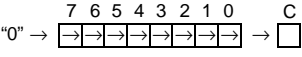
No.	Mnemonic	Op Code	Byte No	Cycle No	Operation	Flag NVGBHIZC
1	ADC #imm	04	2	2	Add with carry.	NVGBHIZC
2	ADC dp	05	2	3	$A \leftarrow (A) + (M) + C$	NV--H-ZC
3	ADC dp + X	06	2	4		
4	ADC !abs	07	3	4		
5	ADC !abs + Y	15	3	5		
6	ADC [ dp + X ]	16	2	6		
7	ADC [ dp ] + Y	17	2	6		
8	ADC { X }	14	1	3		
9	AND #imm	84	2	2		
10	AND dp	85	2	3		
11	AND dp + X	86	2	4		
12	AND !abs	87	3	4		
13	AND !abs + Y	95	3	5		
14	AND [ dp + X ]	96	2	6		
15	AND [ dp ] + Y	97	2	6		
16	AND { X }	94	1	3		
17	ASL A	08	1	2	Arithmetic shift left C    7 6 5 4 3 2 1 0 □ ← ←←←←←←← ← "0"	N-----ZC
18	ASL dp	09	2	4		
19	ASL dp + X	19	2	5		
20	ASL !abs	18	3	5		
21	CMP #imm	44	2	2	Compare accumulator contents with memory contents $(A) - (M)$	N-----ZC
22	CMP dp	45	2	3		
23	CMP dp + X	46	2	4		
24	CMP !abs	47	3	4		
25	CMP !abs + Y	55	3	5		
26	CMP [ dp + X ]	56	2	6		
27	CMP [ dp ] + Y	57	2	6		
28	CMP { X }	54	1	3		
29	CMPX #imm	5E	2	2	Compare X contents with memory contents $(X) - (M)$	N-----ZC
30	CMPX dp	6C	2	3		
31	CMPX !abs	7C	3	4		
32	CMPY #imm	7E	2	2	Compare Y contents with memory contents $(Y) - (M)$	N-----ZC
33	CMPY dp	8C	2	3		
34	CMPY !abs	9C	3	4		
35	COM dp	2C	2	4	1'S Complement : $(dp) \leftarrow \sim(dp)$	N-----Z-
36	DAA	DF	1	3	Decimal adjust for addition	N-----ZC
37	DAS	CF	1	3	Decimal adjust for subtraction	N-----ZC
38	DEC A	A8	1	2	Decrement $M \leftarrow (M) - 1$	N-----Z-
39	DEC dp	A9	2	4		N-----Z-
40	DEC dp + X	B9	2	5		N-----Z-
41	DEC !abs	B8	3	5		N-----Z-
42	DEC X	AF	1	2		N-----Z-
43	DEC Y	BE	1	2		N-----Z-

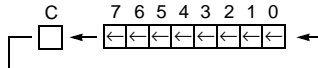
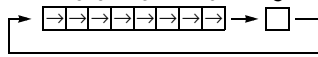
No.	Mnemonic	Op Code	Byte No	Cycle No	Operation	Flag NVGBHIZC
44	DIV	9B	1	12	Divide : YA / X Q: A, R: Y	NV--H-Z-
45	EOR #imm	A4	2	2	Exclusive OR $A \leftarrow (A) \oplus (M)$	N-----Z-
46	EOR dp	A5	2	3		
47	EOR dp + X	A6	2	4		
48	EOR !abs	A7	3	4		
49	EOR !abs + Y	B5	3	5		
50	EOR [ dp + X ]	B6	2	6		
51	EOR [ dp ] + Y	B7	2	6		
52	EOR { X }	B4	1	3		
53	INC A	88	1	2	Increment $M \leftarrow (M) + 1$	N-----ZC
54	INC dp	89	2	4		N-----Z-
55	INC dp + X	99	2	5		N-----Z-
56	INC !abs	98	3	5		N-----Z-
57	INC X	8F	1	2		N-----Z-
58	INC Y	9E	1	2		N-----Z-
59	LSR A	48	1	2	Logical shift right "0" $\rightarrow$  $\rightarrow$ 	N-----ZC
60	LSR dp	49	2	4		
61	LSR dp + X	59	2	5		
62	LSR !abs	58	3	5		
63	MUL	5B	1	9	Multiply : $YA \leftarrow Y \times A$	N-----Z-
64	OR #imm	64	2	2	Logical OR $A \leftarrow (A) \vee (M)$	N-----Z-
65	OR dp	65	2	3		
66	OR dp + X	66	2	4		
67	OR !abs	67	3	4		
68	OR !abs + Y	75	3	5		
69	OR [ dp + X ]	76	2	6		
70	OR [ dp ] + Y	77	2	6		
71	OR { X }	74	1	3		
72	ROL A	28	1	2	Rotate left through Carry 	N-----ZC
73	ROL dp	29	2	4		
74	ROL dp + X	39	2	5		
75	ROL !abs	38	3	5		
76	ROR A	68	1	2	Rotate right through Carry 	N-----ZC
77	ROR dp	69	2	4		
78	ROR dp + X	79	2	5		
79	ROR !abs	78	3	5		
80	SBC #imm	24	2	2	Subtract with Carry $A \leftarrow (A) - (M) - \sim(C)$	NV--HZC
81	SBC dp	25	2	3		
82	SBC dp + X	26	2	4		
83	SBC !abs	27	3	4		
84	SBC !abs + Y	35	3	5		
85	SBC [ dp + X ]	36	2	6		
86	SBC [ dp ] + Y	37	2	6		
87	SBC { X }	34	1	3		
88	TST dp	4C	2	3	Test memory contents for negative or zero, ( dp ) - 00 <sub>H</sub>	N-----Z-
89	XCN	CE	1	5	Exchange nibbles within the accumulator $A_7 \sim A_4 \leftrightarrow A_3 \sim A_0$	N-----Z-

**Register / Memory Operation**

No.	Mnemonic	Op Code	Byte No	Cycle No	Operation	Flag NVGBHIZC
1	LDA #imm	C4	2	2	Load accumulator	N-----Z-
2	LDA dp	C5	2	3	$A \leftarrow (M)$	
3	LDA dp + X	C6	2	4		
4	LDA !abs	C7	3	4		
5	LDA !abs + Y	D5	3	5		
6	LDA [ dp + X ]	D6	2	6		
7	LDA [ dp ] + Y	D7	2	6		
8	LDA { X }	D4	1	3		
9	LDA { X }+	DB	1	4	X- register auto-increment : $A \leftarrow (M)$ , $X \leftarrow X + 1$	
10	LDM dp,#imm	E4	3	5	Load memory with immediate data : $(M) \leftarrow \text{imm}$	-----
11	LDX #imm	1E	2	2	Load X-register	N-----Z-
12	LDX dp	CC	2	3	$X \leftarrow (M)$	
13	LDX dp + Y	CD	2	4		
14	LDX !abs	DC	3	4		
15	LDY #imm	3E	2	2	Load Y-register	N-----Z-
16	LDY dp	C9	2	3	$Y \leftarrow (M)$	
17	LDY dp + X	D9	2	4		
18	LDY !abs	D8	3	4		
19	STA dp	E5	2	4	Store accumulator contents in memory	-----
20	STA dp + X	E6	2	5	$(M) \leftarrow A$	
21	STA !abs	E7	3	5		
22	STA !abs + Y	F5	3	6		
23	STA [ dp + X ]	F6	2	7		
24	STA [ dp ] + Y	F7	2	7		
25	STA { X }	F4	1	4		
26	STA { X }+	FB	1	4	X- register auto-increment : $(M) \leftarrow A$ , $X \leftarrow X + 1$	
27	STX dp	EC	2	4	Store X-register contents in memory	
28	STX dp + Y	ED	2	5	$(M) \leftarrow X$	
29	STX !abs	FC	3	5		
30	STY dp	E9	2	4	Store Y-register contents in memory	-----
31	STY dp + X	F9	2	5	$(M) \leftarrow Y$	
32	STY !abs	F8	3	5		
33	TAX	E8	1	2	Transfer accumulator contents to X-register : $X \leftarrow A$	N-----Z-
34	TAY	9F	1	2	Transfer accumulator contents to Y-register : $Y \leftarrow A$	N-----Z-
35	TSPX	AE	1	2	Transfer stack-pointer contents to X-register : $X \leftarrow \text{sp}$	N-----Z-
36	TXA	C8	1	2	Transfer X-register contents to accumulator: $A \leftarrow X$	N-----Z-
37	TXSP	8E	1	2	Transfer X-register contents to stack-pointer: $\text{sp} \leftarrow X$	N-----Z-
38	TYA	BF	1	2	Transfer Y-register contents to accumulator: $A \leftarrow Y$	N-----Z-
39	XAX	EE	1	4	Exchange X-register contents with accumulator : $X \leftrightarrow A$	-----
40	XAY	DE	1	4	Exchange Y-register contents with accumulator : $Y \leftrightarrow A$	-----
41	XMA dp	BC	2	5	Exchange memory contents with accumulator	N-----Z-
42	XMA dp+X	AD	2	6	$(M) \leftrightarrow A$	
43	XMA {X}	BB	1	5		
44	XYX	FE	1	4	Exchange X-register contents with Y-register : $X \leftrightarrow Y$	-----

**16-BIT operation**

No.	Mnemonic	Op Code	Byte No	Cycle No	Operation	Flag NVGBHIZC
1	ADDW dp	1D	2	5	16-Bits add without Carry $YA \leftarrow (YA) (dp+1) (dp)$	NV--H-ZC
2	CMPW dp	5D	2	4	Compare YA contents with memory pair contents : $(YA) - (dp+1)(dp)$	N-----ZC
3	DECW dp	BD	2	6	Decrement memory pair $(dp+1)(dp) \leftarrow (dp+1)(dp) - 1$	N-----Z-
4	INCW dp	9D	2	6	Increment memory pair $(dp+1)(dp) \leftarrow (dp+1)(dp) + 1$	N-----Z-
5	LDYA dp	7D	2	5	Load YA $YA \leftarrow (dp+1)(dp)$	N-----Z-
6	STYA dp	DD	2	5	Store YA $(dp+1)(dp) \leftarrow YA$	-----
7	SUBW dp	3D	2	5	16-Bits subtract without carry $YA \leftarrow (YA) - (dp+1)(dp)$	NV--H-ZC

**Bit Manipulation**

No.	Mnemonic	Op Code	Byte No	Cycle No	Operation	Flag NVGBHIZC
1	AND1 M.bit	8B	3	4	Bit AND C-flag : $C \leftarrow (C) \wedge (M.bit)$	-----C
2	AND1B M.bit	8B	3	4	Bit AND C-flag and NOT : $C \leftarrow (C) \wedge \sim(M.bit)$	-----C
3	BIT dp	0C	2	4	Bit test A with memory :	MM----Z-
4	BIT !abs	1C	3	5	$Z \leftarrow (A) \wedge (M), N \leftarrow (M_7), V \leftarrow (M_6)$	
5	CLR1 dp.bit	y1	2	4	Clear bit : $(M.bit) \leftarrow "0"$	-----
6	CLRA1 A.bit	2B	2	2	Clear A bit : $(A.bit) \leftarrow "0"$	-----
7	CLRC	20	1	2	Clear C-flag : $C \leftarrow "0"$	-----0
8	CLRG	40	1	2	Clear G-flag : $G \leftarrow "0"$	--0-----
9	CLRV	80	1	2	Clear V-flag : $V \leftarrow "0"$	-0--0---
10	EOR1 M.bit	AB	3	5	Bit exclusive-OR C-flag : $C \leftarrow (C) \oplus (M.bit)$	-----C
11	EOR1B M.bit	AB	3	5	Bit exclusive-OR C-flag and NOT : $C \leftarrow (C) \oplus \sim(M.bit)$	-----C
12	LDC M.bit	CB	3	4	Load C-flag : $C \leftarrow (M.bit)$	-----C
13	LDCB M.bit	CB	3	4	Load C-flag with NOT : $C \leftarrow \sim(M.bit)$	-----C
14	NOT1 M.bit	4B	3	5	Bit complement : $(M.bit) \leftarrow \sim(M.bit)$	-----
15	OR1 M.bit	6B	3	5	Bit OR C-flag : $C \leftarrow (C) \vee (M.bit)$	-----C
16	OR1B M.bit	6B	3	5	Bit OR C-flag and NOT : $C \leftarrow (C) \vee \sim(M.bit)$	-----C
17	SET1 dp.bit	x1	2	4	Set bit : $(M.bit) \leftarrow "1"$	-----
18	SETA1 A.bit	0B	2	2	Set A bit : $(A.bit) \leftarrow "1"$	-----
19	SETC	A0	1	2	Set C-flag : $C \leftarrow "1"$	-----1
20	SETG	C0	1	2	Set G-flag : $G \leftarrow "1"$	--1-----
21	STC M.bit	EB	3	6	Store C-flag : $(M.bit) \leftarrow C$	-----
22	TCLR1 !abs	5C	3	6	Test and clear bits with A : $A - (M), (M) \leftarrow (M) \wedge \sim(A)$	N-----Z-
23	TSET1 !abs	3C	3	6	Test and set bits with A : $A - (M), (M) \leftarrow (M) \vee (A)$	N-----Z-

**Branch / Jump Operation**

No.	Mnemonic	Op Code	Byte No	Cycle No	Operation	Flag NVGBHIZC
1	BBC A.bit,rel	y2	2	4/6	Branch if bit clear :	-----
2	BBC dp.bit,rel	y3	3	5/7	if ( bit ) = 0 , then $pc \leftarrow ( pc ) + rel$	
3	BBS A.bit,rel	x2	2	4/6	Branch if bit set :	-----
4	BBS dp.bit,rel	x3	3	5/7	if ( bit ) = 1 , then $pc \leftarrow ( pc ) + rel$	
5	BCC rel	50	2	2/4	Branch if carry bit clear if ( C ) = 0 , then $pc \leftarrow ( pc ) + rel$	-----
6	BCS rel	D0	2	2/4	Branch if carry bit set if ( C ) = 1 , then $pc \leftarrow ( pc ) + rel$	-----
7	BEQ rel	F0	2	2/4	Branch if equal if ( Z ) = 1 , then $pc \leftarrow ( pc ) + rel$	-----
8	BMI rel	90	2	2/4	Branch if minus if ( N ) = 1 , then $pc \leftarrow ( pc ) + rel$	-----
9	BNE rel	70	2	2/4	Branch if not equal if ( Z ) = 0 , then $pc \leftarrow ( pc ) + rel$	-----
10	BPL rel	10	2	2/4	Branch if plus if ( N ) = 0 , then $pc \leftarrow ( pc ) + rel$	-----
11	BRA rel	2F	2	4	Branch always $pc \leftarrow ( pc ) + rel$	-----
12	BVC rel	30	2	2/4	Branch if overflow bit clear if ( V ) = 0 , then $pc \leftarrow ( pc ) + rel$	-----
13	BVS rel	B0	2	2/4	Branch if overflow bit set if ( V ) = 1 , then $pc \leftarrow ( pc ) + rel$	-----
14	CALL !abs	3B	3	8	Subroutine call	
15	CALL [dp]	5F	2	8	$M(sp) \leftarrow ( pc_H )$ , $sp \leftarrow sp - 1$ , $M(sp) \leftarrow ( pc_L )$ , $sp \leftarrow sp - 1$ , if !abs, $pc \leftarrow abs$ ; if [dp], $pc_L \leftarrow ( dp )$ , $pc_H \leftarrow ( dp+1 )$ .	-----
16	CBNE dp,rel	FD	3	5/7	Compare and branch if not equal :	-----
17	CBNE dp+X,rel	8D	3	6/8	if ( A ) $\neq$ ( M ) , then $pc \leftarrow ( pc ) + rel$ .	
18	DBNE dp,rel	AC	3	5/7	Decrement and branch if not equal :	-----
19	DBNE Y,rel	7B	2	4/6	if ( M ) $\neq$ 0 , then $pc \leftarrow ( pc ) + rel$ .	
20	JMP !abs	1B	3	3	Unconditional jump	
21	JMP [!abs]	1F	3	5	$pc \leftarrow$ jump address	-----
22	JMP [dp]	3F	2	4		
23	PCALL upage	4F	2	6	U-page call $M(sp) \leftarrow ( pc_H )$ , $sp \leftarrow sp - 1$ , $M(sp) \leftarrow ( pc_L )$ , $sp \leftarrow sp - 1$ , $pc_L \leftarrow ( upage )$ , $pc_H \leftarrow "OFFH"$ .	-----
24	TCALL n	nA	1	8	Table call : $( sp ) \leftarrow ( pc_H )$ , $sp \leftarrow sp - 1$ , $M(sp) \leftarrow ( pc_L )$ , $sp \leftarrow sp - 1$ , $pc_L \leftarrow ( Table\ vector\ L )$ , $pc_H \leftarrow ( Table\ vector\ H )$	-----

## Control Operation &amp; Etc.

No.	Mnemonic	Op Code	Byte No	Cycle No	Operation	Flag NVGBHIZC
1	BRK	0F	1	8	Software interrupt : $B \leftarrow "1"$ , $M(sp) \leftarrow (pc_H)$ , $sp \leftarrow sp-1$ , $M(s) \leftarrow (pc_L)$ , $sp \leftarrow sp - 1$ , $M(sp) \leftarrow (PSW)$ , $sp \leftarrow sp - 1$ , $pc_L \leftarrow ( 0FFDE_H )$ , $pc_H \leftarrow ( 0FFDF_H )$ .	---1-0--
2	DI	60	1	3	Disable all interrupts : $I \leftarrow "0"$	-----0--
3	EI	E0	1	3	Enable all interrupt : $I \leftarrow "1"$	-----1--
4	NOP	FF	1	2	No operation	-----
5	POP A	0D	1	4	$sp \leftarrow sp + 1$ , $A \leftarrow M( sp )$	restored
6	POP X	2D	1	4	$sp \leftarrow sp + 1$ , $X \leftarrow M( sp )$	
7	POP Y	4D	1	4	$sp \leftarrow sp + 1$ , $Y \leftarrow M( sp )$	
8	POP PSW	6D	1	4	$sp \leftarrow sp + 1$ , $PSW \leftarrow M( sp )$	
9	PUSH A	0E	1	4	$M( sp ) \leftarrow A$ , $sp \leftarrow sp - 1$	-----
10	PUSH X	2E	1	4	$M( sp ) \leftarrow X$ , $sp \leftarrow sp - 1$	
11	PUSH Y	4E	1	4	$M( sp ) \leftarrow Y$ , $sp \leftarrow sp - 1$	
12	PUSH PSW	6E	1	4	$M( sp ) \leftarrow PSW$ , $sp \leftarrow sp - 1$	
13	RET	6F	1	5	Return from subroutine $sp \leftarrow sp + 1$ , $pc_L \leftarrow M( sp )$ , $sp \leftarrow sp + 1$ , $pc_H \leftarrow M( sp )$	-----
14	RETI	7F	1	6	Return from interrupt $sp \leftarrow sp + 1$ , $PSW \leftarrow M( sp )$ , $sp \leftarrow sp + 1$ , $pc_L \leftarrow M( sp )$ , $sp \leftarrow sp + 1$ , $pc_H \leftarrow M( sp )$	restored
15	STOP	EF	1	3	Stop mode ( halt CPU, stop oscillator )	-----