



Choosing the Right LCDs For use with F²MC series MCUs

Theory of Operation.....	1
LCD Basics.....	1
Single Back Plane.....	1
Multiple Back Planes	1
Direct Drive and Multiplex drive	2
Bias Types and Duty Ratio	3
Glance of Fujitsu Microcontrollers with LCD Controller/Driver on Chip.....	3
Features.....	3
Details of LCD Controller/ Driver Macro:	3
Controller Section.....	3
RAM for Display.....	4
Driver Section	4
Devices with Voltage Booster	4
Devices without Voltage Booster	6
Description of Operation.....	6
Recommended Bias and Duty Ratio Combinations.....	6
Bias Connections.....	6
Intensity Variations.....	7
Duty Ratio Settings.....	7
Technical Specifications of LCD Display	8
Display types (TN and STN Devices)	8
Addressing (Direct and Multiplex)	8
Based on LCD Color Technology.....	8
Display Lighting.....	8
Viewing Modes	8
Duty Ratio	9
Drive Voltage.....	9
Pin or Electromeric Type	9
Display Temperature Range.....	9
List of Suitable LCDs	10
Applications	10
Implementation	10
Description	10
Interface Block Diagram of MB89P568 with Alphanumeric LCD	10
Specification of Chosen LCD for implementation.....	11
Software	12
Conclusion	12
References	12
Appendix A.....	13
Appendix B.....	14

Choosing the Right LCDs For use with F2MC Series MCUs

Introduction

It is often necessary for microcontroller-based design to display status information to the user. If the quantity of the information is small, light emitting diodes (LEDs) can give a simple status display. However, LEDs are not practical if the volume of the information gets too large. Segmented LED displays allow more information to be displayed but, LEDs consume power, shortening the life of the battery-operated devices. Liquid Crystal Displays (LCDs) are small, light and low power alternatives. Due to this advantage LCDs are becoming very popular devices in such kind of applications.

Many device series of Fujitsu F2MC series of Microcontrollers are having on chip LCD controller that can drive segmented display. This application describes the features, drive and bias types, of such microcontrollers. A project file in C language, provided along with this application note is based on F2MC-MB89560 series. It gives a very good idea for initializing different registers for using particular drive method. The code is for displaying a scrolling message and Real time clock.

Theory of Operation

Before discussing features, capabilities and LCDs required to be chosen, it is important to know about the basic theory of operation of LCDs.

LCD Basics

A liquid crystal display is manufactured by layering polarizing liquid crystal between two plates of glass and a polarizer. This is shown in Figure 1. When the voltage potential is developed across the liquid crystal, the crystalline matrix gets twisted. The effect is that the voltage controls a polarizing filter, alternately blocking and transmitting light.

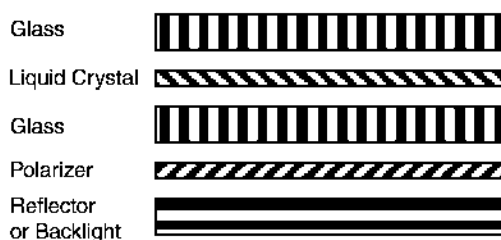

Figure 1. LCD Cross Section

Applying the control voltage for too long a period of time causes the matrix of the liquid crystal to permanently twist, ruining the polarizing effect. To prevent this problem, the LCD must be pulsed—first in one direction and then in the other. For this reason the segment must always be driven using AC. The shifting effect is neutralized. The voltage is alternated quickly enough (typically 50–100 Hz) that the eye does not perceive the ON segment as flickering.

Single Back Plane

Traditional LCD displays were built with one back plane of glass acting as a common conductor for all the segments. Another glass plate had a conductor for each segment brought out to the edge of the panel for connection to the outside. The signals to drive this type of display are illustrated in Figure 2.

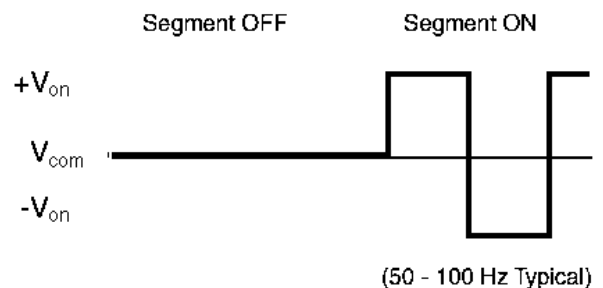

Figure 2. LCD Drive Signal

As the number of segments to be driven increase, the number of pins required on the driver chip increase proportionately.

Multiple Back Planes

In order to reduce the number of control lines required, for large segment counts, modern LCD display panels are usually built with more than one back plane. This is done by splitting back plane glass in to several conductors and connecting more than one segment to each control pin.

Then by placing a signal on the common pins as well as the segment pins, the segment pins can be toggled independently. It is shown in Figure 3 along with LCD drive signal.

Choosing the Right LCDs For use with F2MC Series MCUs

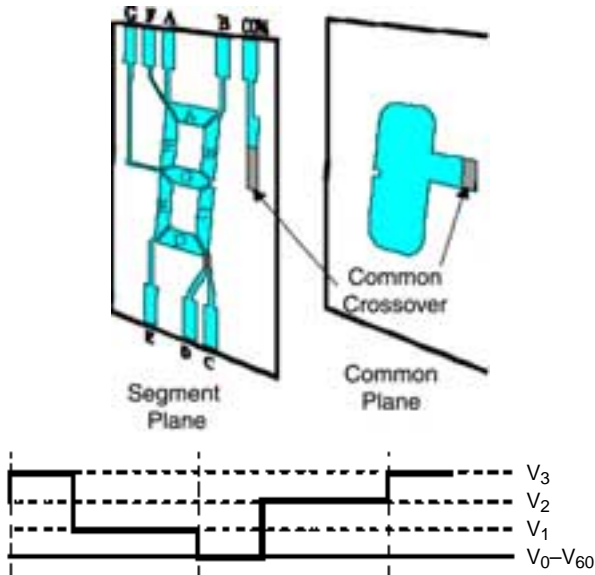

Figure 3.

Direct Drive and Multiplex drive

Two types of drive method are used for matrix displays. In the static or direct drive method, each pixel is individually wired to a driver. This is a simple driving method, but, as the number of pixels is increased, the wiring becomes very complex. Single back plane displays explained in earlier sections could drive only direct/static type of displays. An alternative method is the multiplex drive method, in which the pixels are arranged and wired in a matrix format.

When **direct driving** a liquid crystal display, each individual segment has an individual lead which comes to the edge of the display to a unique pin. Maximum contrast and viewing angle can be attained by direct driving a display. As the number of display segments increase, direct drive may become impractical due to the number of drive circuits and external interconnections required. Both can be reduced by means of time-multiplexing the display.

In static driving method, the AC frequency used to drive each segment is identical. This AC frequency is called the frame frequency. The static driving method uses the frame frequency (1/TF) of several tens to several hundreds Hz. **Frame Frequency** determines the degree of flickering and vividness. Lower frame frequencies can cause visible flicker. Higher frame frequencies do not provide sufficient time for charging the capacitive LCD elements.

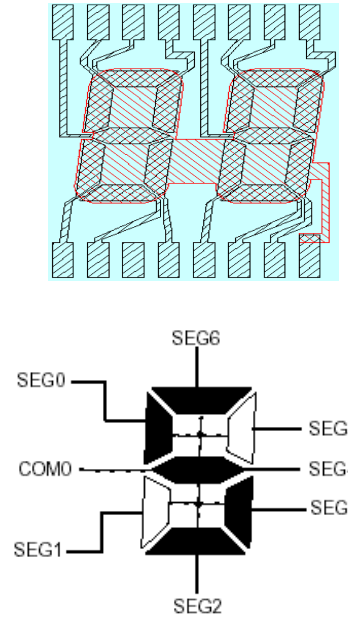

Figure 4.

When **multiplexing** an LCD, appropriate segments are connected together to form groups, which are sequentially addressed by means of multiple back plane (sometimes called common plane) electrodes. These groups are organized in a matrix of rows and columns. Typical multiplex drivers generate amplitude varying, time synchronized waveforms, and apply them to the row and column lines of the matrix at a high rate.

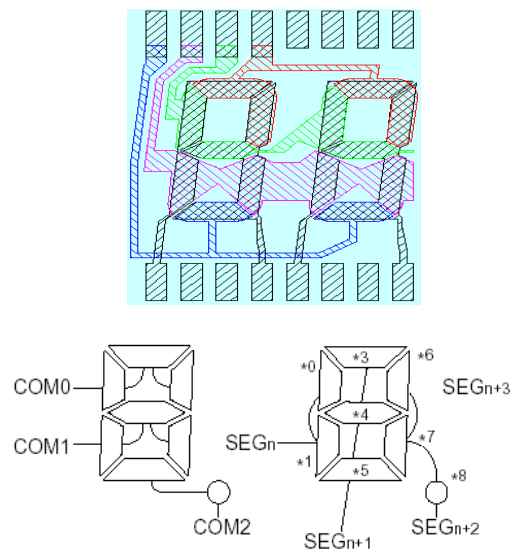

Figure 5.

Fujitsu Microcontrollers with on chip LCD controllers are capable of driving both **Direct** and **Multiplex drive** type of LCD displays with single and multiple back planes.

In the multiplex (MUX) driving method, there are a wide variety of drive waveforms and bias levels depending on the driver manufacturers. The MUX level depends on the number of back planes (also called common lines or rows). For example, a triple display (1/3 MUX) has three back planes. Dot matrix displays have typically eight or sixteen back planes for optimal performance. TN LCD's begin to lose contrast fast after the display exceeds 16 back planes. Graphic displays using STN LCD's have up to 480 back planes. MUX driving method is effective in reducing the number of driver circuits, the number of connections between the circuit and the display cell, and the cost when driving many display picture elements

Segment is one of the bars that make up a single character in a LCD display. Usually 7 segments for numeric and 14 segments for alpha/numeric digits.

Bias Types and Duty Ratio

Bias is the number of voltage levels used to power the LCD display. Duty ratio or Duty cycle indicates the number of segments driven by each individual output driver. Table 1 is a general example that shows Duty ratio and bias voltage. The applicable bias types and duty ratio of Fujitsu Microcontrollers will be explained in the following sections.

Glance of Fujitsu Microcontrollers with LCD Controller/Driver on Chip

Table 5 in Appendix A lists out the F²MC series MCUs having LCD controller/driver with complete features. More than 30 device series in F²MC-8L and a few series in F²MC-16LX are having LCD controller/driver with various configuration of common, segments, LCD RAM, booster etc.

Features

The important features of Fujitsu microcontroller are listed below.

- Suitable for low cost applications
- Capable of driving Static (also called direct drive) and multiplex type of LCD displays
- Large LCD RAM
- Built in Booster
- Internal dividing resistors and optional external resistor
- A choice of two driving clock sources: Main clock and sub clock
- Choice of 3-duty cycle: 1/2, 1/3, 1/4
- Some segment ports serve as open drain output only ports and some serve as general purpose IO ports

Details of LCD Controller/ Driver Macro:

Figure 6 is the example block diagram of LCD controller/driver on MB89560 series, having 24 segments and 4 common outputs.

Please refer to hardware manual and data sheet for detailed specifications for the required series of microcontroller.

The LCD controller/ Driver circuit can be divided in to two major sections: the display controller section that generates segment and common signals according to display data and memory data and a driver section that can drive the LCD directly.

Controller Section

Controller section consists of LCD control registers and display RAM.

The control registers mainly for configuration of frame cycle, enable/disable operation in watch mode, control of LCD drive supply voltage, selecting display blanking, non blanking and also for display mode. For details of register settings refer to the hardware manual.

Table 1:

Display Duty Ratio	Static	1/2	1/3	1/4	1/7	1/8	1/11	1/12	1/14	1/16	1/24	1/32	1/64
Drive Bias	–	1/2	1/3	1/3	1/4	1/4	1/5	1/5	1/5	1/5	1/5	1/5	11/5
Voltage Levels	2	3	4	4	5	5	5	6	6	6	6	6	6

Choosing the Right LCDs For use with F2MC Series MCUs

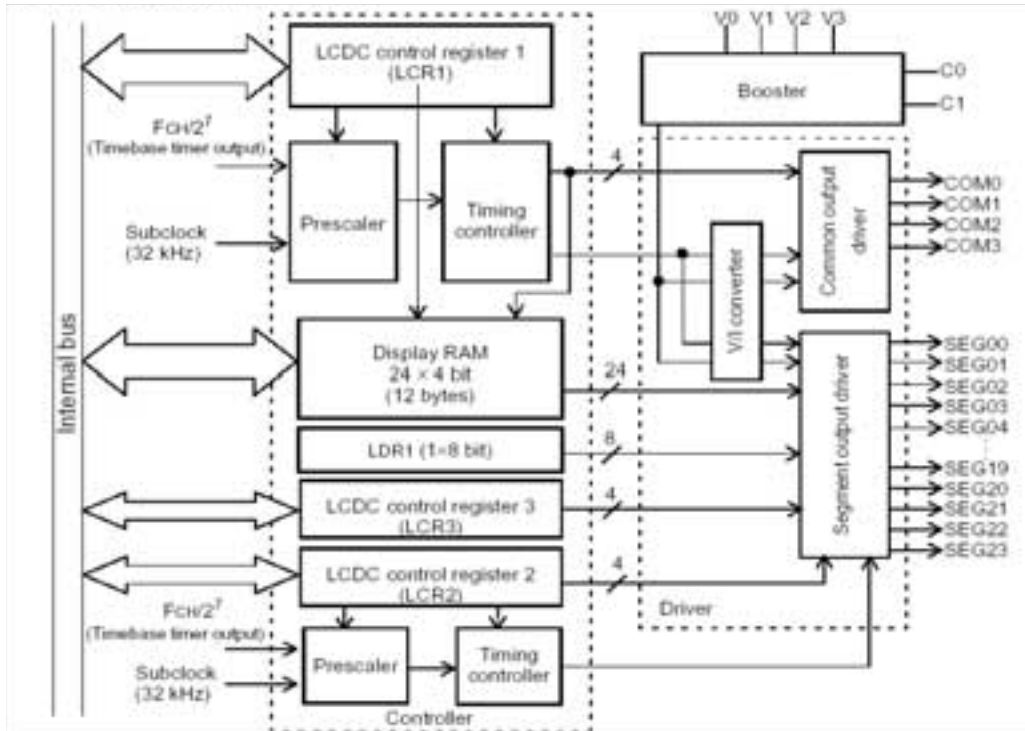

Figure 6. Block Diagram of LCD Controller/Driver

RAM for Display

LCD controller has RAM of varying sizes depending on particular series and its segment/common drive capability. Data in this RAM is automatically output from the segment output pins in synchronization with the timing of selecting common signals.

Figure 7 is the example for 24 segment signals corresponding 12 locations of display RAM. Bits 0 and 4 at each location are synchronized with the COM0 selecting timing; bit 1 and 5 bits with COM1 selecting timing; bit 2 and 6 with the COM2 selecting timing; bit 3 and 7 with the COM3 selecting timing. If the value of each bit is 1, the signal is converted into select voltage. If the value is 0, the signal is converted into non-select voltage. At reset, the common pins SEG8 to SEG23 serve as general-purpose IO ports. COM0 and COM1, SEG0 and SEG7 go low, resulting in no LCD display. Always byte access should be made to this RAM.

Read, write operations from and to display RAM are possible at any timing, since this operation is performed independently of the CPU.

When SEG7 to SEG23 serve as general-purpose ports, the eight upper bytes can be used for ordinary RAM.

Driver Section

Driver section shown in Figure 6 uses 4 common output pins (COM0 to COM3), 24 segment output pin (SG0 to SEG23) and 2 external capacitor pins (C0 and C1), add 4 LCD driving power supply pins (V0 to V3) and V/I converter.

In devices that have internal voltage boosters, the pins Co and C1 are used to connect the voltage booster capacitors and V0 to V3 pins are used to connect external capacitors. In devices without boosters, they are the LCD driving power supply pins. The V/I converter circuit generates alternating current waveforms from the voltage signals it receives from the timing controller to drive the LCD. This is essential as explained above in LCD Basics section.

Devices with Voltage Booster

Most of the Fujitsu microcontrollers that have sub clock provision have LCD controller/driver along with built in voltage boosters.

The LCD driver supply voltage is generated by the internal voltage booster, which boosts a reference voltage supplied via the V1 pin or by an internal reference voltage generator of 1.5V. The devices with voltage booster do not have on chip divider resistor, in which case V0 to V3 C0, C1 pins are all used to connect external capacitors.

Figure 8 explains the details of voltage booster.

Application Note

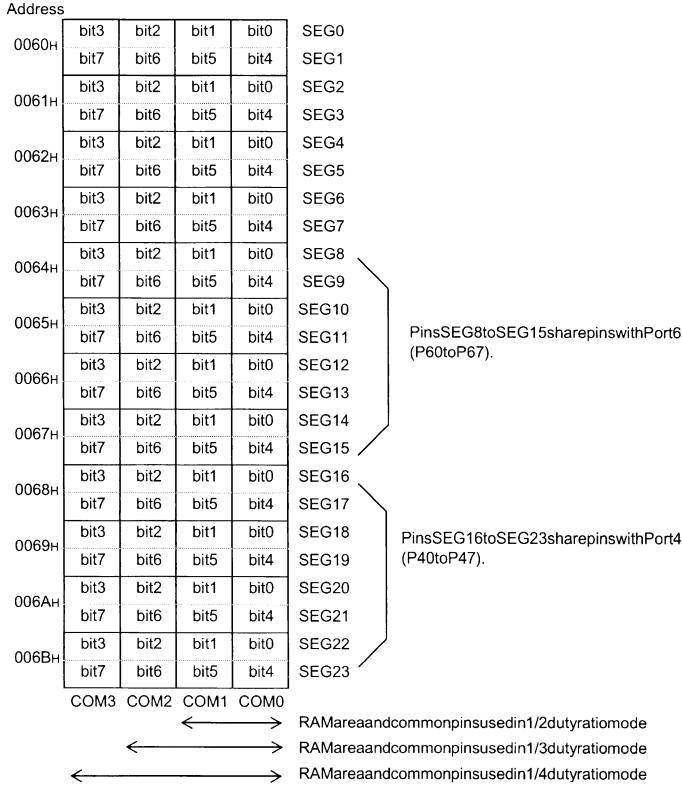
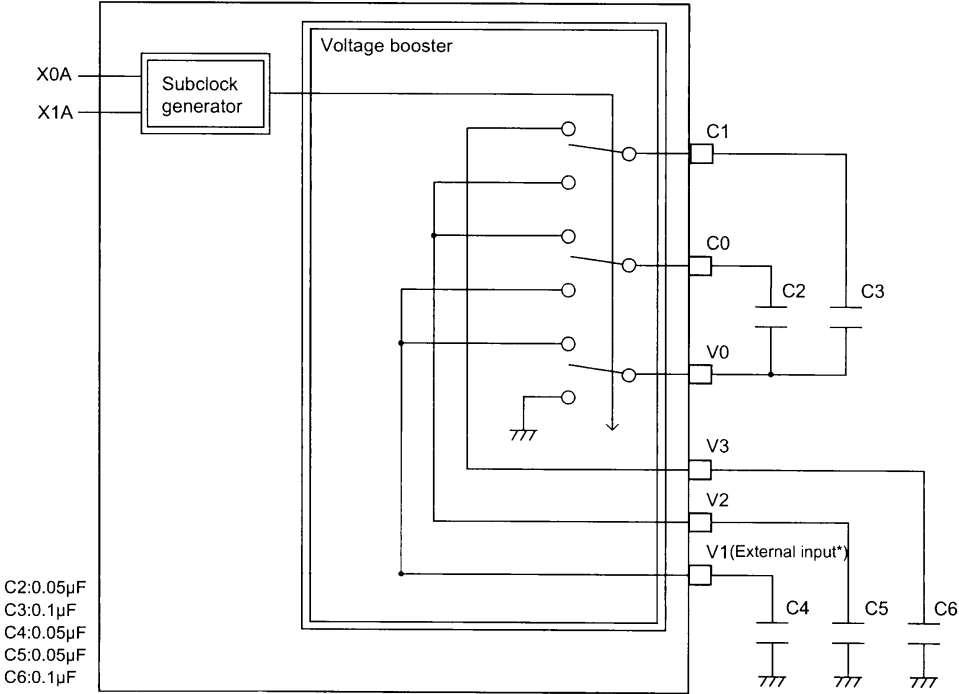

Figure 7.



* When the drive supply voltage control bit of the LCD control register is set to "1" (LCR1: VSEL = 1), the internal reference voltage generator circuit is disconnected. An external reference voltage supply can then be connected to the V1 pin. When this is done, capacitor C4 is not required.

Figure 8.

Choosing the Right LCDs For use with F2MC Series MCUs

From a 32.768KHz sub clock and the reference voltage, the internal voltage booster generates a voltage equal to 2-3 times the reference voltage. This booster doesn't work in modes in which sub clock is stopped (during sub-stop mode etc). Similarly it cannot be used where single clock option is selected.

Reference voltage generator outputs a constant 1.5V regardless of variations in the operating voltage. Even the external voltage reference option connected to V1 pin also can be used. But when using external voltage reference, care should be taken to disconnect the internal reference voltage generator from the booster. This can be done by bit set/rest in LCD control register.

Devices without Voltage Booster

Devices that do not have internal voltage boosters have internal voltage divider resistors. There is an option for connecting external divider resistors at pins V0 to V3.

Description of Operation

- Write data to be displayed to display RAM
- Configure the LCD controller registers corresponding to the chosen specifications of LCD display panel.
- Output the driving waveform of the LCD panel according to data in display RAM.

To do this, main clock or sub clock must be selected. Clock selection may also be switched between main or sub clock. This switching may cause flicker in display. So the display can be

blanked once to switch between the clock sources. The display driving is a 2-frame Ac waveform. Suitable Bias and duty cycle should be selected.

Recommended Bias and Duty Ratio Combinations

Table 2 gives the bias and duty ratio settings for all Fujitsu Microcontrollers with LCDcontroller/driver.

Table 2:

Device Type	Bias	1/2 Duty Ratio	1/3 Duty Ratio	1/4 Duty Ratio
Without internal voltage booster	1/2 Bias	Yes	No	No
	1/3 Bias	No	Yes	Yes
With Internal voltage booster	1/2 Bias	No	No	No
	1/3 Bias	No	Yes	Yes

From Table 2 it can be noticed that, for the devices with the voltage booster, 1/2 bias configuration is not possible to use. This configuration requires an external divider resistor to be enabled and drive voltage pins connected together. This will be explained in the following sections.

Bias Connections

Bias configuration using internal resistors is done by proper bit settings of LCD control register. Refer hardware manual for detailed register settings. Figure 9 explains the bias configuration using external voltage resistors.

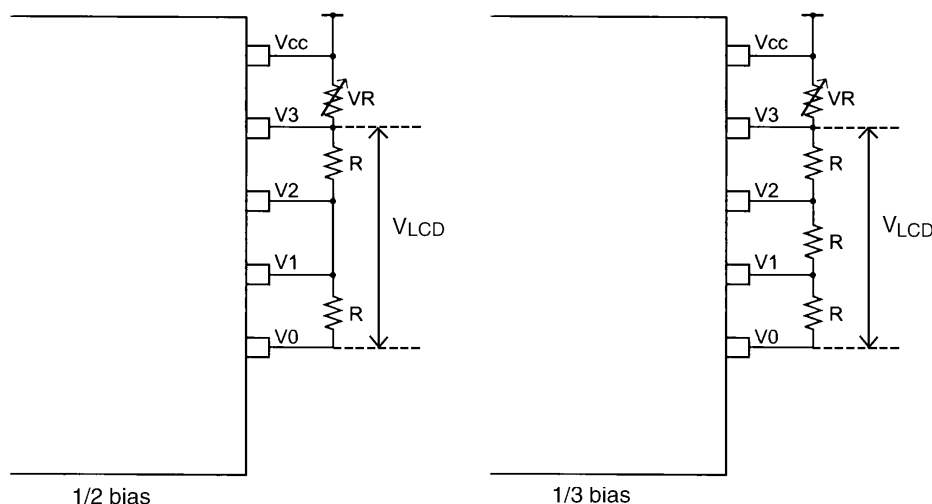
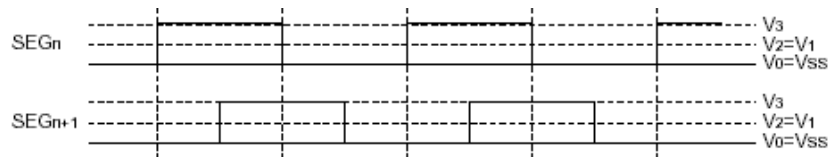

Figure 9.

Application Note

1/2 Bias: To configure 1/2 bias mode when using external voltage divider resistors, connect V1 and V2 pins together and no resistors between them. This divides the voltage between V1 and V0, V2 and V0 equally as $1/2 V_{LCD}$ where V_{LCD} is the LCD operating voltage. LCD operating voltage depends on the chosen LCD display panel.

	V3	V2	V1	V0
1/2 Bias	V_{LCD}	$1/2 V_{LCD}$	$1/2 V_{LCD}$	GND



1/3 Bias: To configure 1/3 bias mode, three equal resistors should be connected between the LCD drive supply pins when using external resistors divider. The value of these resistors 'R' depends on the LCD drive operating voltage (V_{LCD}) and the chosen LCD display panel.

	V3	V2	V1	V0
1/3 Bias	V_{LCD}	$1/2 V_{LCD}$	$1/2 V_{LCD}$	GND

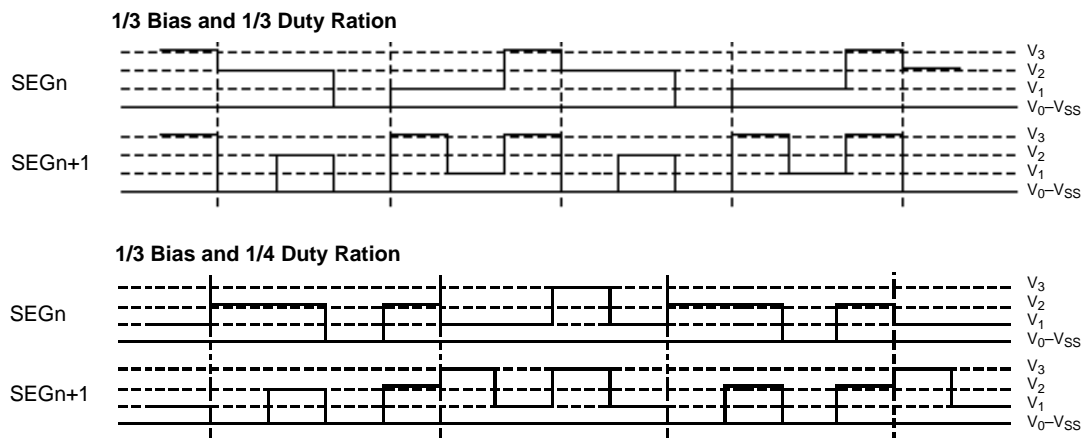

Intensity Variations

When the internal resistors do not provide sufficient LCD display brightness, varying external resistor can be connected between V3 and VCC pins.

Duty Ratio Settings

The display drive output is a multiplex drive-type two-frame A.C waveform. Table 3 gives the details of common outputs used, display data bit used and duty ratio settings.

Table 3:

Duty Ratio Setting	Common Outputs Used	Display Data Bit Used							
		bit 7	bit 6	bit 5	bit 4	bit 3	bit 2	bit 1	bit 0
1/2	COM0 to COM 1 (2 pins)	—	—	○	○	—	—	○	○
1/3*	COM0 to COM 2 (3 pins)	—	○	○	○	—	○	○	○
1/4*	COM0 to COM 3 (4 pins)	○	○	○	○	○	○	○	○

○: Used —: Not Used

*: The LCD common output option must be selected for pins COM2 and COM3.

Depending on the duty ratio used, the interface connection to the chosen LCD display panel varies.

Choosing the Right LCDs For use with F2MC Series MCUs

Technical Specifications of LCD Display

Having known all the above aspects such as the LCD basics of operation and LCD controller/driver macro features, it is easy to choose the required LCD display panels suitable for the applications. Following are the detailed guidelines that help us in this direction.

Display types (TN and STN Devices)

The most common LCD that is used for everyday items like watches and calculators is called the *twisted nematic* (TN) display. This device consists of a nematic liquid crystal sandwiched between two plates of glass. This configuration sets up a 90° twist into the bulk of the liquid crystal, hence the name of the display.

For this reason, the TN device is impractical for large information displays with conventional addressing schemes. This problem was solved in the mid 1980's with the invention of the super-twisted nematic (STN) display. In this device, the director rotates through an angle of 270°, compared with the 90° for the TN cell.

- Fujitsu Microcontrollers with LCDC could be interfaced with TN displays.

Addressing (Direct and Multiplex)

Addressing is the process by which pixels are turned on and off in order to create an image. There are two main types of addressing, direct and multiplexing. Direct addressing is convenient for displays where there are only a few elements that have to be activated. With direct addressing, each pixel in the display has its own drive circuit. A microprocessor must individually apply a voltage to each element. A common application of direct addressing is the traditional seven-segment liquid crystal display, found in wristwatches and similar devices.

In multiplex addressing, a larger number of pixels are involved. When the elements are in a regular order, they can be addressed by their row and column instead of each element being driven separately. This reduces the complexity of the circuitry because each pixel no longer needs its own driver circuit. If you have a 10x10 matrix of pixels, with direct addressing, you need 100 individual drivers. However, if you use multiplex addressing, you only need 20 drivers, one for each row and one for each column. This is a tremendous advantage, especially as displays become larger and larger.

- Fujitsu devices have capability of direct and also multiplex addressing.

Based on LCD Color Technology

In Passive Display—all the active electronics (transistors) are outside of the display screen. Passive displays do not provide a wide viewing angle. Monochrome LCD images usually appear as blue or dark gray images on top of a grayish-white background. LCD displays use two basic techniques for producing color. Passive matrix is less expensive of the two technologies. The other technology, called thin film transistor (TFT) or active matrix produces color images that are as sharp as traditional CRT displays, but the technology is expensive. In Active matrix Display—transistors are built into each pixel within the screen. Most LCD displays are backlit to make them easier to read.

- Fujitsu devices are suitable to be interfaced with passive matrix displays.

Display Lighting

In order for a display to show information, it must have a light source. Some displays use only ambient light and employ a reflective surface mounted behind the display—most calculators and watches are like this. These displays are not very bright because the light must pass through multiple polarizers, which severely cut down on the intensity of the light, in addition to the various layers of the display that are only semi-transparent. Therefore a more intense source is employed in the form of a back lighting system. Light bulbs mounted behind and at the edges of the display replace the reflected ambient light. This results in brighter displays for two reasons: the light doesn't have to come in through the display and therefore does not lose part of the intensity, and the lighting system can be made more intense than ambient light. Back lighting has the disadvantage of being very power intensive. Back lighting systems are used in more complex displays such as laptop computer screens.

- For the low power and low cost applications LCDs chosen to be interfaced with Fujitsu microcontrollers most popularly are the one without backlight. However the devices are capable of interfacing with backlight displays also.

Viewing Modes

There are 3 types Reflective, transfective, transmissive having feature of positive/negative type image.

An LCD is basically a reflective part. In the reflective mode, ambient light is used to illuminate the display. This is achieved by

combining a reflector with the rear polarizer. It works best in an outdoor or well-lighted office environment.

Transflective LCDs are a mixture of the reflective and transmissive types, with the rear polarizer having partial reflectivity. They are combined with a backlight for use in all types of lighting conditions. The backlight can be left off where there is sufficient outside lighting, conserving power. In darker environments, the backlight is turned on to provide a bright display. Transflective LCDs will not “wash out” when operated in direct sunlight.

Transmissive LCDs have a transparent rear polarizer and do not reflect ambient light. They require a backlight to be visible. They work best in low light conditions with the backlight on continuously.

Another feature of the viewing mode is whether the LCD is a positive or negative image. The standard image is positive, which means a light background with a dark character or dot. This works best in reflective or transflective mode. A negative image is usually combined with a transmissive mode. This provides a dark background with a light character. A backlight must be used to provide good illumination. In most graphic applications, the transmissive negative mode is inverted. This combination provides a light background with dark characters.

- Fujitsu Microcontrollers are suitable to be used with reflective with positive/negative and transflective with positive/negative modes.

Table 4: LCD Viewing Modes

Viewing Mode	Display Description	Application Comments	Direct Sunlight	Office Light	Subdued Light	Very Low Light
Reflective Positive Image	Dark segments on light background	Not backlit. Provides best head-on contrast and environmental stability	Excellent	Very Good	Average	Poor
Transflective Positive Image	Dark segments on gray background	Can be viewed by reflected ambient light or with backlighting	Excellent (No backlight)	Good (No backlight)	Good (Backlit)	Very Good (Backlit)
Transflective Negative Image	Light gray segments on dark background	Needs high ambient light or backlighting. Frequently used with color and multicolor translector	Good (No backlight)	Fair (No backlight)	Good (Backlit)	Very Good (Backlit)
Transmissive Negative Image	Backlit segments on dark background	Cannot be read by reflection	Poor (Backlit)	Good (Backlit)	Very Good (No backlight)	Excellent (Backlit)
Transmissive Positive Image	Dark segments on backlit background	Designed for very low light conditions, yet able to be read in bright ambient lights	Good (No backlight)	Good (Backlit)	Very Good (Backlit)	Excellent (Backlit)

Duty Ratio

This refers to the multiplex ratio of the column driver. The ratio is between the single column driveline and the number of rows with which it will interface.

- Duty ratio of Fujitsu Microcontrollers is listed in Appendix A

Drive Voltage

There are 2 types of displays Low voltage (LV) drive type and High voltage (HV) type. LV LCD display can function with LCD operating drive voltage of 2.2V to 3.3Volts. HV LCD displays can function with LCD operating drive voltage of 2.2V to 4.5Volts.

- Care should be taken to choose LCD displays required to be interfaced with Microcontrollers.

Pin or Electromeric Type

LCD displays can have pins or a silicone rubber strip made up of sequentially spaced conductive and non-conductive (insulating) material called zebra or electromer.

- Depending on applications and PCB layout required type of LCD could be chosen.

Display Temperature Range

LCDs are available to work in consumer application environment or high temperature environment.

- Depending on the application, corresponding display should be chosen.

Choosing the Right LCDs For use with F2MC Series MCUs

List of Suitable LCDs

Appendix B gives example of suitable LCDs chosen to be used with Fujitsu Microcontrollers. This is just an example reference for choosing LCDs. But various other vendors are also available in the market. Depending on the applications, LCD specifications should be carefully chosen.

Applications

Liquid crystal displays have become a common part of our daily life. They are standard equipment in industrial as well as consumer applications e.g. telecommunication, aviation, pleasure boats, office communication, measurements, control engineering and entertaining electronics. We rarely find two applications using the same kind of LCD technology and even within the same application there are various reasonable alternatives. Considering the comprehensive system definition of a display, driving method and packaging optimum fulfillment of requirements can be reached. This includes the choice between many different display technologies, types of illumination and electronic configuration.

Applications using Fujitsu Microcontrollers with simple low cost segmented and alphanumeric type of displays are listed next.

- Sensors, transducers and detectors
- Digital clocks, watches
- Microwave oven
- CD Player
- Pager, e-mail phone and GSM phone

- As display in Medical instruments like respiratory instrument and blood glucose measurement etc
- Power supply rack monitors
- Handheld shaft alignment equipments and high precision measuring instruments

Implementation

This section mainly describes the hardware and software details when using LCD with Fujitsu microcontroller. The following application is based on MB89560 series interfaced to 14 segment alphanumeric display.

Description

The block below is an example of interface between segmented LCD panel and MB89P568 Microcontroller. One can observe that the interface is very simple and display can be connected directly to microcontroller. The common and segment pins of the displays are connected to corresponding common and segments pin of the device. V1, V2 V3 are for connecting external resistor for forming bias. Fujitsu devices have option for connecting either internal or external resistors, the above example shown uses internal resistor for bias. If the built-in voltage booster is used, then V0 to V3, C0, C1 pins are to be connected to external decoupling capacitors. In the above case the booster is not used. If the intensity due to the internal resistors is not sufficient, external variable resistor could be connected to V3 pin.

Interface Block Diagram of MB89P568 with Alphanumeric LCD

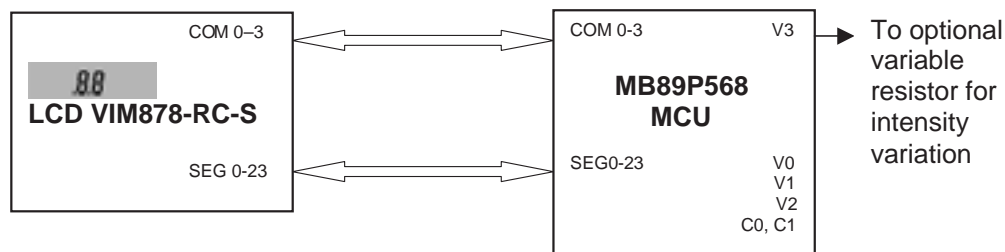

Specification of Chosen LCD for implementation

Standard LCD Model Specifications: Module Model Number Notation is shown below for example.

VIM 808()-DP7.5-RC-S-HV4.5-G-N-12-FM-REMARKS

Notation	Descriptions
VIM	APPLICATION Blank: watch L: Clock C: Calculator I: Instrument G: Graphic DRIVE SCHEME Blank: Static Multiplex
808()	MODEL NUMBER (): Version No. (if any)
DP7.5	CONNECTOR TYPES 1: Pin type (Pin not Supplied) 2: Electrometric (Zebra) type DP: DIL pins + pin length (Blank: 6.35)
RC	POLARIZER GRADE RC: Commercial Reflective FC: Commercial Transflective TC: Commercial Transmissive RH: Reflective, high stability FH: Transflective, high stability TH: Transmissive, high stability NP: No Polarizer SP: Separate Polarizer (non-attached)
S	FLUID S: Standard W: Wide temperature
HV4.5	DRIVE VOLTAGE LV HV See Typical Characteristics of LCD for details.
G	STN MODE G: Green/Yellow S: Silver B: Blue (Negative) Blank: TN
N	MODEL Blank: Positive N: Negative
12	VIEWING DIRECTION Blank: 6 o'clock 12: 12 o'clock 3: 3 o'clock. etc.
FM	FIRST MINIMUM Blank: 2nd minimum

Choosing the Right LCDs For use with F²MC Series MCUs

TYPICAL ELECTRO-OPTICAL CHARACTERISTICS FOR TWIST NEMATIC (TN) DISPLAY : ①

LC Fluid Type ②		TN COMMERCIAL (S)										TN EXTENDED (W)												
Drive Method		Static	Multiplex (LV)					Multiplex (HV)					Static	Multiplex (HV-W)										
			1/2	1/3	1/4	1/8	1/16	1/2	1/3	1/4	1/8	1/16		1/2	1/3	1/4	1/8	1/16						
Operating Temperature		°C	10 ~ +60					0 ~ +50					-10 ~ +60					40 ~ +80		-30 ~ +80			-20 ~ +70	
Storage Temperature		°C	-20 ~ +60										-20 ~ +60					-40 ~ +80						
Operating Voltage ③ ④		-10°C	---	---	---	---	---	---	---	---	---	---	---	---	---	---	---	---	---	6.4	8.5			
		0°C	---	---	---	---	3.5	5.0	---	---	---	---	---	---	---	---	---	---	---	6.2	8.2			
		25°C	3.0	3.0	3.1	3.2	3.4	4.6	3.9	4.2	4.7	5.4	7.5	5.0	3.9	4.2	4.7	5.8	7.7					
		50°C	---	---	---	---	2.4	4.1	---	---	---	---	---	---	---	---	---	---	---	5.3	7.1			
Switching Time ⑤		T _{OFF}	0°C	mSec		250	350		250	300	200		250	300	100	180		250	300					
			25°C	mSec		80	100		100	150	80		130	140	40	55		100	150					
		T _{ON}	0°C	mSec		200	300		250	300	180		250	300	100	110		250	300					
			25°C	mSec		60	100		100	150	80		90	100	50	50		100	150					
Typical Temp Coefficient (0 ~ 40°C)		mV/°C	---	-10		---	---	-7.5		-12.5	-12.5	---	-7.5											
Operating Frequency Range ⑥		Hz	30 ~ 300					30 ~ 85					30 ~ 300					30 ~ 85						
Max. Contrast Ratio		25°C	CR _{MAX}		30	20										30		20						
Viewing Angle @CR≥2 ⑤		25°C	θ _y	-65° ~ +25°		50° ~ +10°	45° ~ +5°	-65° ~ +25°		50° ~ +10°	45° ~ +5°	-65° ~ +25°		-65° ~ +25°			-45° ~ +5°							
			θ _x	-70° ~ +70°					-70° ~ +70°					-70° ~ +70°					-70° ~ +70°					

Notes: ① The following table presents typical values only for positive TN displays and these values are subject to changes without notice. Please consult VARITRONIX for the exact values of your display.

② For fluids with other characteristics, please consult VARITRONIX.

③ Optimum drive voltage of multiplexed display varies with temperature. It must be adjusted for optimum operation in the extremes of temperature range. Please consult VARITRONIX for the temperature coefficient of the particular fluid used.

④ Maximum allowable DC voltage is 50 mV.

⑤ See following figures for definitions of switching time, contrast ratio, inclined viewing angles θ_y & θ_x.

⑥ Display could flicker but consumes less current at lower operating frequency.

Software

The heart of the application is the software. The software project file along with this application note is for MB89560 series. This code is for:

- Displaying scrolling message, scrolling from right to left on 14 segment alphanumeric display.
The code displays the following message
'Welcome to Fujitsu Microelectronics America, Inc'.
- Displaying Real time Clock using device internal watch prescalar in low power mode.

The purpose of this display code is mainly to show how to initialize LCD controller depending on LCD chosen and also to show an example interface with Fujitsu F²MC MB89560 series interface. The software project file can be downloaded from <http://www.fma.fujitsu.com/micro/appnotes.asp>. The modules of source code are flexible to be implemented in similar kind of applications.

Conclusion

This application note gives a good idea for the user in interfacing and also in choosing LCDs that could be interfaced with Fujitsu Microcontrollers with on chip LCDcontroller/driver.

References

Fujitsu Microcontroller Products CD ROM V3.3A.

Appendix A

Table 5: List of F²MC Microcontrollers with LCD Controller/Driver

F ² MC Series	Total Pixels	Segments & Common	LCDRAM	Drive Type	Bias Type & Duty Ratio	Booster	Dividing Resistors	Type of LCDs to be driven	
F²MC-8L									
1	MB89150 Series	128	32 x 4	18 Bytes	Static/Multiplex	Bias: 1/2, 1/3 Duty: 1/2, 1/3, 1/4	Built in	Internal and facility for external	Segment and Alpha Numeric Type
2	MB89160 Series	96	24 x 4	12 Bytes	Static/Multiplex	Bias: 1/2, 1/3 Duty: 1/2, 1/3, 1/4	Built in	Internal and facility for external	Segment and Alpha Numeric Type
3	MB89180 Series	128	32 x 4	18 Bytes	Static/Multiplex	Bias: 1/2, 1/3 Duty: 1/2, 1/3, 1/4	NA	Internal and facility for external	Segment and Alpha Numeric Type
4	MB89480 Series	124	31 x 4	16 Bytes	Static/Multiplex	Bias: 1/2, 1/3 Duty: 1/2, 1/3, 1/4	NA	Internal and facility for external	Segment and Alpha Numeric Type
5	MB89550 Series	128	32 x 4	18 Bytes	Static/Multiplex	Bias: 1/2, 1/3 Duty: 1/2, 1/3, 1/4	Built in		
6	MB89560 Series	96	32 X 4	18 Bytes	Static/Multiplex	Bias: 1/2, 1/3 Duty: 1/2, 1/3, 1/4	Built in	Internal and facility for external	Segment and Alpha Numeric Type
7	MB89800 Series	280	70 X 4	35 Bytes	Static/Multiplex	Bias: 1/2, 1/3 Duty: 1/2, 1/3, 1/4	NA	Internal and facility for external	Segment and Alpha Numeric Type
8	MB89820 Series	200	50 x 4	25 Bytes	Static/Multiplex	Bias: 1/2, 1/3 Duty: 1/2, 1/3, 1/4	NA	Internal and facility for external	Segment and Alpha Numeric Type
9	MB89870 Series	96	24 X 4	12 bytes	Static/Multiplex	Bias: 1/2, 1/3 Duty: 1/2, 1/3, 1/4	NA	Internal and facility for external	Segment and Alpha Numeric Type
F²MC-8L									
10	MB89920 Series	112	28 X 4	14 Bytes	Static/Multiplex	Bias: 1/2, 1/3 Duty: 1/2, 1/3, 1/4	NA	Internal and facility for external	Segment and Alpha Numeric Type
11	MB89940 Series	68	17 x 4	9 Bytes	Static/Multiplex	Bias: 1/2, 1/3 Duty: 1/2, 1/3, 1/4	NA	Internal and facility for external	Segment and Alpha Numeric Type
12	MB89950 Series	168	42 x 4	21 Bytes	Static/Multiplex	Bias: 1/2, 1/3 Duty: 1/2, 1/3, 1/4	NA	Internal and facility for external	Segment and Alpha Numeric Type
13	MB89980 Series	56	14 X 4	7 Bytes	Static/Multiplex	Bias: 1/2, 1/3 Duty: 1/2, 1/3, 1/4	NA	Internal and facility for external	Segmented and Alpha Numeric Type
14	MB89650 Series	128	32 x 4	18 Bytes	Static/Multiplex	Bias: 1/2, 1/3 Duty: 1/2, 1/3, 1/4	Built in	Internal and facility for external	Segmented and Alpha Numeric Type
F²MC-16LX									
1	MB90520 Series	128	32 x 4	18 Bytes	Static/Multiplex	Bias: 1/2, 1/3 Duty: 1/2, 1/3, 1/4	NA	Internal and facility for external	Segmented and Alpha Numeric Type
2	MB90420 Series	128	24 x 4	12 Bytes	Static/Multiplex	Bias: 1/2, 1/3 Duty: 1/2, 1/3, 1/4	NA	Internal and facility for external	Segmented and Alpha Numeric Type
3	MB90425 Series	96	24 x 4	12 Bytes	Static/Multiplex	Bias: 1/2, 1/3 Duty: 1/2, 1/3, 1/4	NA	Internal and facility for external	Segmented and Alpha Numeric Type
F²MC-16L									
1	MB90620 Series	128	32 x 4	18 Bytes	Static/Multiplex	Bias: 1/2, 1/3 Duty: 1/2, 1/3, 1/4	NA	Internal and facility for external	Segmented and Alpha Numeric Type

Choosing the Right LCDs For use with F2MC Series MCUs

Appendix B

Table 6: Example List of LCDs that could be used along with Fujitsu Microcontrollers with on chip LCD Controller Driver

LCD Types	Manufacturer	Contact Information
Seven Segment and Alphanumeric and Custom glass LCD displays	Varitronix	www.varitronix.com
	Display Tech Ltd	www.displaytech-us.com
	Densitron Technologies	www.densitron.com
	LXD Inc	www.lxdinc.com
	Trident Displays	www.tridentdisplays.co.uk
	Purdy Electronics Corporation	www.purdyelectronics.com
	LCD systems	www.lcdsystems.com

FUJITSU MICROELECTRONICS AMERICA, INC.

Corporate Headquarters

1250 East Arques Avenue, Sunnyvale, California 94088-3470

Tel: (408) 922-9100 Fax: (408) 737-5999

Email: inquiry@fma.fujitsu.com Web site: <http://www.fma.fujitsu.com>

© 2002 Fujitsu Microelectronics America, Inc.
All rights reserved. All company and product
names are trademarks or registered
trademarks of their respective owners.

EC-AN-20949-10/2002